

Comprehensive  
Catalogue

2007



**Susol**  
*Super Solution*

**Air Circuit Breakers**

**LS** Industrial Systems  
[www.lsis.biz](http://www.lsis.biz)

Susol Air Circuit Breakers



# *Susol* ACB

*LS Industrial Systems Made It!*



## Super Solution

# Contents :

---

<b>Overview</b>	4
<b>External configuration</b>	14
<b>Internal configuration</b>	16
<b>Ordering</b>	18
<b>Ratings</b>	22
<b>Trip relays</b>	26
<b>Accessories</b>	50
<b>Electrical diagram</b>	78
<b>Dimensions</b>	80
<b>Technical information</b>	
• Insulation voltage	102
• Temperature derating	103
• Operating conditions	104
• Protective coordination	105
<b>Standards &amp; Approval</b>	111
<b>Ordering sheet</b>	112

---

## Susol ACB

Premium Susol ACB meets your demands for high breaking capacity, fully line-up, and optimized panel size.

Various accessories and connection methods realize user-friendly handling.

Susol ACB provides you with total solutions with an advanced trip relay for measurement, diagnosis, analysis, and communication as well as protective functions for absolute protective coordination and electric power monitoring system.

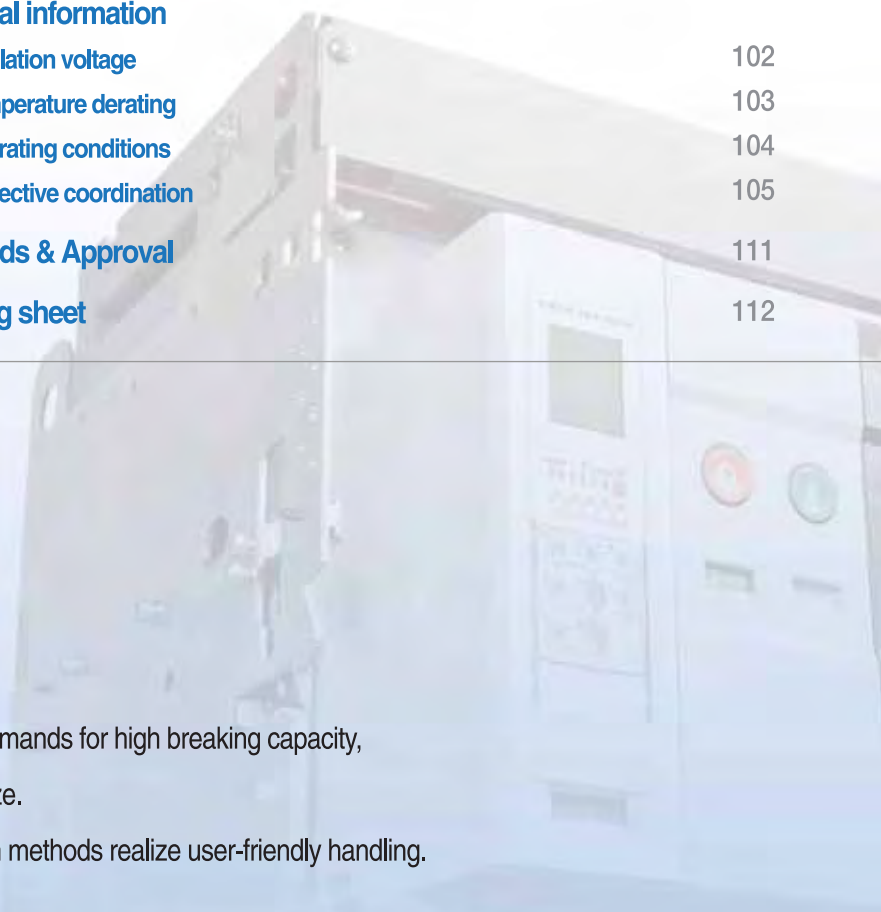

# LS Industrial System *SuperSolution series*



## ■ Susol series circuit breakers are suitable for

- Protection of power distribution
- Protection of motor & its control device
- Controlling and disconnecting circuits

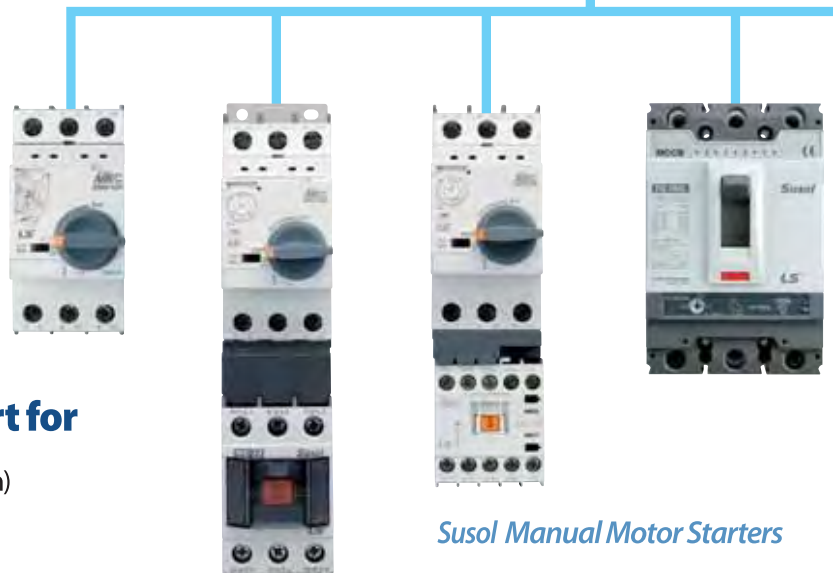

## ■ Optimum technical support for

(Cascading, Discrimination, Type 2 coordination)

- Selecting economical protection system
- Guarantee safety of the installation
- Reducing the stress on components and damage
- Guarantee service continuity

*Susol Manual Motor Starters*



*Susol Air Circuit Breakers*



*Susol Molded Circuit Breakers*



*Susol Magnetic Contactors & Overload Relays*

# Full line-up & Compact

Up to 6300A, Susol ACB provides fully lined-up 3 frame.

For each frame, there is just one size, which is smaller and more compact.

It makes it possible for you to design the optimized volume panel.



85kA ..... 100kA .....

## AH-06-20D

06	630AF
08	800AF
10	1000AF
13	1250AF
16	1600AF
20	2000AF

Icu=Ics=85kA/500Vac  
W=334(3p), 419(4p)mm

## AH-06-40E

06	630AF	20	2000AF
08	800AF	25	2500AF
10	1000AF	32	3200AF
13	1250AF	40	4000AF
16	1600AF		

Icu=Ics=100kA/500Vac  
W=412(3p), 527(4p)mm

4000~6300AF



150kA

- The highest breaking capacity:  
150kA (6300AF at 500Vac)
- 3 ampere frame sizes:  
2000/4000/6300AF
- N phase current conducting capacity: 100%

#### AH-40-63G

40	4000AF
50	5000AF
63	6300AF

Icu=Ics=150kA/500Vac  
W=785(3p), 1015(4p)mm

# Trip Relay (OCR)

*Trip relays are classified according to function.*

Trip relays are classified according to their usages and functions to maximize customers' satisfaction. Classified trip relays and easy installation.

- Protection: overload, short current, ground fault, earth leakage, under voltage, over voltage, under frequency, over frequency, reverse power, unbalance, etc
- Measurement: voltage, ampere, power, energy, frequency, power factor, Harmonics, etc.
- Event & fault recording: Max. 256 events & faults
- Communication: Modbus/RS-485, Profibus-DP



Susol ACB Trip Relay functioning world-best protection can be interlocked with mechanism. It makes the breaking capacity of ACB improved and ACB's life enhanced, and provides advanced functions - measurement, diagnosis, analysis, and communication.



# Susol ACB Trip relay

**N type**



**A type**



**P/S type**



- L/S//I/G/Thermal
- Self Power
- RTC Timer mounted
- Fault information (LED)

- L/S//I/G/Thermal
- ZSI
- Remote Reset
- Modbus/RS-485
- Profibus-DP
- Self Power
- AC/DC 110~220V
- DC 24/48V
- RTC Timer mounted
- Fault Recording (10EA)

- L/S//I/G/Thermal(Continuous)
- UV/OV/OF/UF/rP/Vun/Iun
- Measurement: V/A/W/Wh/F/PF
- Harmonics (63th), Waveform (S Type)
- ZSI
- Remote Reset
- Modbus/RS-485
- Profibus-DP
- AC/DC 110~220V
- DC 24/48V
- RTC Timer mounted
- Event Recording (256EA)
- Fault Recording (256EA)
- Fault Wave (S Type)

## *Trip relays series*



### **N Type (Normal)**

- Self-power + Current protection



### **P Type (Power Meter)**

- A type + Power Meter + Voltage / Frequency / Unbalance protection



### **A Type (Ammeter)**

- Current Meter + Current protection + DO control + Communication



### **S Type (Supreme)**

- P type + Harmonics analysis (63 th) + Fault wave recording

# Accessories

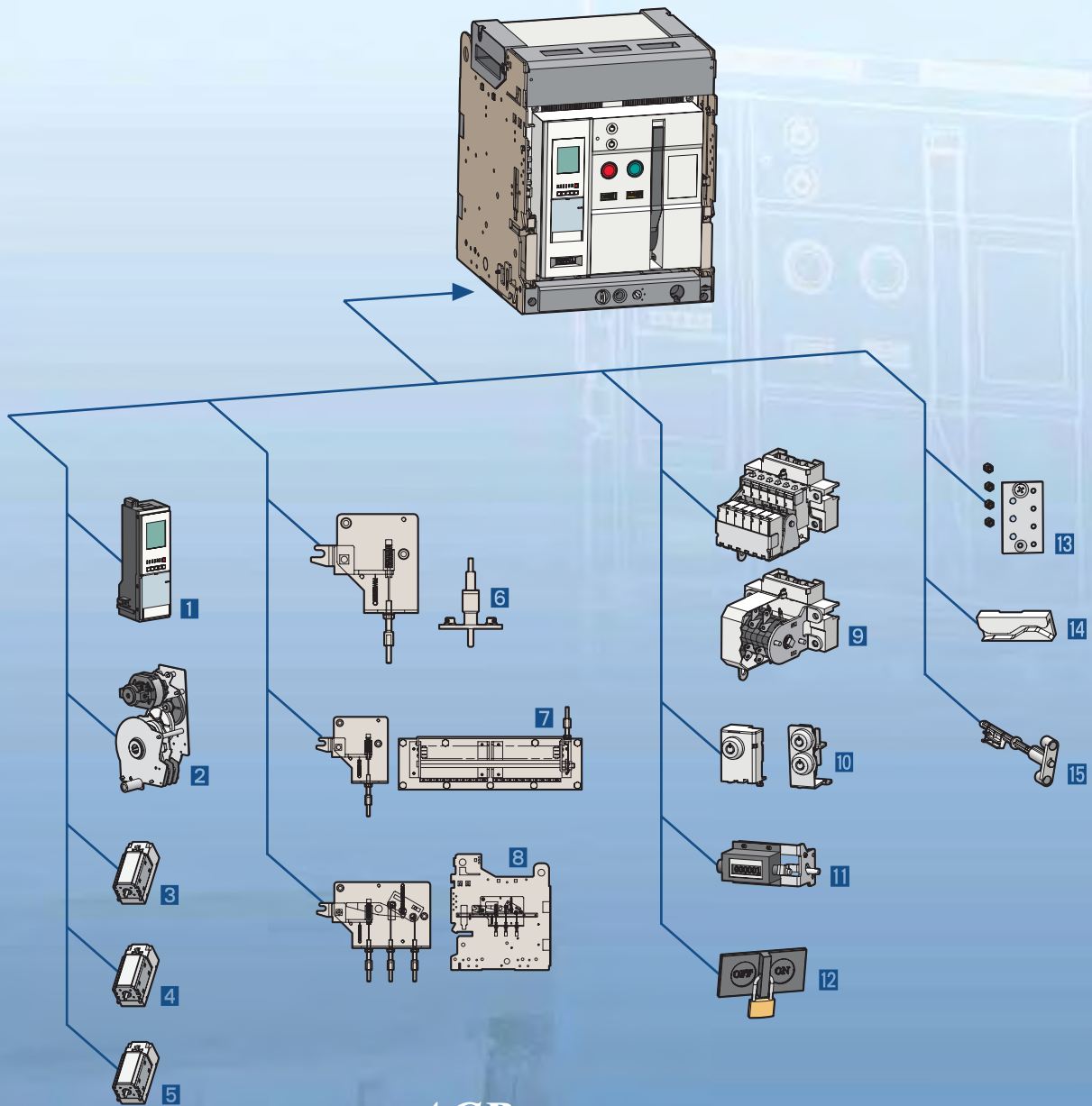

## ACB

- |   |  |
|---|--|
| <b>1</b> Trip Relay (OCR)                           | <b>9</b> Auxiliary Switch (AX)                       |
| <b>2</b> Motor (M)                                  | <b>10</b> Key Lock (K1),<br>Double Key Lock (K3)     |
| <b>3</b> Closing Coil (CC)                          | <b>11</b> Counter (C)                                |
| <b>4</b> Shunt Coil (SHT)                           | <b>12</b> On/Off Button Lock (B)                     |
| <b>5</b> Under Voltage Trip Device (UVT)            | <b>13</b> Miss Insertion Preventing Device (MIP)     |
| <b>6</b> Door Interlock (DI)                        | <b>14</b> Automatically Discharge<br>Mechanism (ADM) |
| <b>7</b> MOC (Mechanically<br>Operated Cell Switch) | <b>15</b> Manual Reset Button (MRB)                  |
| <b>8</b> Mechanical Interlock (MI)                  |  |

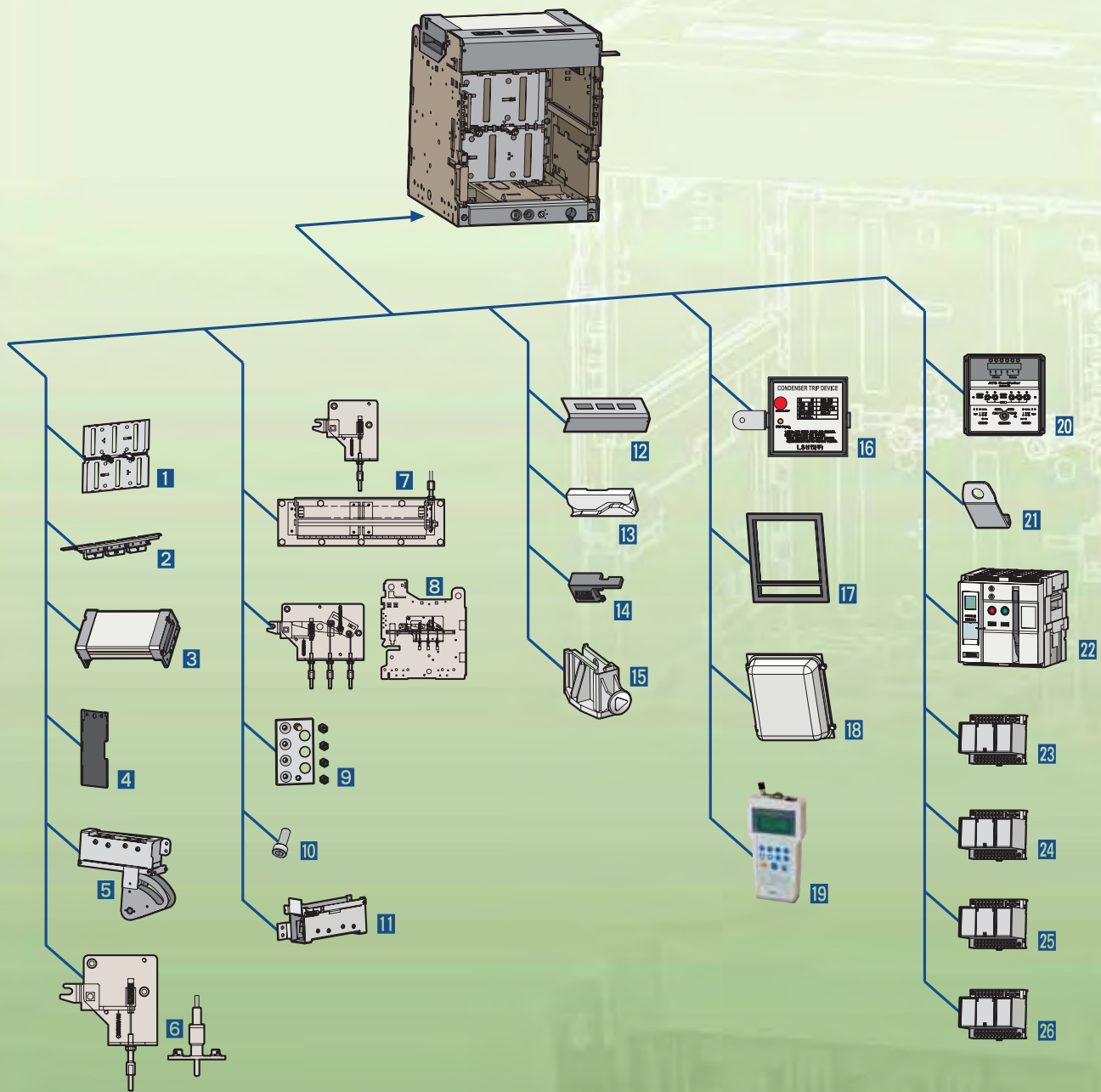

## Cradle

- 1** Safety Shutter (ST)
- 2** Manual Connector
- 3** Zero Arc Space (ZAS)
- 4** Insulation Barrier (IB)
- 5** Cell Switch (CEL)
- 6** Door Interlock (DI)
- 7** MOC (Mechanical Operated Cell switch)
- 8** Mechanical Interlock (MI)
- 9** Miss Insertion Prevent Device (MIP)
- 10** Cradle Mounting Block (CMB)
- 11** Shorting "b" Contact (SBC)
- 12** Safety Control Cover (SC)
- 13** Automatically Discharge Mechanism.(ADM)
- 14** Racking Interlock (RI)
- 15** Safety Shutter Lock (STL)

## Other

- 16** Condenser Trip Device (CTD)
- 17** Door Frame (DF)
- 18** Dust Cover (DC)
- 19** OCR Tester (OT)
- 20** ATS Controller (ATS)
- 21** Lifting Hook (LH)
- 22** Dummy ACB
- 23** UVT Time Delay Controller (UDC)
- 24** Profibus-DP Communication module
- 25** Remote I/O
- 26** Temperature Alarm

# ***Connection and Installation***



Diversified terminal connection methods of the ACB main circuit for users.

# Multiple connections

## *Various installation methods*

### Standard connection



Horizontal type



Vertical type



Front type

### Mixed connection



Horizontal / Vertical type



Vertical / Horizontal type



Horizontal / Front type



Vertical / Front type



Front / Horizontal type



Front / Vertical type

- Front connection type is available to be connected regardless of the depth of main circuit terminal, and it is suited for the panel required for limited installation space.
- The vertical and horizontal type terminal are module types which can easily compose the vertical and horizontal terminals by rotating 90°.

• Please refer to the rating lists (Page 22~25) because the installation method is various according to the rated current.

# External configuration

Susol

## Fixed type ACB



## Terms

- ① Trip relay
- ② Counter
- ③ OFF button
- ④ ON button
- ⑤ Series name
- ⑥ Charge handle
- ⑦ Rated name plate
- ⑧ Charge/Discharge indicator
- ⑨ ON/OFF indicator
- ⑩ Corporation logo
- ⑪ Arc cover
- ⑫ Terminal cover
- ⑬ Cradle
- ⑭ Draw-out handle
- ⑮ Position indicator
- ⑯ Handle storage space
- ⑰ Pad lock button
- ⑱ Arc chute
- ⑲ Control cover
- ⑳ Fixed type bracket

## Draw-out ACB (Cradle)

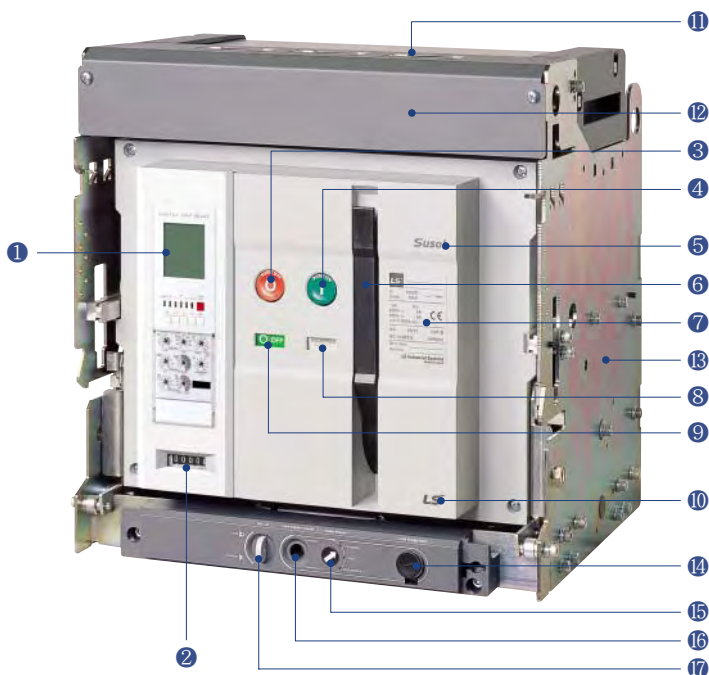

Cradle (Internal)

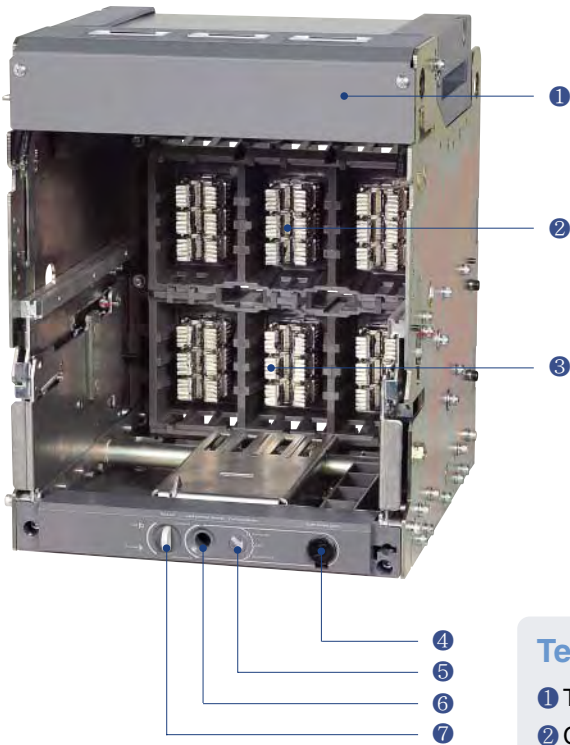

Cradle (Rear)

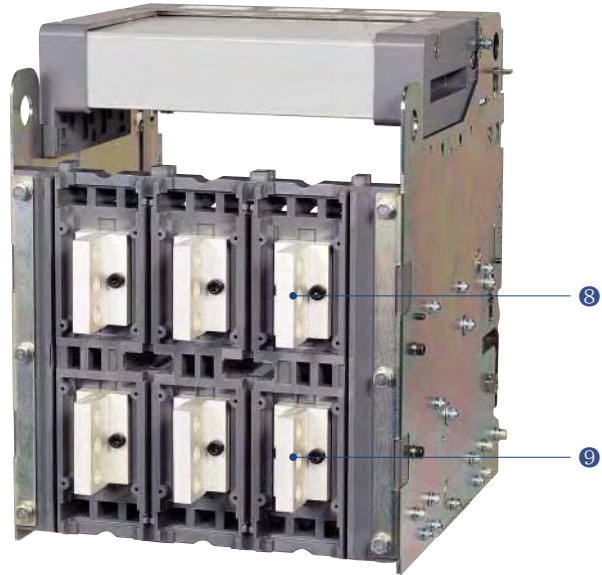

Terms

- ① Terminal cover of control circuit
- ② Cradle finger (Line side)
- ③ Cradle finger (Load side)
- ④ Draw-out handle
- ⑤ Position indicator
- ⑥ Handle storage space
- ⑦ Pad lock button
- ⑧ Connecting conductor (Line side)
- ⑨ Connecting conductor (Load side)

Main nameplate

[Acronym explanation]

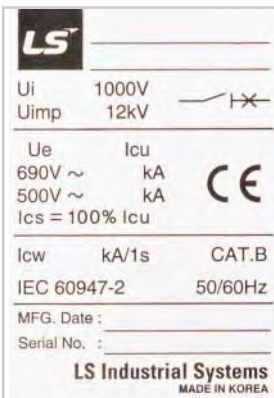

- Ui: Rated insulation voltage
- Uimp: Impulse withstand voltage
- Ue: Rated operational voltage (AC base)
- Icu: Ultimate breaking capacity
- Ics: Service breaking capacity
- Icw: Short time withstand current
- MFG. Date: Manufacturing date

[Secondary nameplate]

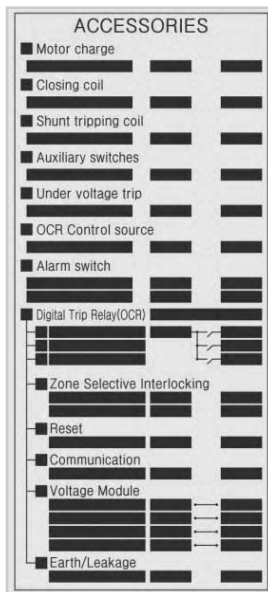

Explanation of terminologies

- Motor charge
- Closing coil
- Shunt tripping coil
- Auxiliary switches: Contact specification and terminal No.
- Under voltage trip: UVT terminal No.
- OCR control source: Trip relay control power
- Alarm switch: Alarm and terminal No.
- Digital trip relay: Switching diagram
- Z.S.I: Input/Output terminal No.
- Reset: Terminal No.
- Communication: Communication and terminal No.
- Voltage module: Phase voltage and symbol
- Earth/Leakage: Ground fault / Earth leakage input terminal No.

# Internal configuration

Susol

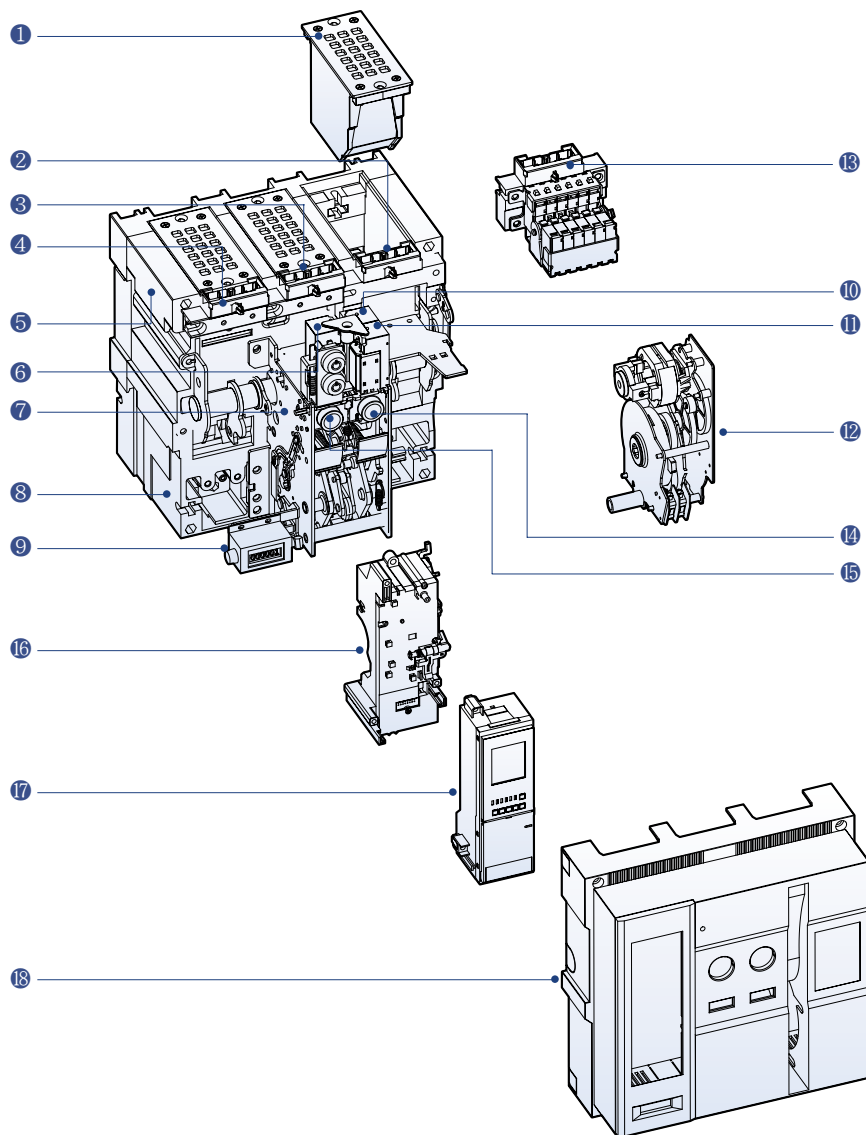

## Terms

- ① Arc chute
- ② Aux. switch control terminal
- ③ Control power supply terminal
- ④ Trip relay control terminal
- ⑤ Carrying grip
- ⑥ Trip coil or UVT coil
- ⑦ Mechanism
- ⑧ Main body
- ⑨ Counter
- ⑩ Trip coil
- ⑪ Closing coil
- ⑫ Motor Ass'y
- ⑬ Aux. switch
- ⑭ ON button
- ⑮ OFF button
- ⑯ MTD base
- ⑰ Trip relay
- ⑱ Front cover





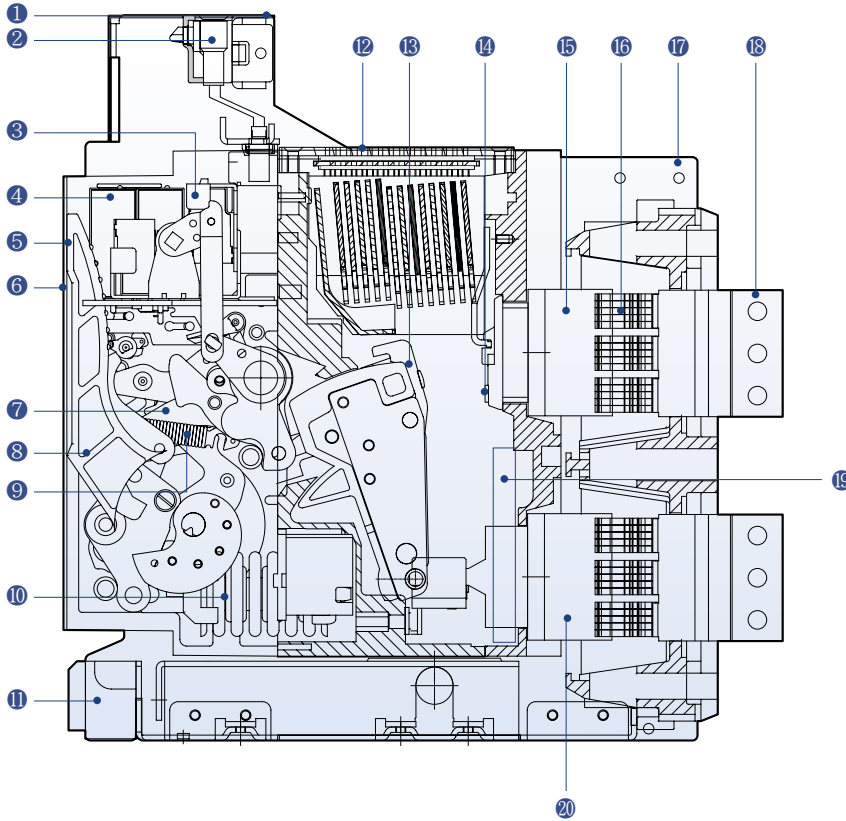

### Terms

- ① Control circuit terminal block
- ② Control terminal
- ③ Auxiliary switches
- ④ Closing, Trip, UVT coil
- ⑤ Trip relay
- ⑥ Front cover
- ⑦ Mechanism
- ⑧ Charge handle
- ⑨ Trip spring
- ⑩ Closing spring
- ⑪ Draw-in/out device
- ⑫ Arc extinguishing part
- ⑬ Moving contact
- ⑭ Fixed contact
- ⑮ Conductor on line side
- ⑯ Cradle finger
- ⑰ Cradle
- ⑱ Connecting conductor
- ⑲ Power supply CT
- ⑳ Conductor on load side

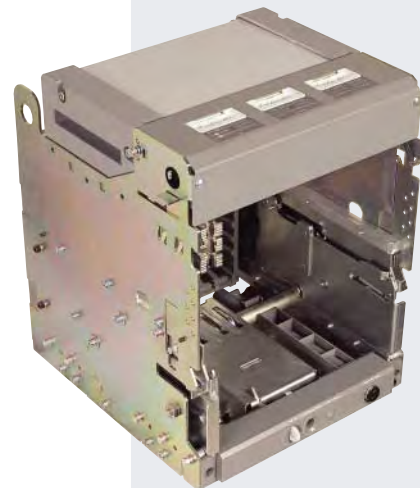



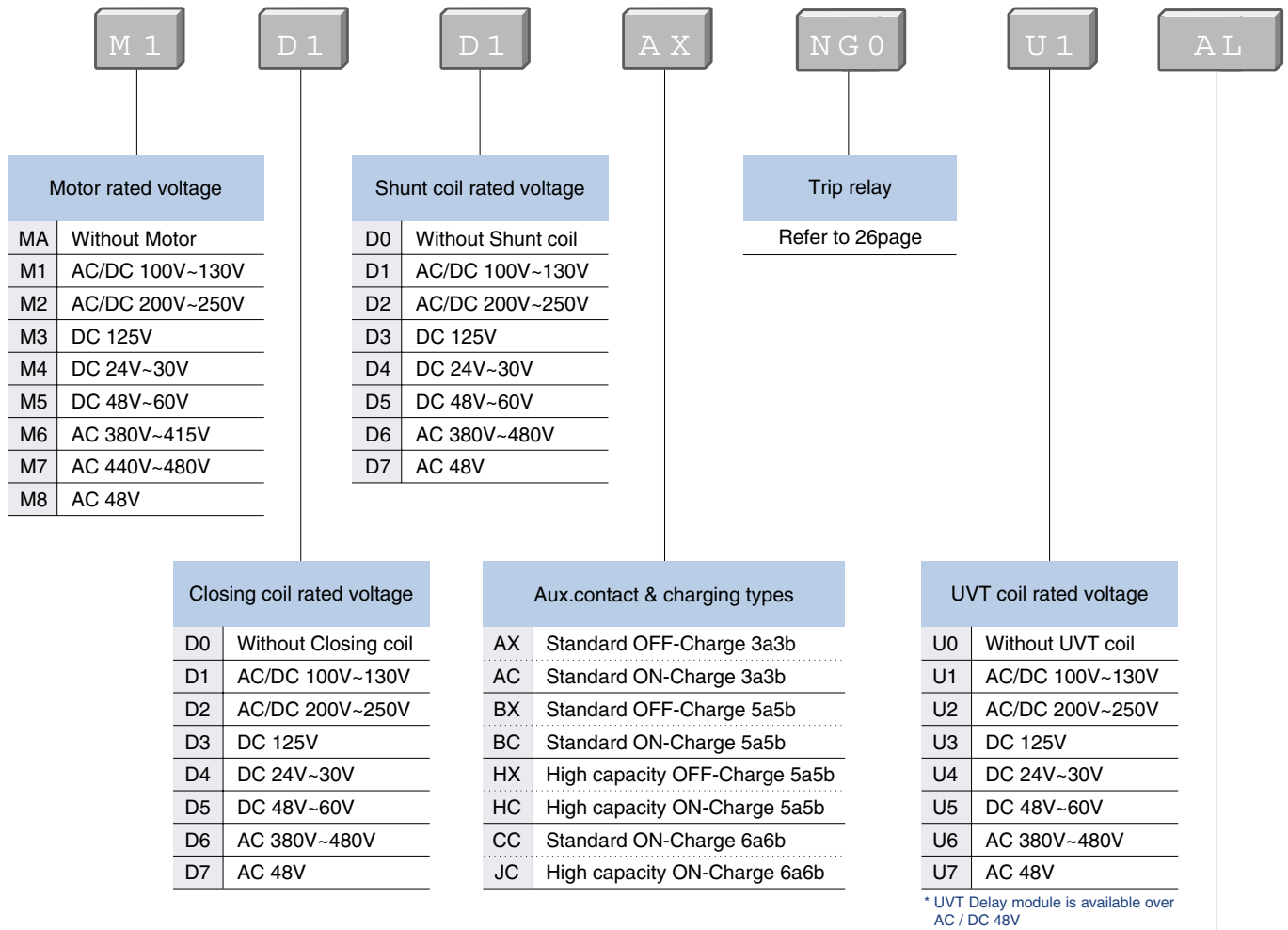

Accessories		
AL	AL1 + MRB	Trip Alarm Contact 1a + Manual Reset Button
A2	AL1 + AL2 + MRB	Trip Alarm Contact 2a + Manual Reset Button
C	C	Counter
S	CS2	Charge Switch Communication
B	B	On/Off Button lock
M	MI	Mechanical Interlock
D	DI or MOC	Door Interlock or Mechanical Operated Cell Switch
K	K1	Key Lock
K2	K2	Key Interlock Set
K3	K3	Double Key Lock
R	RCS	Ready to Close Switch
T	TM	Temperature Alarm
E	ADM	Automatically Discharge Mechanism
H	SHT2	Double Shunt coil

Note) Other accessories should be ordered separately. (Refer to 50page)

# Ordering

Susol

## Cradle

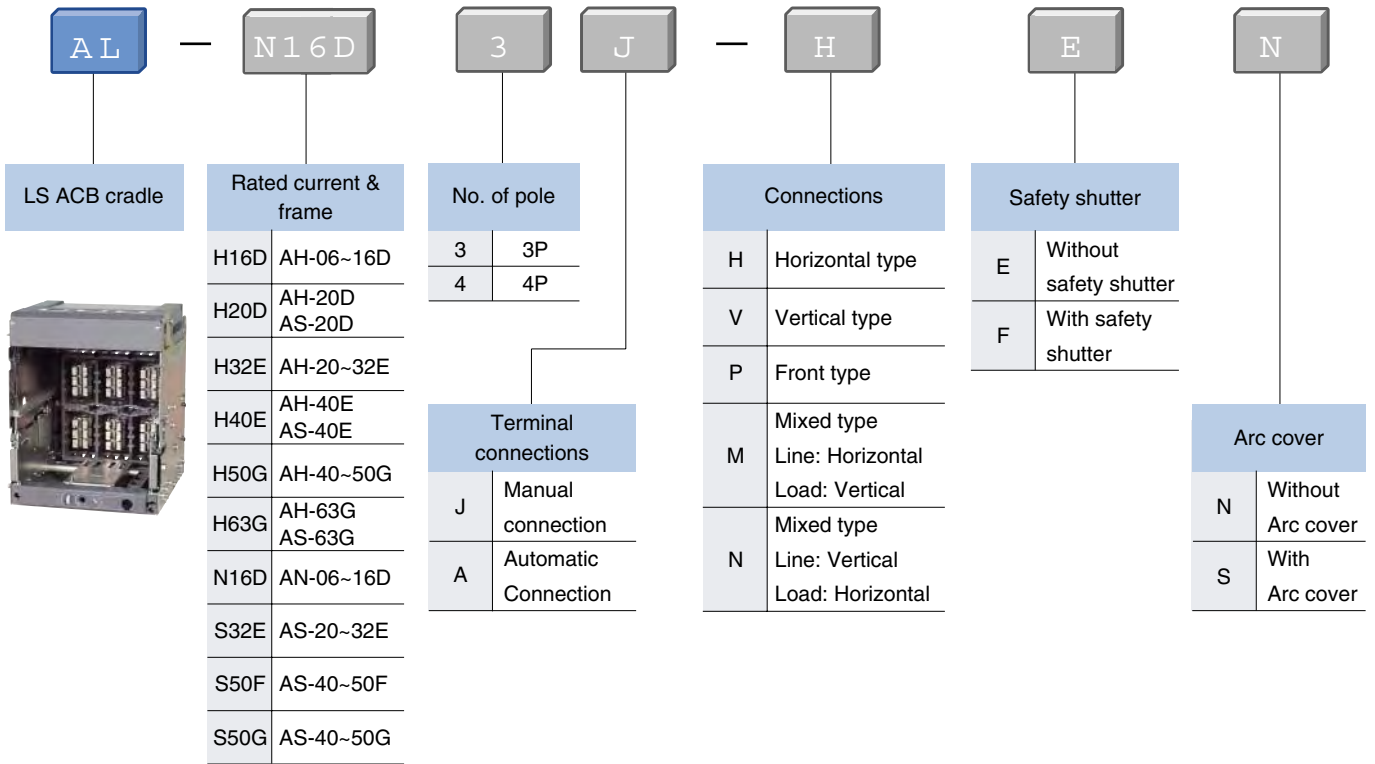

## Trip relay

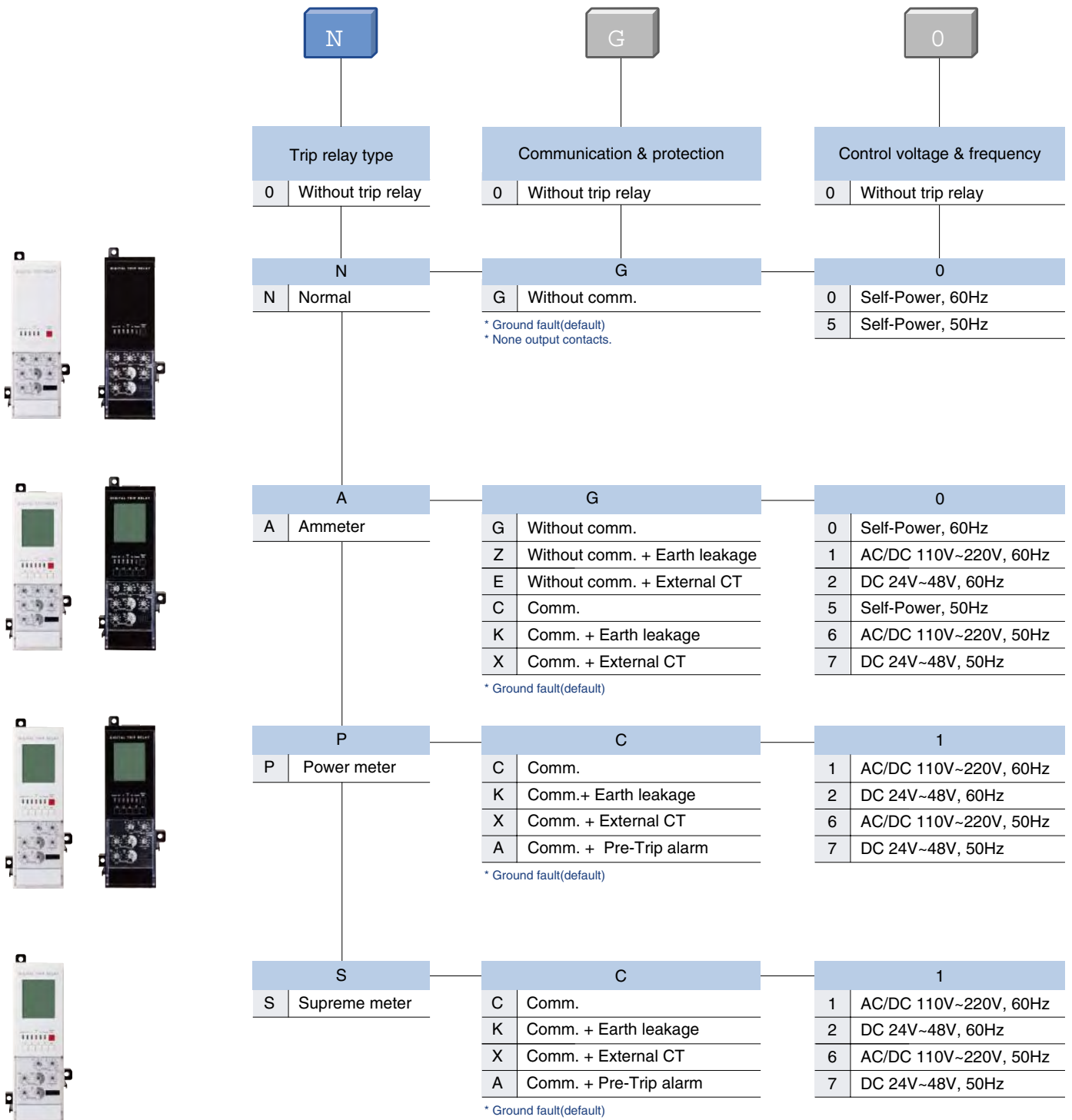

Note) 1. Ground fault (default)  
 2. Measurement, Communication, ZSI, Remote reset, Digital output. (It is only available with control power supply)  
 3. Voltage module (P, S type, default)





Susol			
AH-20E	AH-25E	AH-32E	AH-40E
2000	2500	3200	4000
630, 800 1000, 1250 1600, 2000	2500	3200	4000
(0.4 ~ 1.0) × In max			
630, 800 1000, 1250 1600, 2000	2500	3200	4000
	1,000		
	690		
	12		
	50/60		
	3, 4		
	100		
	100		
	85		
	100%		
	220		
	220		
	187		
	85		
	75		
	65		
	40		
	80		
	10,000		
	20,000		
	5,000		
	10,000		
	●		○
	○		●
	○		-
	○		-
	87/103		104/147
	85/101		102/145
	44/55		58/70
	44/55		63/100
	42/53		61/98
	430×412×375		
	430×527×375		
	300×378×295		
	300×493×295		
	N, A, P, S type		
	KEMA / KERI / CE		

Susol		
AH-40G	AH-50G	AH-63G
4000	5000	6300
4000	5000	6300
(0.4 ~ 1.0) × In max		
4000	5000	6300
	1,000	
	690	
	12	
	50/60	
	3, 4	
	150	
	150	
	100	
	100%	
	330	
	330	
	220	
	100	
	100	
	100	
	40	
	80	
	10,000	
	20,000	
	2,000	
	5,000	
	○	
	●	
	-	
	-	
	181/223	186/230
	179/221	184/228
	97/117	102/124
	98/123	103/130
	96/121	101/128
	460×785×375	
	460×1015×375	
	300×751×295	
	300×981×295	
	N, A, P, S type	
	KEMA / KERI / CE	

# Ratings

Metasol



Type			
Ampere frame	(AF)		
Rated current(A)	(In max)	at 40 °C	
Setting current (A) *	Control trip relay (... × In max)		
Rated current of neutral pole (A)			
Rated insulation voltage(V)	(Ui)		
Rated operating voltage(V)	(Ue)		
Rated impulse withstand voltage (kV)(Uimp)			
Frequency (Hz)			
Number of poles (P)			
Rated breaking capacity (kA sym)		220V/230V/380V/415V	
AC 50/60Hz	(Icu)	IEC 60947-2	460V/480V/500V
		KS C 8325	550V/600V/690V
			... % × Icu
Rated service breaking capacity (kA) (Ics)		100%	
Rated making capacity (kA peak)		143	
AC 50/60Hz	(Icm)	IEC 60947-2	460V/480V/500V
		KS C 8325	550V/600V/690V
			105
Rated short-time withstand current (kA)	(Icw)		1 sec
			2 sec
			3 sec
Operating time (ms)		Maximum total breaking time	
		Maximum closing time	
Life cycle (time)	Mechanical	Without maintenance	
		With maintenance	
	Electrical	Without maintenance	
		With maintenance	
Connections **	Draw-out / Fixed	Horizontal connection	
		Vertical connection	
		Front connection	
		Mixed connection	
Weight (kg) (3P/4P)	Draw-out type	Main body (With cradle)	Motor charging type
			Manual charging type
		Cradle only	
	Fixed type	Motor charging type	
		Manual charging type	
External dimensions (mm) (H×W×D)		Draw-out type	3P
			4P
		Fixed type	3P
			4P
Trip relay			
Certificate & Approval			

Metasol					
AN-06D	AN-08D	AN-10D	AN-13D	AN-16D	AS-20D
630	800	1000	1250	1600	2000
200	400				
400	630	1000	1250	1600	2000
630	800				
(0.4 ~ 1.0) × In max					
400	400				
630	630	1000	1250	1600	2000
	800				
1000					
690					
12					
50/60					
3, 4					
					70
					70
					65
					100%
					154
					154
					143
					65
					55
					50
40					
80					
12,000					
20,000					
5,000					
10,000					
					-
					●
					-
					-
					-
					63/74
					70/85
					61/72
					68/83
					29/32
					33/40
					34/44
					38/47
					32/42
					36/45
430×334×375					
430×419×375					
300×300×295					
300×385×295					
N, A, P type					
KEMA / KERI / CE					

\* Refer to trip relay specification. \*\* ●: Standard, ○: Option





Metasol			
AS-20E	AS-25E	AS-32E	AS-40E
2000	2500	3200	4000
630, 800			
1000, 1250	2500	3200	4000
1600, 2000			
(0.4 ~ 1.0) × In max			
630, 800			
1000, 1250	2500	3200	4000
1600, 2000			
	1,000		
	690		
	12		
	50/60		
	3, 4		
	85		
	85		
	85		
	100%		
	187		
	187		
	187		
	85		
	75		
	65		
	40		
	80		
	10,000		
	20,000		
	5,000		
	10,000		
	●	○	
	○	●	
	○	-	
	○	-	
	87/103	104/147	
	85/101	102/145	
	44/50	58/70	
	44/55	63/100	
	42/53	61/98	
	430 × 412 × 375		
	430 × 527 × 375		
	300 × 378 × 295		
	300 × 493 × 295		
	N, A, P type		
	KEMA / KERI / CE		

Metasol	
AS-50F	
4000	5000
4000	5000
(0.4 ~ 1.0) × In max	
4000	5000
	1000
	690
	12
	50/60
	3, 4
	100
	100
	85
	100%
	220
	220
	187
	85
	75
	65
	40
	80
	10,000
	20,000
	2,000
	5,000
	○
	●
	-
	-
	145/173
	143/171
	78/90
	76/94
	74/92
	460 × 629 × 375
	460 × 799 × 375
	300 × 597 × 295
	300 × 767 × 295
	N, A, P type
	KEMA / KERI / CE

Metasol		
AS-40G	AS-50G	AS-63G
4000	5000	6300
4000	5000	6300
(0.4 ~ 1.0) × In max		
4000	5000	6300
	1,000	
	690	
	12	
	50/60	
	3, 4	
	120	
	120	
	100	
	100%	
	264	
	264	
	220	
	100	
	90	
	85	
	40	
	80	
	10,000	
	20,000	
	2,000	
	5,000	
	○	
	●	
	-	
	-	
	181/223	186/230
	179/221	184/228
	97/117	102/124
	98/123	103/130
	96/121	101/128
	460 × 785 × 375	
	460 × 1015 × 375	
	300 × 751 × 295	
	300 × 981 × 295	
	N, A, P type	
	KEMA / KERI / CE	

# Trip relay(OCR)

The trip relay of Susol ACB provides the additional protection functions for voltage, frequency, unbalance, and others in addition to main protection functions for over current, short-circuit, ground fault. It supports the advanced measurement functions for voltage, current, power, electric energy, harmonics, communication function, and others.

Analog trip function interlocked with mechanism enhanced a durability of devices as well as the breaking capacity of ACB.

Zone selective interlocking function makes the protective coordination more simple and thermal memory can be applied to various loads.







## Contents

Trip relay types	27
N type: 「Normal」 type	28
A type: 「Ammeter」 type	30
P type: 「Power meter」 type	32
S type: 「Supreme meter」 type	34
Operation characteristic	36
Measurement function	38
Man machine interface	39
Protection element setting	40
Measurement element display	41
Characteristic curves	42
ZSI - Zone Selective Interlocking	45
Remote reset and digital I/O	46
Communication	47
Event & fault recording	48
System information	48
System block diagram	49

# Trip relays

Susol

## Trip relay types

Classification	N type	A type	P type	S type
Externals				
Current protection	• L / S / I / G / Thermal	• L / S / I / G / Thermal • ZSI(Protective coordination)	• L / S / I / G / Thermal(Continuous) • ZSI(Protective coordination)	• P type
Other protection		• Earth leakage (Option)	• Earth leakage(Option) • Over/Under current • Over/Under frequency • Unbalance(Voltage/Current) • Reverse power	• P type
Measurement function		• Current (R / S / T / N)	• 3 Phase Voltage/Current RMS/Vector • Power(P, Q, S), PF(3-Phase) • Energy(Positive/Negative) • Frequency, Demand	• 3 Phase Voltage/Current RMS/Vector • Power(P, Q, S), PF(3-Phase) • Energy(Positive/Negative) • Frequency, Demand • Voltage/Current harmonics (1st~63th) • 3 Phase Waveforms • THD, TDD, K-Factor
Fine adjustment			• Fine adjustment for long/short time delay/instantaneous/ ground	• P type
Pre Trip Alarm			• Overload protection relays : DO (Alarm) (Ground fault is not available when using Pre trip alarm)	• P type
Digital Output		• 3DO (Fixed) • L, S/I, G Alarm	• 3DO (Programmable) • Trip, Alarm, General	• P type
IDMTL setting			• Compliance with IEC60255-3 SIT, VIT, EIT, DT	• P type
Communication		• Modbus/RS-485 • Profibus-DP	• Modbus / RS-485 • Profibus-DP	• Modbus / RS-485 • Profibus-DP
Power supply	• Self Power -Power source works over 20% of load current.	• Self Power - Power source works over 20% of load current. - External power source are required for comm. • AC/DC 110~220V • DC 24/48V	• AC/DC 110~220V • DC 24/48V	• AC/DC 110~220V • DC 24/48V
RTC timer	• Available	• Available	• Available	• Available
LED for trip info.	• Long time delay • Short time delay/Instantaneous • Ground fault	• N type	• N type	• N type
Fault recording		• 10records (Fault/Current/Date and Time)	• 256records (Fault/Current/Date and Time)	• 256records • Last fault wave recording (3 Phase)
Event recording			• 256 records(Content, Status, Date)	• P type
Operating button	• Reset button	• Reset, Menu Up/Down, Left/Right, Enter	• A type	• A type

Basic protection function(L / S / I / G) is still under normal operation without control power.

# Trip relays

Susol

## N type: 'Normal' type

- Optimized protection function
- OCR, OCGR function according IEC60947-2
- Overload protection
  - Long-time delay
  - Thermal
- Short-circuit protection
  - Short-time delay / Instantaneous
  - I<sup>2</sup>t On/Off optional (for short-time delay)
- Ground fault protection
  - I<sup>2</sup>t On/Off optional
- Self-Power

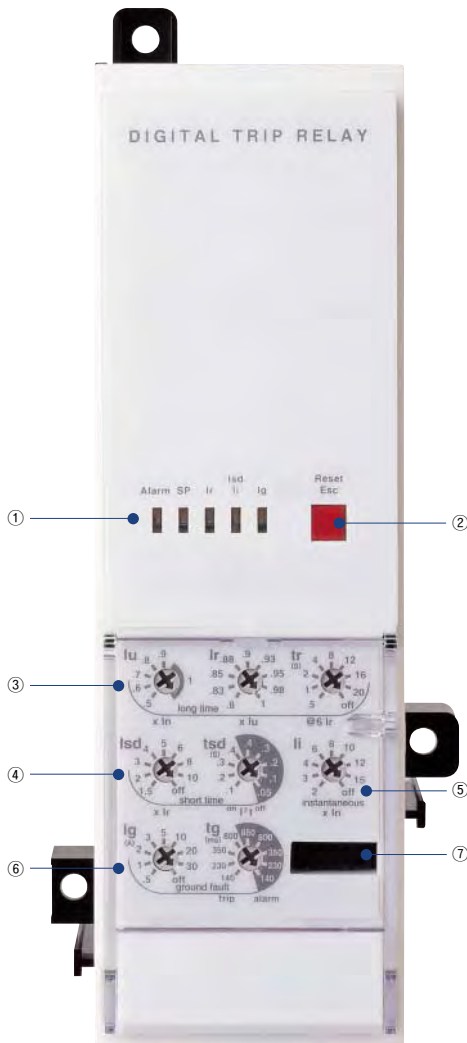

① LED: Indication of trip info. and overload state

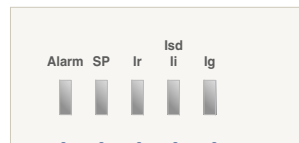

- Ig: LED indicating ground-fault
- I<sub>sd</sub>/I<sub>i</sub>: LED indicating short-time or instantaneous tripping
- I<sub>r</sub>: LED indicating long-time delay
- Batt/SP: Self-protection and battery test LED
- Alarm: LED indicating an overload  
(Turn on above 90%, Blink above 105%)

② Reset Key: Fault reset or battery check

③ I<sub>u</sub>, I<sub>r</sub>: Long-time current setting, t<sub>r</sub>: Long-time tripping delay setting

④ I<sub>s</sub>: Short-time current setting, t<sub>sd</sub>: Short-time tripping delay setting

⑤ I<sub>i</sub>: Instantaneous current setting

⑥ I<sub>g</sub>: Ground fault current setting, t<sub>g</sub>: Ground fault tripping delay setting

⑦ Test terminal: OCR test terminal (Connected with OCR tester)

## Protection

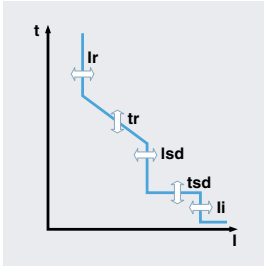

Long time										
Current setting (A)	$I_u = I_n \times \dots$	0.5	0.6	0.7	0.8	0.9	1.0			
	$I_r = I_u \times \dots$	0.8	0.83	0.85	0.88	0.9	0.93	0.95	0.98	1.0
Time delay (s)	$t_r @ (1.5 \times I_r)$	12.5	25	50	100	200	300	400	500	Off
Accuracy: $\pm 15\%$ or below	$t_r @ (6.0 \times I_r)$	0.5	1	2	4	8	12	16	20	Off
100ms	$t_r @ (7.2 \times I_r)$	0.34	0.69	1.38	2.7	5.5	8.3	11	13.8	Off
Thermal memory (s)		66	133	268	537	1076	1615	2154	2693	

Short time											
Current setting (A)	$I_{sd} = I_r \times \dots$	1.5	2	3	4	5	6	8	10	Off	
Accuracy: $\pm 10\%$											
Time delay (s) @ $10 \times I_r$	tsd	$I^{1st} \text{ Off}$	0.05	0.1	0.2	0.3	0.4				
		$I^{1st} \text{ On}$	0.1	0.2	0.3	0.4					
(1 <sup>st</sup> Off)		Min. Trip Time(ms)	20	80	160	260	360				
		Max. Trip Time(ms)	80	140	240	340	440				

Instantaneous										
Current setting (A)	$I_i = I_n \times \dots$	2	3	4	6	8	10	12	15	Off
Tripping time		below 50ms								

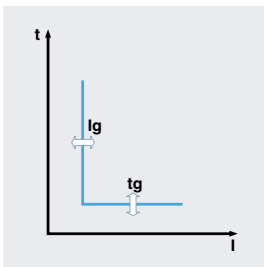

Ground fault											
Pick-up (A)											
Accuracy: $\pm 10\%$ ( $I_g > 0.4 I_n$ ) $\pm 20\%$ ( $I_g \leq 0.4 I_n$ )	$I_g = I_n \times \dots$	0.2	0.3	0.4	0.5	0.6	0.7	0.8	1.0	Off	
Time delay (s) @ $1 \times I_n$	tg	$I^{1st} \text{ Off}$	0.05	0.1	0.2	0.3	0.4				
		$I^{1st} \text{ On}$	0.1	0.2	0.3	0.4					
(1 <sup>st</sup> Off)		Min. Trip Time(ms)	20	80	160	260	360				
		Max. Trip Time(ms)	80	140	240	340	440				

# Trip relays

Susol

## A type: 'Ammeter' type

- Overload protection
  - Long-time delay
  - Thermal
- Short-circuit protection
  - Short-time delay / Instantaneous
  - 1<sup>st</sup> On/Off optional (for short-time delay)
- Ground fault protection
  - 1<sup>st</sup> On/Off optional
- Realization of protective coordination by ZSI (Zone Selective Interlocking)
- High-performance and high-speed MCU built-in
  - Accurate measurement with tolerance of 1.0%
- Fault recording
  - Records Max. up to 10 fault information about fault type, fault phase, fault data, occurrence time of fault
- SBO (Select Before Operation)
  - High reliability for control and setting change method
- 3 DO(Digital Output)
  - Fixed
- Communication
  - Modbus/RS485
  - Profibus-DP

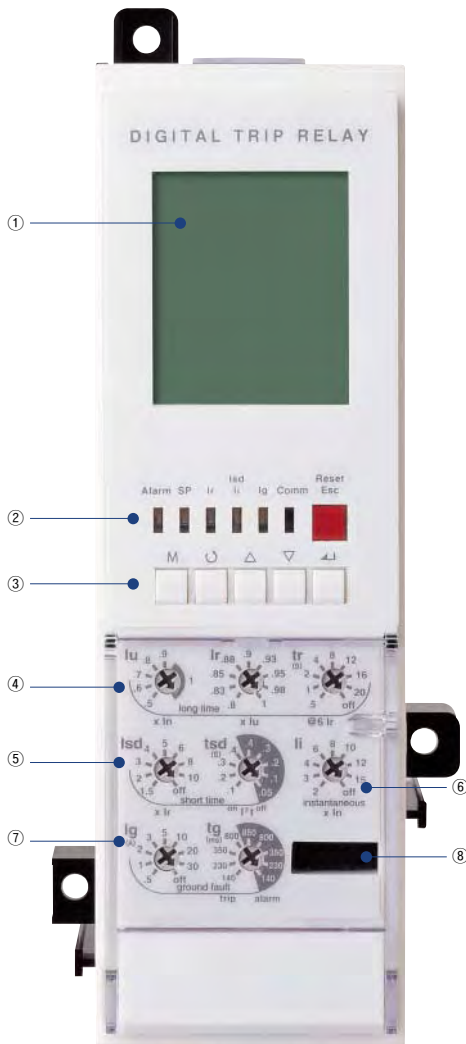

① LCD: Indication of measurement and information

② LED: Indication of trip info. and overload state

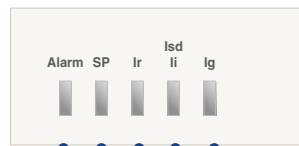

- Ig: LED indicating ground-fault
- lsd/li: LED indicating short-time or instantaneous tripping
- Ir: LED indicating long-time delay
- Batt/SP: Self-protection and battery test LED
- Alarm: LED indicating an overload  
(Turn on above 90%, Blink above 105%)

③ Key: Move to menu or reset

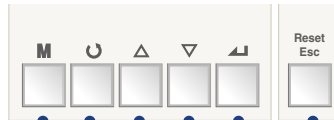

- Reset/ESC: Fault reset or ESC from menu
- Enter: Enter into secondary menu or setting input
- Up/Down: Move the cursor up/down on screen or increase/decrease a setting value
- Right/Left: Move the cursor or setting right/left on screen (Rotation)
- Menu: Menu display ↔ Measurement display

④ lu, lr: Long-time current setting, tr: Long-time tripping delay setting

⑤ ls: Short-time current setting, tsd: Short-time tripping delay setting

⑥ li: Instantaneous current setting

⑦ lg: Ground fault current setting, tg: Ground fault tripping delay setting

⑧ Test terminal: OCR test terminal (Connected with OCR tester)

## Protection

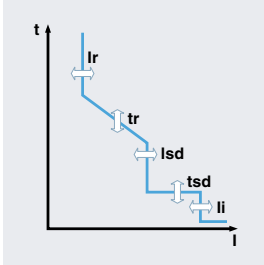

Long time										
Current setting (A)	$I_u = I_n \times \dots$	0.5	0.6	0.7	0.8	0.9	1.0			
	$I_r = I_u \times \dots$	0.8	0.83	0.85	0.88	0.9	0.93	0.95	0.98	1.0
Time delay (s)	$t_r @ (1.5 \times I_r)$	12.5	25	50	100	200	300	400	500	Off
Accuracy: $\pm 15\%$ or below	$t_r @ (6.0 \times I_r)$	0.5	1	2	4	8	12	16	20	Off
100ms	$t_r @ (7.2 \times I_r)$	0.34	0.69	1.38	2.7	5.5	8.3	11	13.8	Off
Thermal memory (s)		66	133	268	537	1076	1615	2154	2693	

Short time											
Current setting (A)	$I_{sd} = I_r \times \dots$	1.5	2	3	4	5	6	8	10	Off	
Accuracy: $\pm 10\%$											
Time delay (s)	$t_{sd}$	$I^1t$ Off	0.05	0.1	0.2	0.3	0.4				
		$I^1t$ On	0.1	0.2	0.3	0.4					
@ $10 \times I_r$	$(I^1t$ Off)	Min. Trip Time(ms)	20	80	160	260	360				
		Max. Trip Time(ms)	80	140	240	340	440				

Instantaneous										
Current setting (A)	$I_{li} = I_n \times \dots$	2	3	4	6	8	10	12	15	Off
Tripping time		below 50ms								

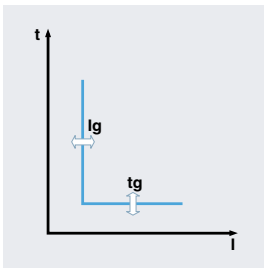

Ground fault											
Pick-up (A)											
Accuracy: $\pm 10\%$ ( $I_g > 0.4I_n$ ) $\pm 20\%$ ( $I_g \leq 0.4I_n$ )	$I_g = I_n \times \dots$	0.2	0.3	0.4	0.5	0.6	0.7	0.8	1.0	Off	
Time delay (s)	$t_g$	$I^1t$ Off	0.05	0.1	0.2	0.3	0.4				
		$I^1t$ On	0.1	0.2	0.3	0.4					
@ $1 \times I_n$	$(I^1t$ Off)	Min. Trip Time(ms)	20	80	160	260	360				
		Max. Trip Time(ms)	80	140	240	340	440				

Earth leakage (Option)											
Current setting (A)	$I_g$	0.5	1	2	3	5	10	20	30	Off	
Time delay (ms)											
Accuracy: $\pm 15\%$	$t_g$	Alarm Time(ms)	140	230	350	800	950				
		Trip Time(ms)	140	230	350	800					

Note) Earth leakage function is available with ZCT or external CT

# Trip relays

Susol

## P type: 'Power meter' type

- Overload protection
  - Long-time delay
  - Thermal
- Short-circuit protection
  - Short-time delay / Instantaneous
  - I<sup>2</sup>t On/Off optional (for short-time delay)
- Ground fault protection
  - I<sup>2</sup>t On/Off optional
- Protection for Over voltage/Under voltage/Over frequency/Under frequency/Unbalance/Reverse power
- Realization of protective coordination by ZSI (Zone Selective Interlocking)
- The fine-adjustable setting by knob and Key
- IDMLT setting (SIT, VIT, EIT, DT curve)
- Measurement and Display Function
  - High detailed measurement for 3 phase current/Voltage/Power/Energy/Phase angle/Frequency/PF/Demand
  - 128 x 128 Graphic LCD
  - Indicates current/voltage Vector Diagram and Waveform
- Fault recording
  - Records Max. up to 256 fault information about fault type, fault phase, fault value, occurrence time of fault
- Event recording
  - Records events of device related to setting change, operation and state change. (Max. up to 256)
- SBO (Select Before Operation)
  - High reliability for control and setting change method
- 3 DO(Digital output)
  - Programmable for alarm, trip and general DO
- Communication
  - Modbus/RS485
  - Profibus-DP

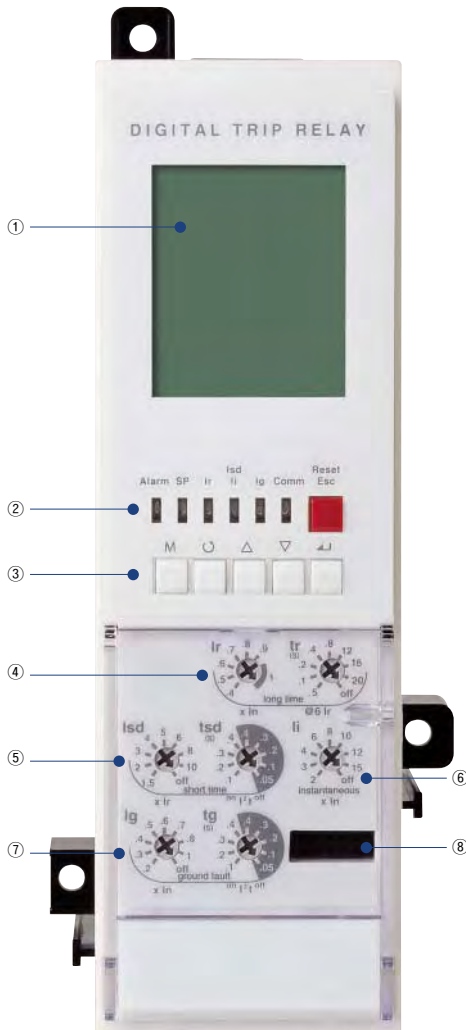

① Graphic LCD: Indication of measurement and information

② LED: Indication of trip info. and overload state

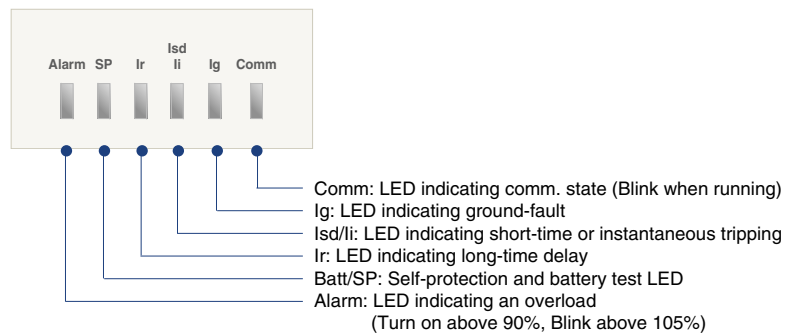

③ Key: Move to menu or reset

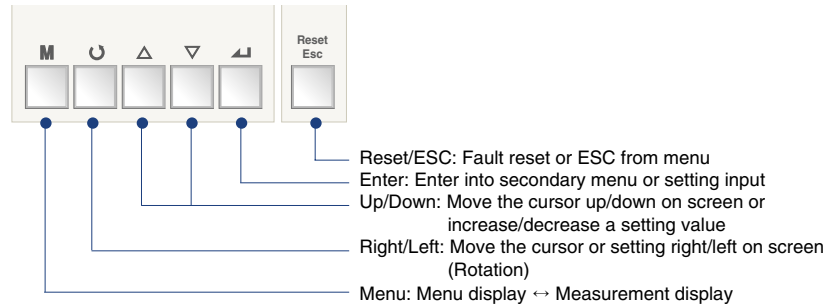

④ I<sub>l</sub>, I<sub>r</sub>: Long-time current setting, t<sub>r</sub>: Long-time tripping delay setting

⑤ I<sub>s</sub>: Short-time current setting, t<sub>sd</sub>: Short-time tripping delay setting

⑥ I<sub>i</sub>: Instantaneous current setting

⑦ I<sub>g</sub>: Ground fault current setting, t<sub>g</sub>: Ground fault tripping delay setting

⑧ Test terminal: OCR test terminal (Connected with OCR tester)



## Protection

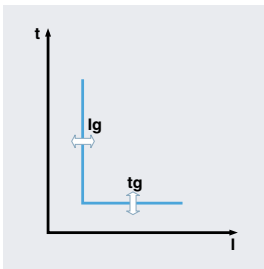
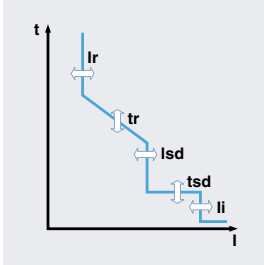

Long time										
Current setting (A)	$I_r = I_n \times \dots$	0.4	0.5	0.6	0.7	0.8	0.9	1.0		
Time delay (s)	$t_r @ (1.5 \times I_r)$	12.5	25	50	100	200	300	400	500	Off
Accuracy: $\pm 15\%$ or below	$t_r @ (6.0 \times I_r)$	0.5	1	2	4	8	12	16	20	Off
100ms	$t_r @ (7.2 \times I_r)$	0.34	0.69	1.38	2.7	5.5	8.3	11	13.8	Off
Thermal memory (s)		66	133	268	537	1076	1615	2154	2693	

Short time											
Current setting (A)	$I_{sd} = I_r \times \dots$	1.5	2	3	4	5	6	8	10	Off	
Accuracy: $\pm 10\%$											
Time delay (s)	$t_{sd}$	$I^2t$ Off	0.05	0.1	0.2	0.3	0.4				
@ $10 \times I_r$		$I^2t$ On	0.1	0.2	0.3	0.4					
		Min. Trip Time(ms)	20	80	160	260	360				
		Max. Trip Time(ms)	80	140	240	340	440				

Instantaneous										
Current setting (A)	$I_i = I_n \times \dots$	2	3	4	6	8	10	12	15	Off
Tripping time		below 50ms								

Ground fault											
Pick-up (A)											
Accuracy: $\pm 10\%$ ( $I_g > 0.4I_n$ ) $\pm 20\%$ ( $I_g \leq 0.4I_n$ )	$I_g = I_n \times \dots$	0.2	0.3	0.4	0.5	0.6	0.7	0.8	1.0	Off	
		$I^2t$ Off	0.05	0.1	0.2	0.3	0.4				
		$I^2t$ On	0.1	0.2	0.3	0.4					
Time delay (s)		Min. Trip Time(ms)	20	80	160	260	360				
@ $1 \times I_n$		Max. Trip Time(ms)	80	140	240	340	440				

Earth leakage (Option)											
Current setting (A)	$I_g$	0.5	1	2	3	5	10	20	30	Off	
Time delay (ms)											
Accuracy: $\pm 15\%$											
	$t_g$	Alarm Time(ms)	140	230	350	800	950				
		Trip Time(ms)	140	230	350	800					

Note) Earth leakage function is available with ZCT or external CT

PTA(Pre Trip Alarm)										
Current setting (A)	$I_p = I_r \times \dots$	0.6	0.65	0.7	0.75	0.8	0.85	0.9	0.95	1
Time delay (s)	$t_p @ (1.2 \times I_p)$	1	5	10	15	20	25	30	35	Off
Accuracy: $\pm 15\%$										

Other protection	Pick-up			Time delay(s)		
	Setting range	Step	Accuracy	Setting range	Step	Accuracy
Under voltage	80V ~ OV_Pick-up	1V	$\pm 5\%$	1.2~40sec	0.1sec	$\pm 0.1sec$
Over voltage	UV_Pick-up ~ 980V	1V	$\pm 5\%$			
Voltage unbalance	6% ~ 99%	1%	$\pm 2.5\%$ or ( $* \pm 10\%$ )			
Reverse power	10 ~ 500kW	1kW	$\pm 10\%$			
Current unbalance	6% ~ 99%	1%	$\pm 2.5\%$ or ( $* \pm 10\%$ )			
Over frequency	60Hz UF_Pick-up ~ 65	1Hz	$\pm 0.1Hz$			
Under frequency	50Hz UF_Pick-up ~ 55	1Hz	$\pm 0.1Hz$			
Over frequency	60Hz 55Hz ~ OF_Pick-up	1Hz	$\pm 0.1Hz$			
Under frequency	50Hz 45Hz ~ OF_Pick-up	1Hz	$\pm 0.1Hz$			

# Trip relays

Susol

## S type: 'Supreme meter' type

- Overload protection
  - Long-time delay
  - Thermal
- Short-circuit protection
  - Short-time delay / Instantaneous
  - I<sup>2</sup>t On/Off optional (for short-time delay)
- Ground fault protection
  - I<sup>2</sup>t On/Off optional
- Protection for Over voltage/Under voltage/Over frequency/Under frequency/Unbalance/Reverse power
- Realization of protective coordination by ZSI (Zone Selective Interlocking)
- The fine-adjustable setting by knob and Key
- IDMLT setting (SIT, VIT, EIT, DT curve)
- Measurement and Display Function
  - High detailed measurement for 3 phase current/Voltage/Power/Energy/Phase angle/Frequency/PF/Demand
  - 128 x 128 Graphic LCD
  - Indicates current/voltage Vector Diagram and Waveform
- Fault recording
  - Records Max. up to 256 fault information about fault type, fault phase, fault value, occurrence time of fault
  - Fault wave recording: records the latest fault wave
- Event recording
  - Records events of device related to setting change, operation and state change. (Max. up to 256)
- SBO (Select Before Operation)
  - High reliability for control and setting change method
- Power quality analysis
  - Measurement for 1st~63th harmonics
  - THD, TDD, k-Factor
  - Voltage/current waveform capture
- 3 DO(Digital output)
  - Programmable for alarm, trip and general DO
- Communication
  - Modbus/RS485
  - Profibus-DP

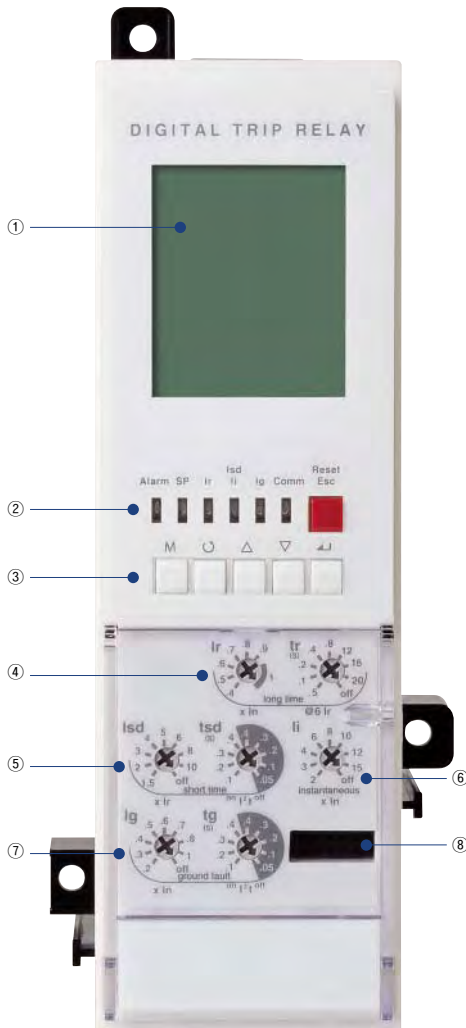

① Graphic LCD: Indication of measurement and information

② LED: Indication of trip info. and overload state

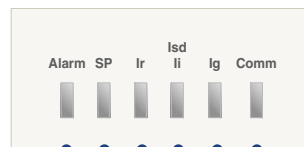

- Comm: LED indicating comm. state (Blink when running)
- Ig: LED indicating ground-fault
- Isd/li: LED indicating short-time or instantaneous tripping
- Ir: LED indicating long-time delay
- Batt/SP: Self-protection LED and battery test LED
- Alarm: LED indicating an overload  
(Turn on above 90%, Blink above 105%)

③ Key: Move to menu or reset

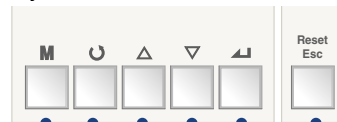

- Reset/ESC: Fault reset or ESC from menu
- Enter: Enter into secondary menu or setting input
- Up/Down: Move the cursor up/down on screen or increase/decrease a setting value
- Right/Left: Move the cursor or setting right/left on screen (Rotation)
- Menu: Menu display ↔ Measurement display

④ I<sub>u</sub>, I<sub>r</sub>: Long-time current setting, t<sub>r</sub>: Long-time tripping delay setting

⑤ I<sub>s</sub>: Short-time current setting, t<sub>sd</sub>: Short-time tripping delay setting

⑥ I<sub>i</sub>: Instantaneous current setting

⑦ I<sub>g</sub>: Ground fault current setting, t<sub>g</sub>: Ground fault tripping delay setting

⑧ Test terminal: OCR test terminal (Connected with OCR tester)

## Protection

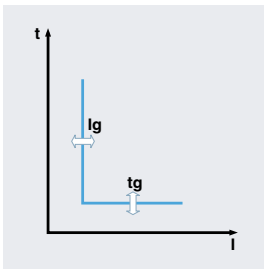
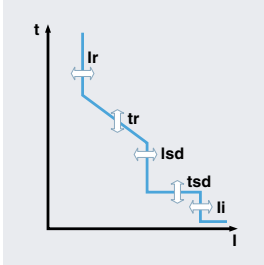

Long time										
Current setting (A)	$I_u = I_n \times \dots$	0.4	0.5	0.6	0.7	0.8	0.9	1.0		
Time delay (s)	$t_r @ (1.5 \times I_r)$	12.5	25	50	100	200	300	400	500	Off
Accuracy: $\pm 15\%$ or below	$t_r @ (6.0 \times I_r)$	0.5	1	2	4	6	12	16	20	Off
100ms	$t_r @ (7.2 \times I_r)$	0.34	0.69	1.38	2.7	5.5	8.3	11	13.8	Off
Thermal memory (s)		66	133	268	537	1076	1615	2154	2693	

Short time											
Current setting (A)	$I_{sd} = I_r \times \dots$	1.5	2	3	4	5	6	8	10	Off	
Accuracy: $\pm 10\%$											
Time delay (s) @ $10 \times I_r$	tsd	I <sup>1st</sup> Off	0.05	0.1	0.2	0.3	0.4				
		I <sup>1st</sup> On		0.1	0.2	0.3	0.4				
(I <sup>1st</sup> Off)		Min. Trip Time(ms)	20	80	160	260	360				
		Max. Trip Time(ms)	80	140	240	340	440				

Instantaneous										
Current setting (A)	$I_i = I_n \times \dots$	2	3	4	6	8	10	12	15	Off
Tripping time		below 50ms								

Ground fault											
Pick-up (A)											
Accuracy: $\pm 10\%$ ( $I_g > 0.4 I_n$ ) $\pm 20\%$ ( $I_g \leq 0.4 I_n$ )	$I_g = I_n \times \dots$	0.2	0.3	0.4	0.5	0.6	0.7	0.8	1.0	Off	
Time delay (s) @ $1 \times I_n$	tg	I <sup>1st</sup> Off	0.05	0.1	0.2	0.3	0.4				
		I <sup>1st</sup> On		0.1	0.2	0.3	0.4				
(I <sup>1st</sup> Off)		Min. Trip Time(ms)	20	80	160	260	360				
		Max. Trip Time(ms)	80	140	240	340	440				

Earth leakage (Option)											
Current setting (A)	$I_g$	0.5	1	2	3	5	10	20	30	Off	
Time delay (ms) Accuracy: $\pm 15\%$	tg	Alarm Time(ms)	140	230	350	800	950				
		Trip Time(ms)	140	230	350	800					

Note) Earth leakage function is available with ZCT or external CT

PTA(Pre Trip Alarm)										
Current setting (A)	$I_p = I_r \times \dots$	0.6	0.65	0.7	0.75	0.8	0.85	0.9	0.95	1
Time delay (s)	$t_p @ (1.2 \times I_p)$	1	5	10	15	20	25	30	35	Off
Accuracy: $\pm 15\%$										

Other protection	Pick-up			Time delay(s)		
	Setting range	Step	Accuracy	Setting range	Step	Accuracy
Under voltage	80V ~ OV_Pick-up	1V	$\pm 5\%$	1.2~40sec	0.1sec	$\pm 0.1sec$
Over voltage	UV_Pick-up ~ 980V	1V	$\pm 5\%$			
Voltage unbalance	6% ~ 99%	1%	$\pm 2.5\%$ or ( $* \pm 10\%$ )			
Reverse power	10 ~ 500kW	1kW	$\pm 10\%$			
Current unbalance	6% ~ 99%	1%	$\pm 2.5\%$ or ( $* \pm 10\%$ )			
Over frequency	60Hz UF_Pick-up ~ 65	1Hz	$\pm 0.1Hz$			
Under frequency	50Hz UF_Pick-up ~ 55	1Hz	$\pm 0.1Hz$			
Over frequency	60Hz 55Hz ~ OF_Pick-up	1Hz	$\pm 0.1Hz$			
Under frequency	50Hz 45Hz ~ OF_Pick-up	1Hz	$\pm 0.1Hz$			

# Trip relays

Susol

## Operation characteristic

### Long-time delay (L)

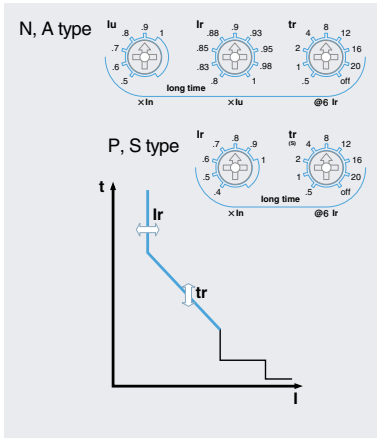

The function for overload protection which has time delayed characteristic in inverse ratio to fault current.

- Standard current setting knob:  $I_r$ 
  - Setting range in P type and S type:  $(0.4-0.5-0.6-0.7-0.8-0.9-1.0) \times I_n$
  - Setting range in N type and A type:  $(0.4 \sim 1.0) \times I_n$ 
    - $l_u$ :  $(0.5-0.6-0.7-0.8-0.9-1.0) \times I_n$
    - $I_r$ :  $(0.8-0.83-0.85-0.88-0.9-0.93-0.95-0.98-1.0) \times I_n$
- Time delay setting knob:  $t_r$ 
  - Standard operating time is based on the time of  $6 \times I_r$
  - Setting range: 0.5-1-2-4-8-12-16-20-Off sec (9 modes)
- Relay pick-up current
  - When current over  $(1.15) \times I_r$  flows in, relay is picked up.
- Relay operates basing on the largest load current among R/S/T/N phase.

### Short-time delay (S)

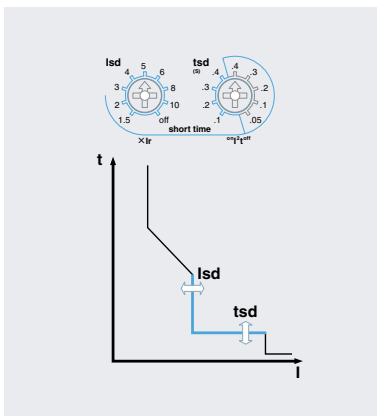

The function for fault current (over current) protection which has definite time characteristic and time delayed in inverse ratio to fault current.

- Standard current setting knob:  $I_{sd}$ 
  - Setting range:  $(1.5-2-3-4-5-6-8-10-Off) \times I_r$
- Time delay setting knob:  $t_{sd}$ 
  - Standard operating time is based on the time of  $10 \times I_{sd}$ .
  - Inverse time ( $I^2t$  On): 0.1-0.2-0.3-0.4 sec
  - Definite time ( $I^2t$  Off): 0.05-0.1-0.2-0.3-0.4 sec
- Relay operates basing on the largest load current among R/S/T/N phase.
- Relay can operate at instantaneous current through ZSI.

### Instantaneous (I)

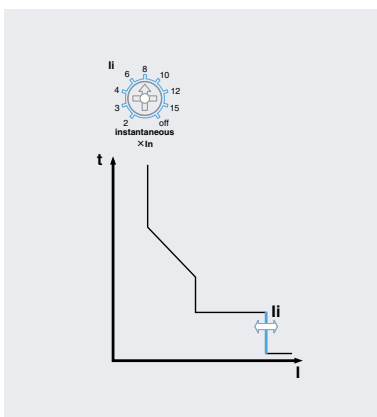

The function for breaking fault current above the setting value within the shortest time to protect the circuit from short-circuit.

- Standard current setting knob:  $I_i$ 
  - Setting range:  $(2-3-4-6-8-10-12-15-Off) \times I_n$
- Relay operates basing on the largest load current among R/S/T/N phase.
- Total breaking time is below 50ms.

## Ground Fault (G)

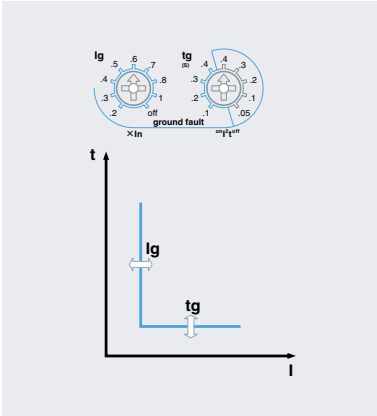

The function for breaking ground fault current above setting value after time-delay to protect the circuit from ground fault.

1. Standard setting current knob:  $I_g$ 
  - Setting range:  $(0.2-0.3-0.4-0.5-0.6-0.7-0.8-1.0-Off) \times I_n$
2. Time delay setting knob:  $t_g$ 
  - Inverse time ( $I^2t$  On): 0.1-0.2-0.3-0.4 sec
  - Definite time ( $I^2t$  Off): 0.05-0.1-0.2-0.3-0.4 sec
3. Ground fault current =  $R+S+T+N$ (Vector Sum)
4. Relay can operate at instantaneous current through ZSI.
5. The protection for ground fault is a basic function of Trip relay (Internal CT type)

## Earth Leakage (G) - Option

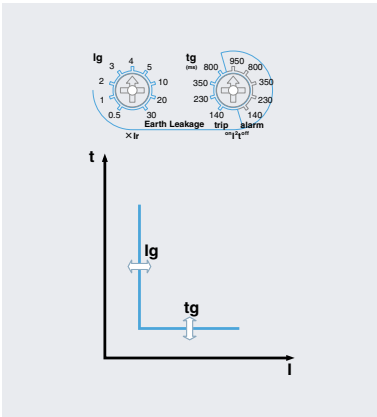

The function for breaking earth leakage current above setting value after time delay to protect the circuit from earth leakage. (A, P, S type)

1. Standard setting current knob:  $I_g$ 
  - Setting range: 0.5-1-2-3-4-5-10-20-30-Off (A)
2. Time delay setting knob:  $t_g$ 
  - Trip time: 140-230-350-800 ms
  - Alarm time: 140-230-350-800-950 ms
3. It is only available with private ZCT or general purpose external CT.

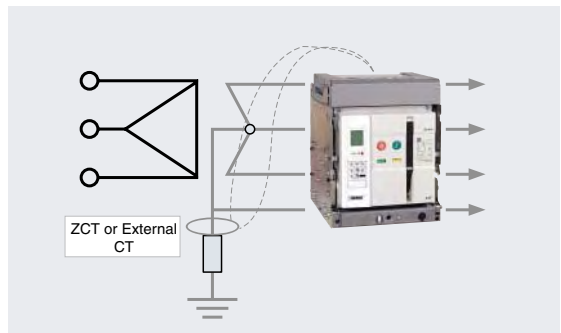
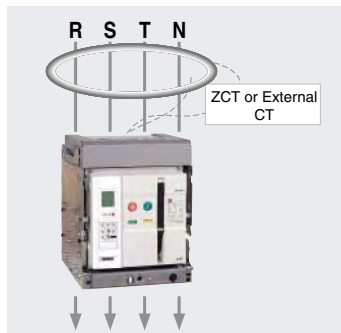

### ※ The necessity of earth leakage relay with external CT

- Earth leakage relay with Internal CT (standard) operates in the range of 20% ~100% of the rated current.
- If the rated current of ACB increases, the standard operating current of earth leakage relay also increases.
  - ex) 400AF ACB of Min. earth leakage relay current,  $400A \times 20\% = 80A$
  - 4000AF ACB of Min. earth leakage relay current,  $4000A \times 20\% = 800A$
- Thus, Susol ACB provides a solution with CT which can be installed externally to adjust sensibility of earth leakage current and which can operate relay. (separate purchase)

# Trip relays

Susol

## Measurement function

Class.	Measurement element	Detailed element	Unit	Display range	Accuracy
Current	Line current	$I_a, I_b, I_c$	A	80A~65,535A	±3%
	Normal current	$I_1$			
	Reverse current	$I_2$			
Voltage	Line voltage	$V_{ab}, V_{bc}, V_{ca}$	V	60~690V	±1%
	Phase voltage	$V_a, V_b, V_c$			±1%
	Normal voltage	$V_1$			
	Reverse voltage	$V_2$			
Angle	Line-to-line	$\angle V_{abla}, \angle V_{b\Delta}, \angle V_{c\Delta}$	°	0~360 °	±1 °
	Line-to-current	$\angle V_{ab}V_{bc}, \angle V_{ab}V_{ca}$			±1 °
	Phase-to-phase	$\angle V_aV_b, \angle V_aV_c$			±1 °
	Phase-to-current	$\angle V_aI_a, \angle V_bI_b, \angle V_cI_c$			±1 °
Power	Active power	$P_{a(ab)}, P_{b(bc)}, P_{c(ca)}, P$	kW	1kW~99,999kW	±3%
	Reactive power	$Q_{a(ab)}, Q_{b(bc)}, Q_{c(ca)}, Q$	kVar	1kVar~99,999kVar	±3%
	Apparent power	$S_{a(ab)}, S_{b(bc)}, S_{c(ca)}, S$	kVA	1kVA~99,999kVA	±3%
Energy	Active energy	$WH_{a(ab)}, WH_{b(bc)}, WH_{c(ca)}, WH$	kWh MWh	1kWh~9999.99MWh	±3%
	Reactive energy	$VARH_{a(ab)}, VARH_{b(bc)}, VARH_{c(ca)}, VARH$	kVarh Mvarh	1kVarh~9999.99MVarh	±3%
	Reverse active energy	$rWH_{a(ab)}, rWH_{b(bc)}, rWH_{c(ca)}, rWH$	kWh MWh	1kWh ~9999.99MWh	±3%
Freq.	Frequency	F	Hz	45~65Hz	
Power factor	Power factor(PF)	$PF_{a(ab)}, PF_{b(bc)}, PF_{c(ca)}, PF$		+ : Lead, - : Lag	
Unbalance	Unbalance rate	$I_{unbalance}, V_{unbalance}$	%	0.0~100.0	
Demand	Active power demand	Peak demand	kW	1kW~99999kW	
	Current demand	Peak demand	A	80A~65,535A	
Harmonics	Voltage harmonics	1st~63th harmonics of $V_{a(ab)}, V_{b(bc)}, V_{c(ca)}$	V	60~690V	
	Current harmonics	1st~63th harmonics of $I_a, I_b, I_c$	A	80A~65,535A	
	THD, TDD		%	0.0~100.0	
	K-Factor		-	0.0~100.0	

A type  
P type  
S type

### Voltage module

For P and S type Trip relay, separate voltage module is provided to measure other element besides current  
- Voltage input range: AC 60~690V

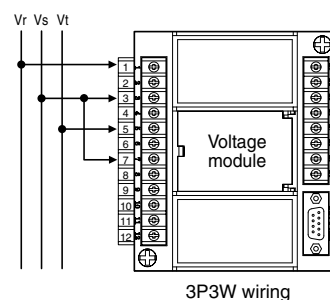
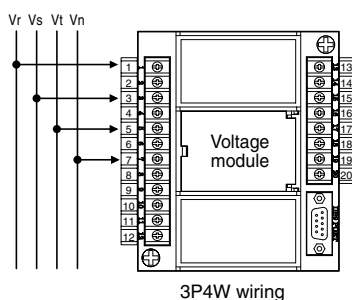

## Man machine interface

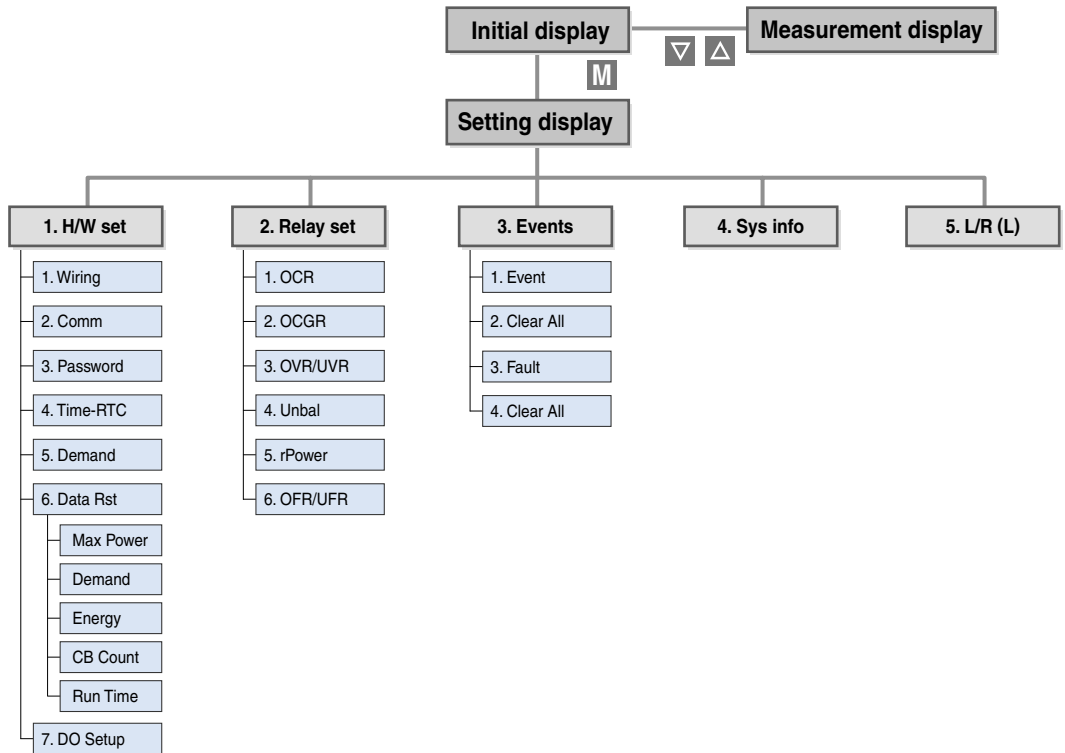
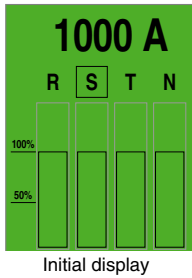

## An example of graphic LCD display

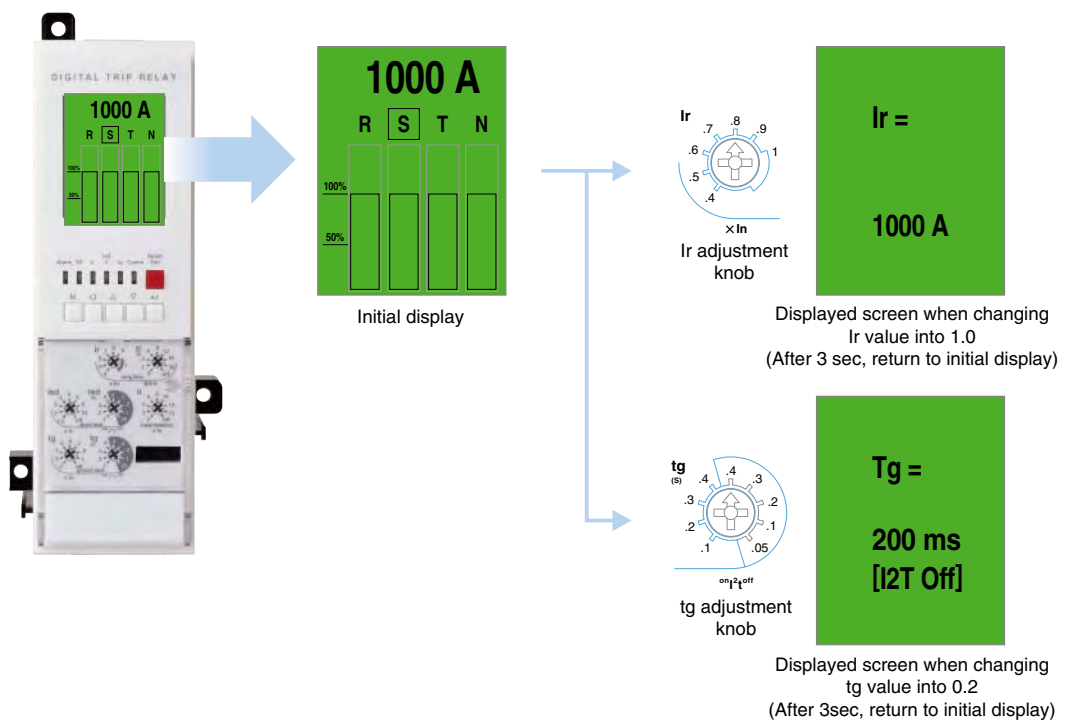

# Trip relays

Susol

## Protection element setting

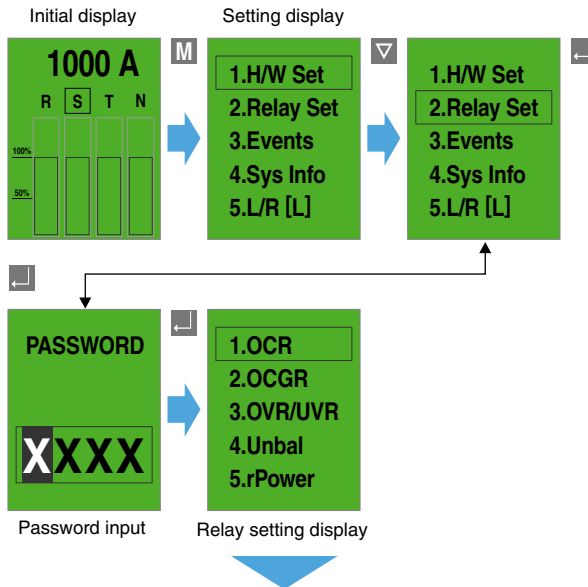

## Find adjustment of protection setting current

- OCR and OCGR's current setting is basically controlled by knob's setting values.
- The fine current that cannot be controlled by knob is adjustable by using  $\nabla$ ,  $\Delta$  key.
- Fine adjustment is only adjustable in the present knob and next knob's setting range, when moving knob, the adjusted data becomes reset state.

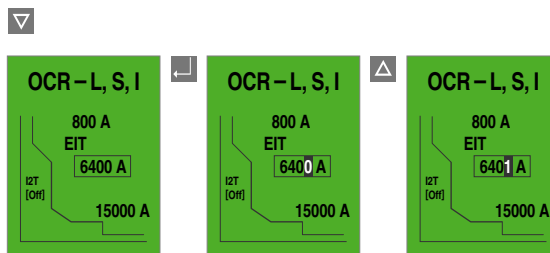
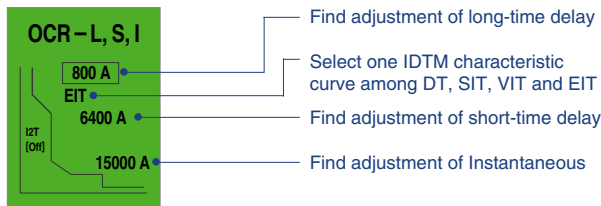

- The setting method of OCGR is same with OCR's, fine adjustment is available.

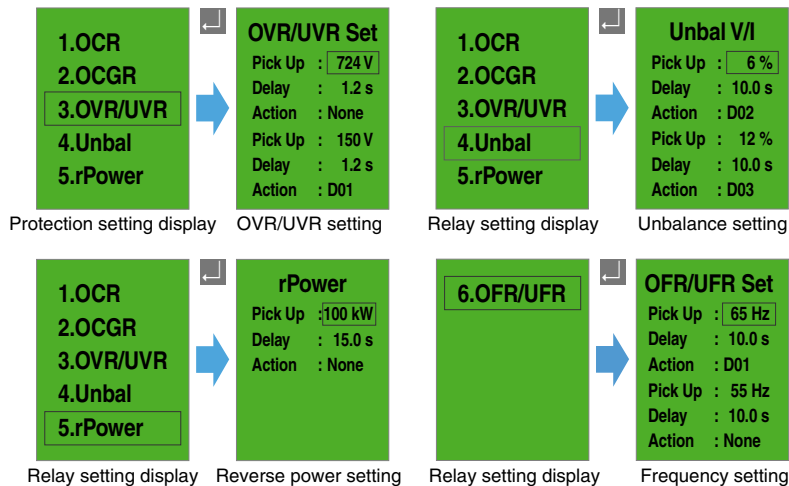



## Measurement element display

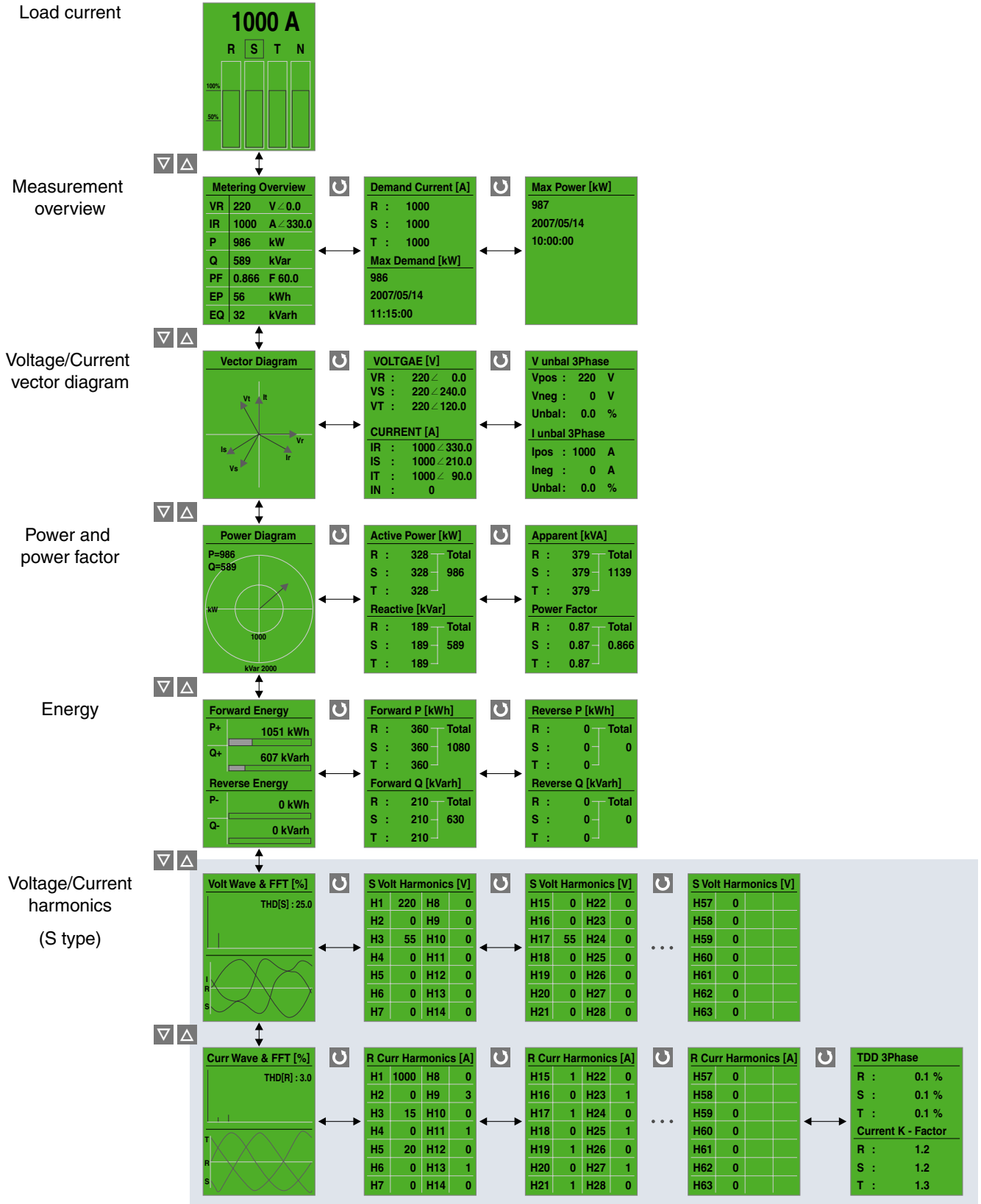

# Trip relays

Susol

## Characteristic curves

Long-time delay (L)  
Short-time delay (S)  
Instantaneous (I)

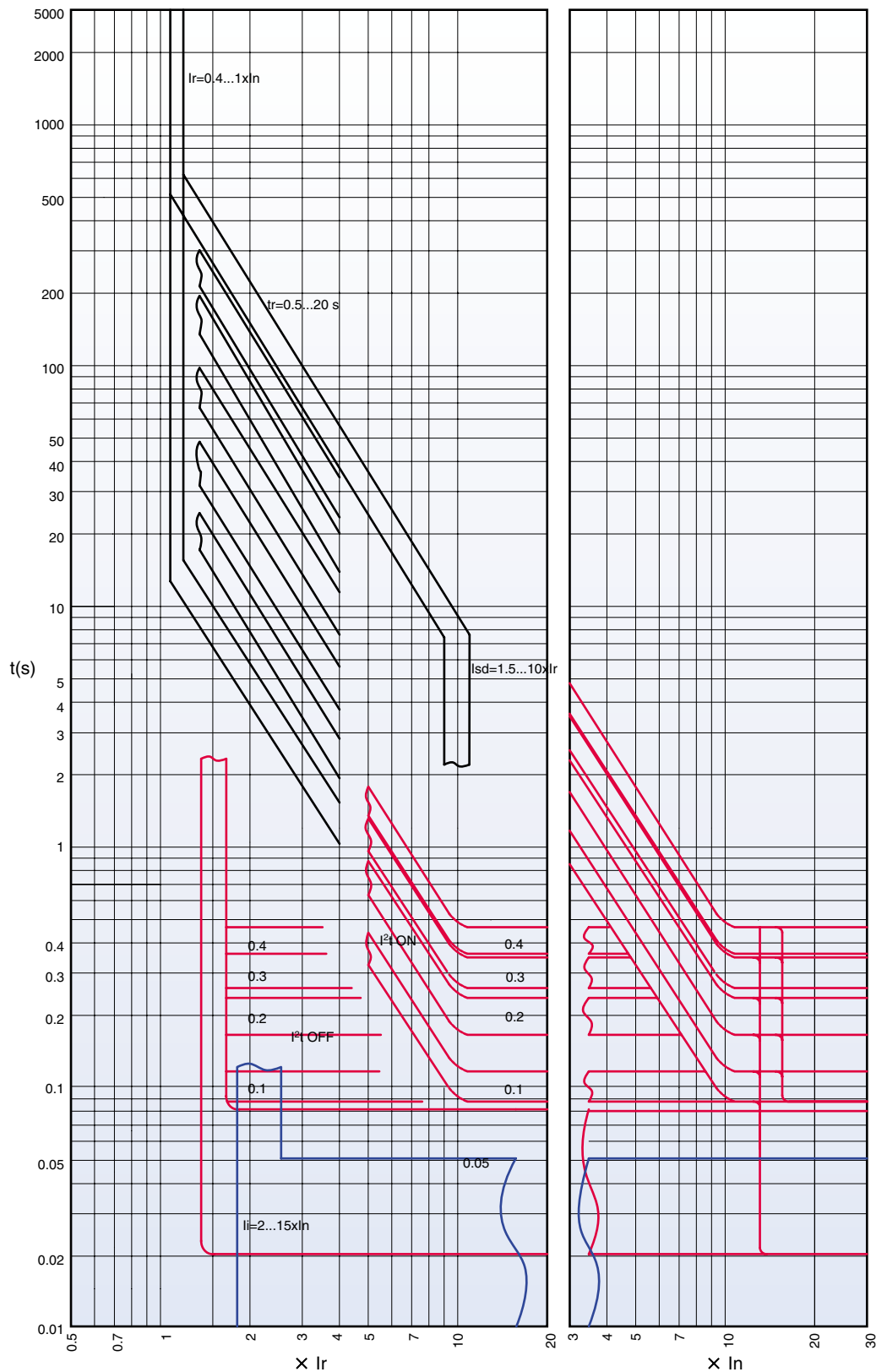

### Ground fault (G)

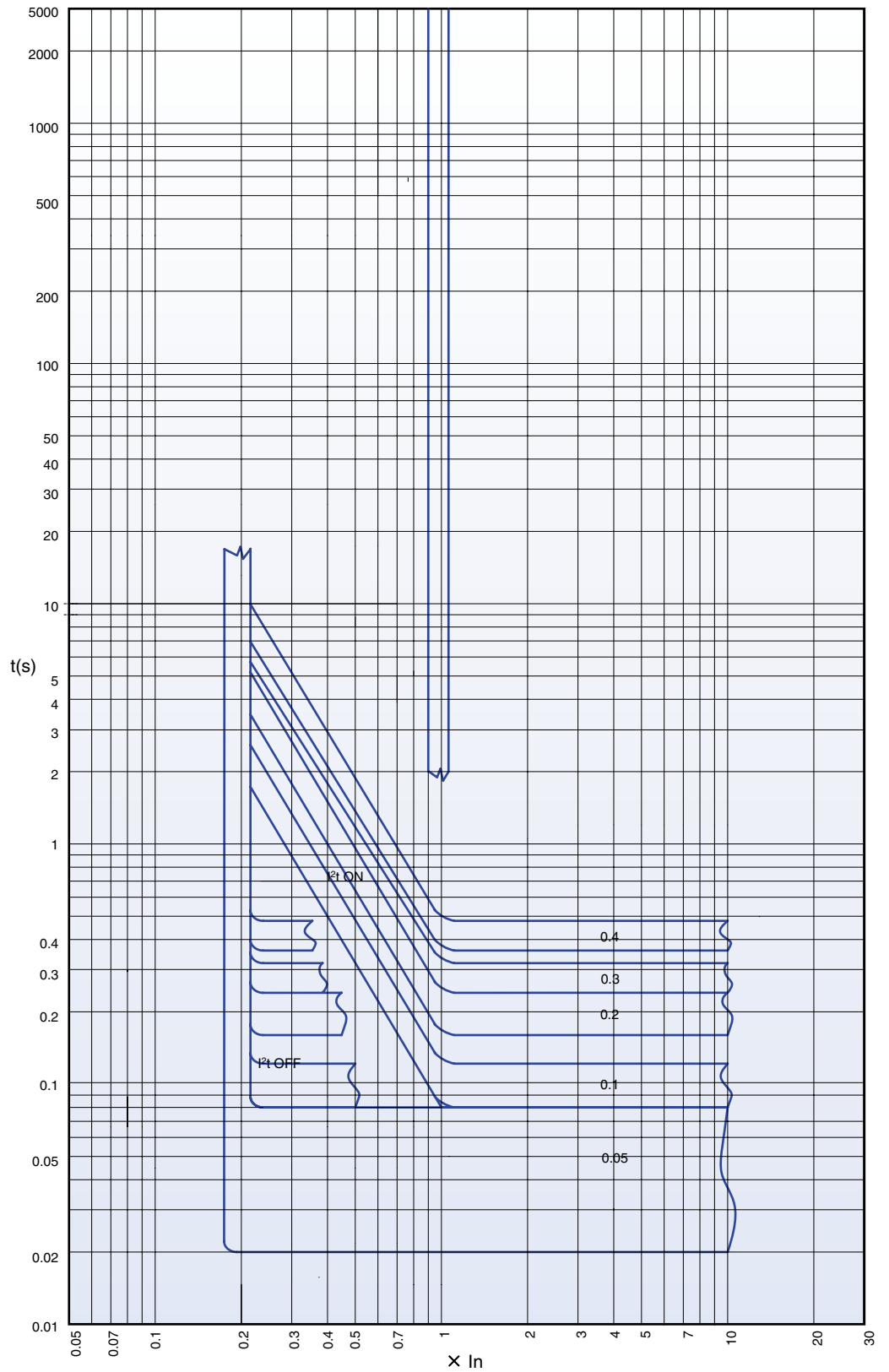

# Trip relays

Susol

## Characteristic curves

### IDMTL

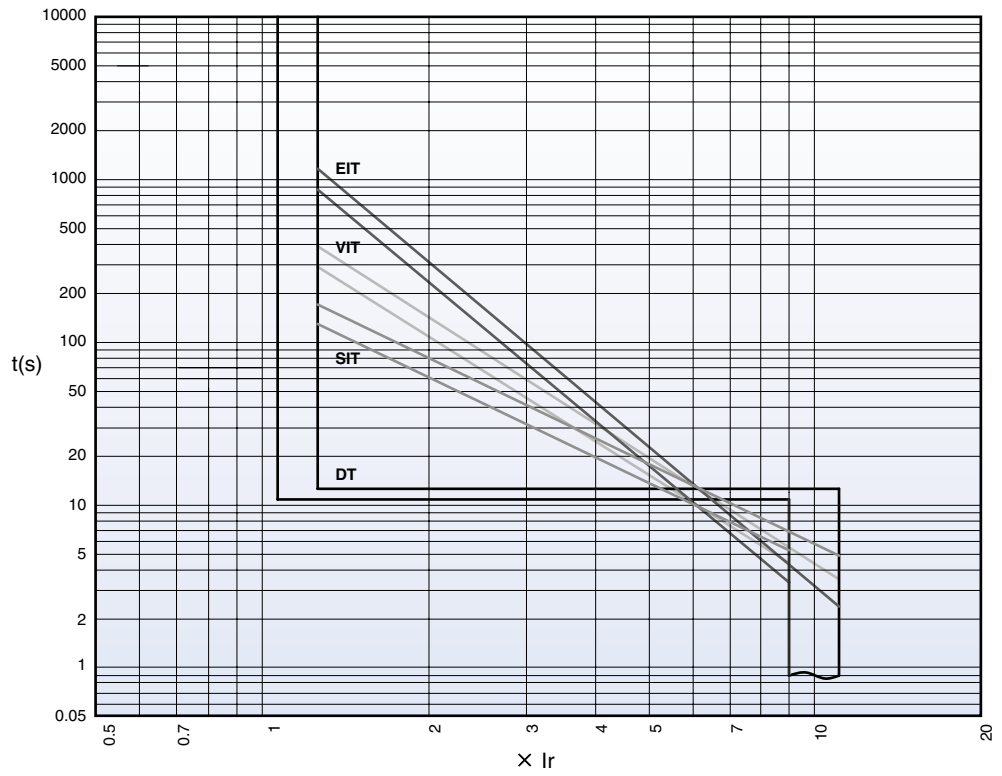

### Pre Trip Alarm

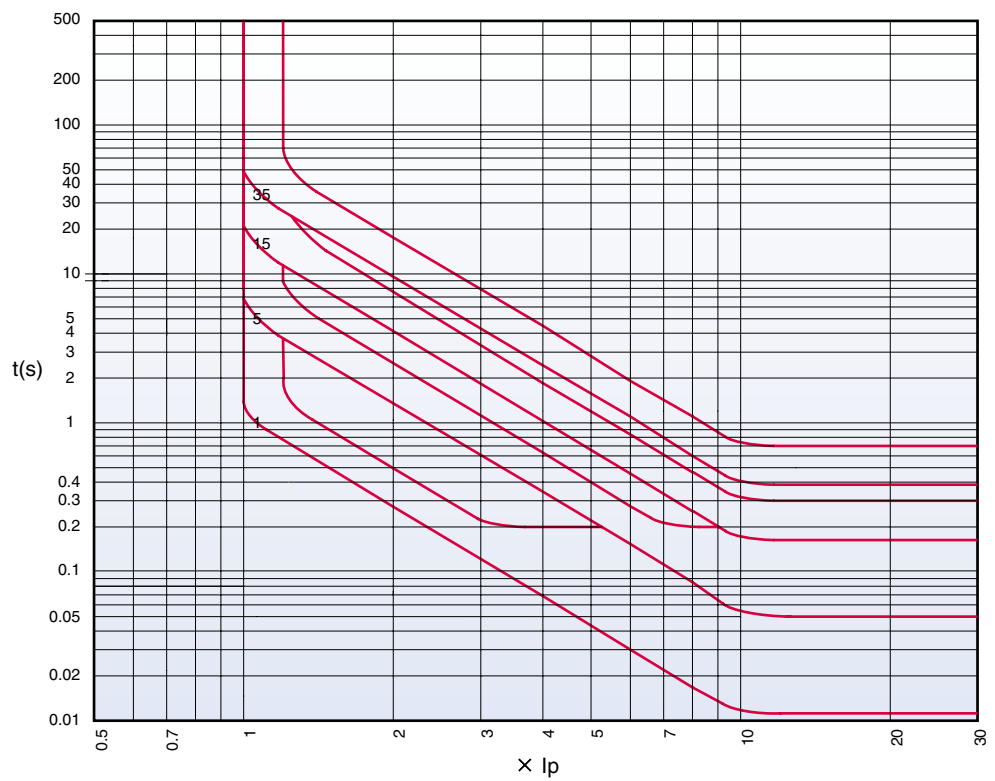

## ZSI - Zone Selective Interlocking (A, P, S type)

**Zone-selective interlocking drops delay time that eliminates faults for breakers. It minimizes the shock that all kinds of electric machineries get under fault conditions.**

1. In case of that short time-delay or ground fault accident occurs at ZSI built in system, the breaker at accident site sends ZSI signal to halt upstream breaker's operation.
2. To eliminate a breakdown, trip relay of ACB at accident site activates trip operation without time delay.
3. The upstream breaker that received ZSI signal adhere to pre-set short time-delay or ground fault time-delay for protective coordination in the system. However upstream breaker that did not receive its signal will trip instantaneously.
4. For ordinary ZSI operation, it should arrange operation time accordingly so that downstream circuit breakers will react before upstream ones under overcurrent/short time delay/ground fault situations.
5. ZSI connecting line needs to be Max. 3m.

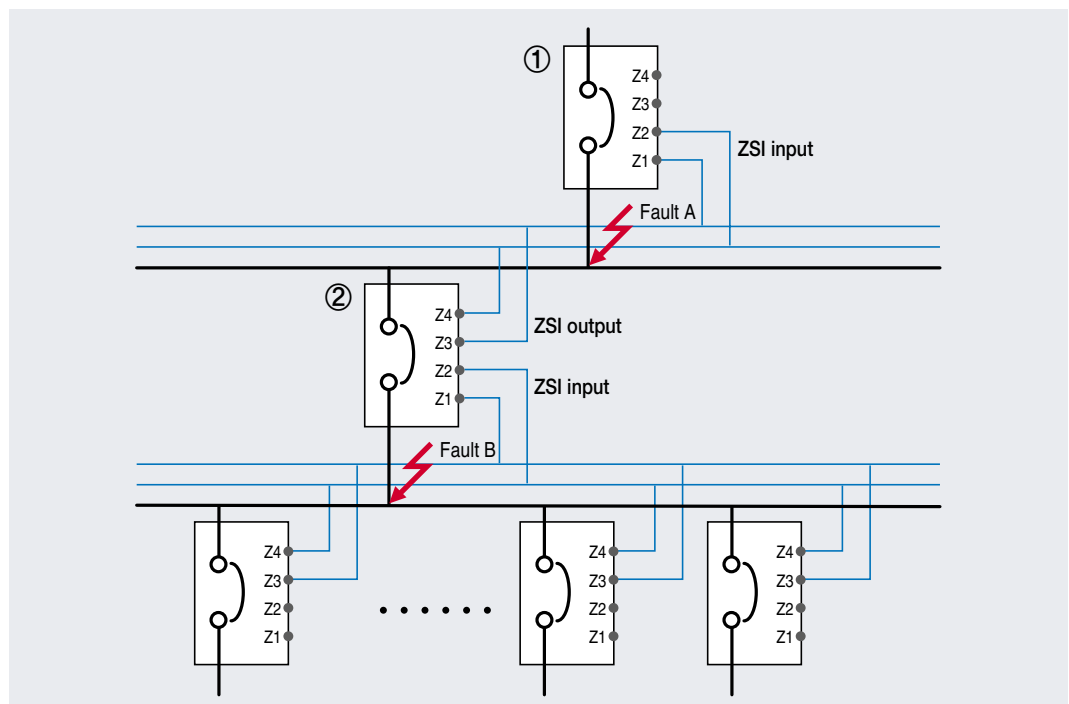

- 1) Occurrence of fault A
  - Only breaker ① performs instantaneous trip operation.
- 2) Occurrence of fault B
  - Breaker ② performs instantaneous trip operation,
  - breaker ① performs trip operation after prearranged delay time
  - But if breaker ② did not break the fault normally,
  - breaker ① performs instantaneous trip operation to protect system.

# Trip relays

Susol

## Remote reset and digital I/O (A, P, S type)

In case of that ACB operates due to accidents or over current, Trip relay indicates the information of the accident through the LED and LCD. Trip relay A, P and S type is possible to perform the remote reset by digital input, and have 3 DO(Digital output).

1. Methods to reset Trip relay is to push the Reset button on the frontal side and to use the remote reset.
2. Digital input
  - [R11-R22] input: Remote reset
  - [Z1-Z2] Input: ZSI input
  - [E1-E2] Input: ZCT for earth leakage detection or external CT input

※ All DI are dry contact that has 3.3V of recognition voltage. When inputting close by SSR(Solid State Relay) or open-collector, connect collector(Drain) to R11.
3. Digital output 3a(524, 534, 544-513)
  - Fault output: Long/Short time delay, Instantaneous, Ground fault, UVR, OVR, UFR, OFR, rPower, Vunbal, lunbal (Maintains state as Latch form until user pushes reset.)
  - Overload alarm: Above 90%
  - General DO: when setting L/R as remote, it is available to control close/open remotely by using communication.

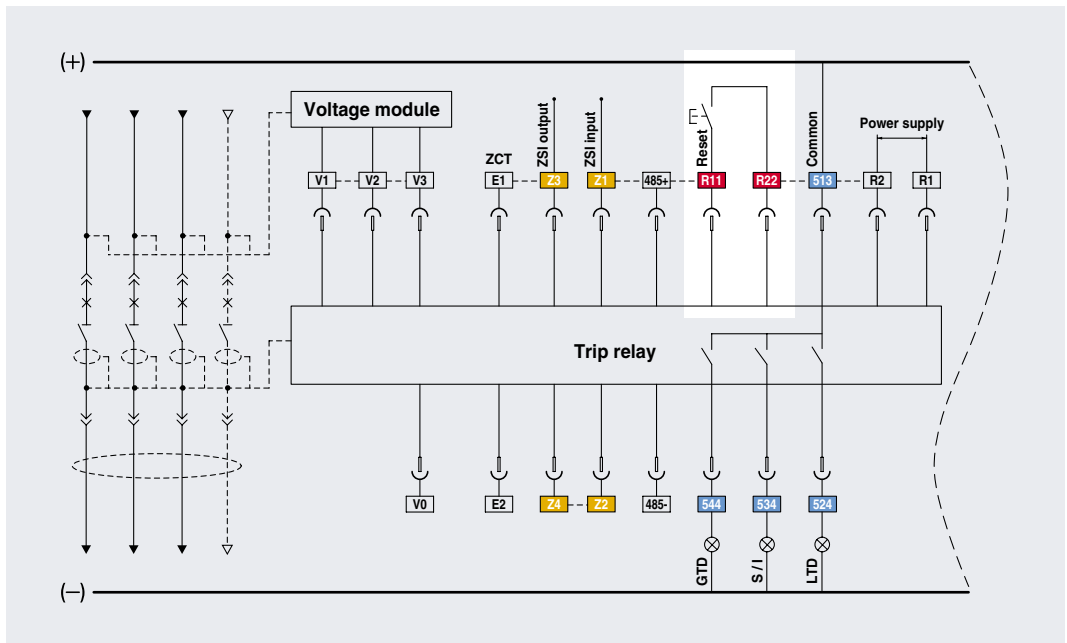

Trip relay	Digital output	Long time	Short time	Instantaneous	Ground	Overload fault	OVR alarm	UVR	rPower	Vunbal	lunbal	OFR	UFR	Note
P, S type	DO1(524)	●	○	○	○	○	○	○	○	○	○	○	○	Programmable
	DO2(534)	○	●	●	○	○	○	○	○	○	○	○	○	
	DO3(544)	○	○	○	●	○	○	○	○	○	○	○	○	
A type	DO1(524)	●	×	×	×	Not available							Fixed	
	DO2(534)	×	●	●	×									
	DO3(544)	×	×	×	●									

## Communication

### Modbus/RS-485

- Operation mode: Differential
- Distance: Max. 1.2km
- Cable :  
General RS-485 shielded twist 2-pair cable
- Baud rate :  
9600bps, 19200bps, 38400bps
- Transmission method: Half-Duplex
- Termination: 150Ω

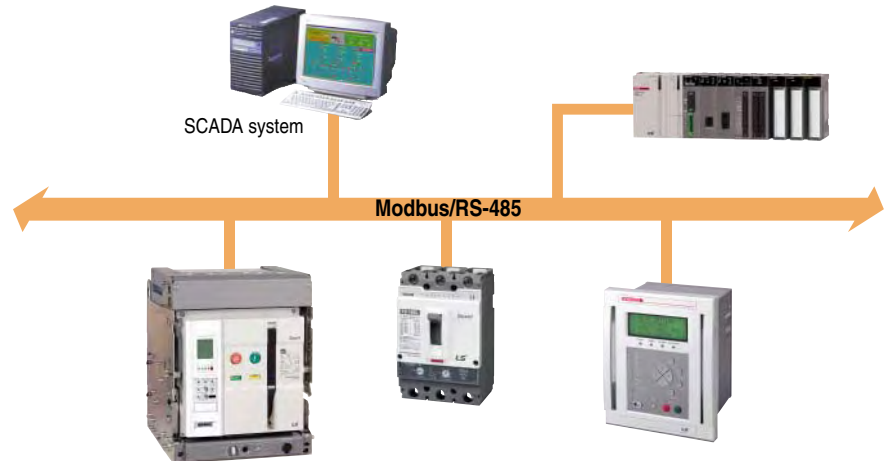

### Profibus-DP

- Profibus-DP module is installed separately (Option)
- Operation mode: Differential
- Distance: Max. 1.2km
- Cable :  
Profibus-DP shielded twist 2-pair cable
- Baud rate: 9600bps~12Mbps
- Transmission method: Half-Duplex
- Termination: 150Ω
- Standard: EN 50170 / DIN 19245



Profibus-DP communication module (Option)

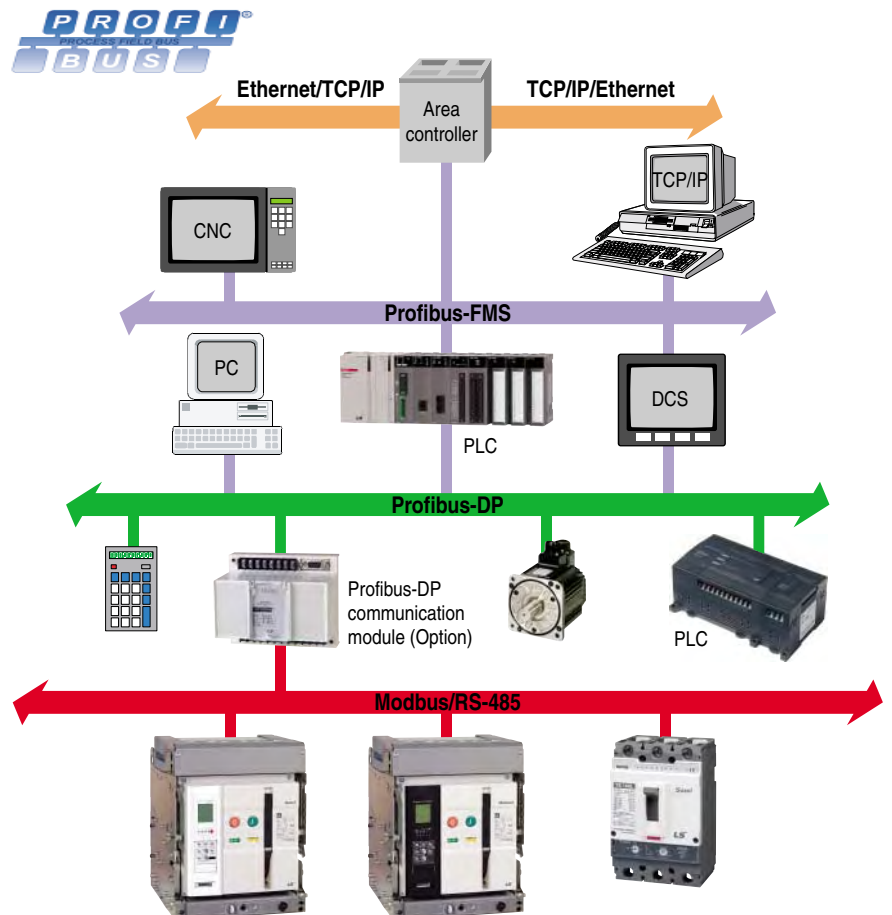

# Trip relays

Susol

## Event & fault recording (P, S type)

When there are events such as setting change, Info. change, error of self-diagnose, state change, P and S type record Max. up to 256 information of the events in accordance with time(ms). In addition, they can record Max. up to 256(up to 10 for A type) information of the faults such as fault cause, fault phase, fault value and so on in accordance with time(ms).

### Event information display

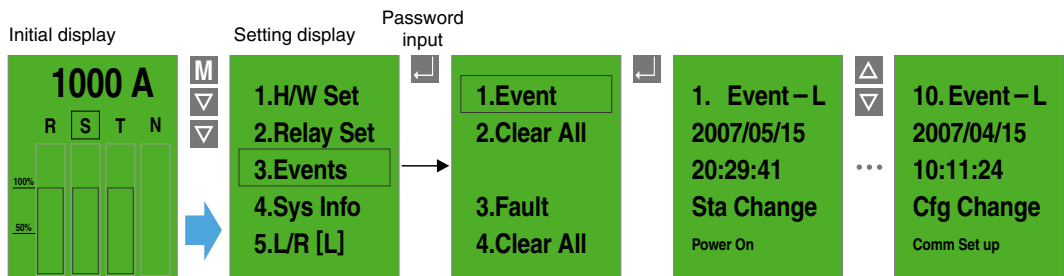

### Fault information display

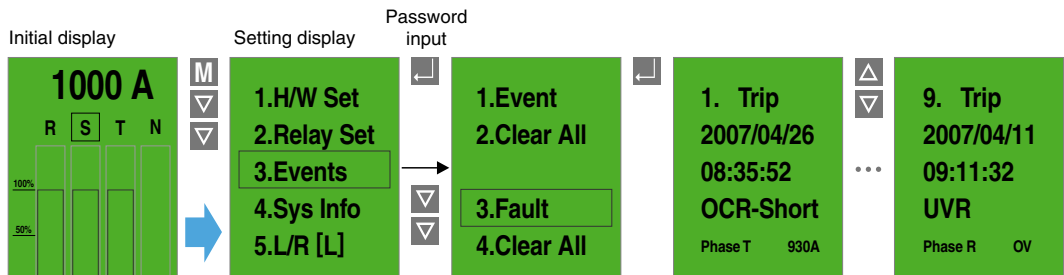

## System information

P and S type can indicate information as followings with the information of the ACB.

- Present time: year/month/date/hour/minute/ms
- ACB current ratings
- N-phase current ratings: 100%
- Frequency information: 60Hz / 50Hz
- Closing numbers of breaker: CB ON numbers
- Trip relay operating time: OCR ON time
- ON time of breaker: CB ON time
- S/W ver. information

### System information display

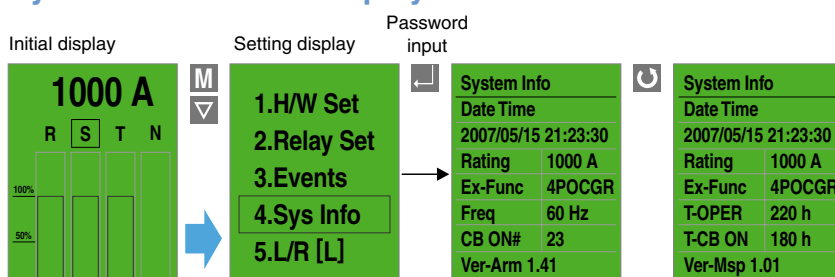



# System block diagram

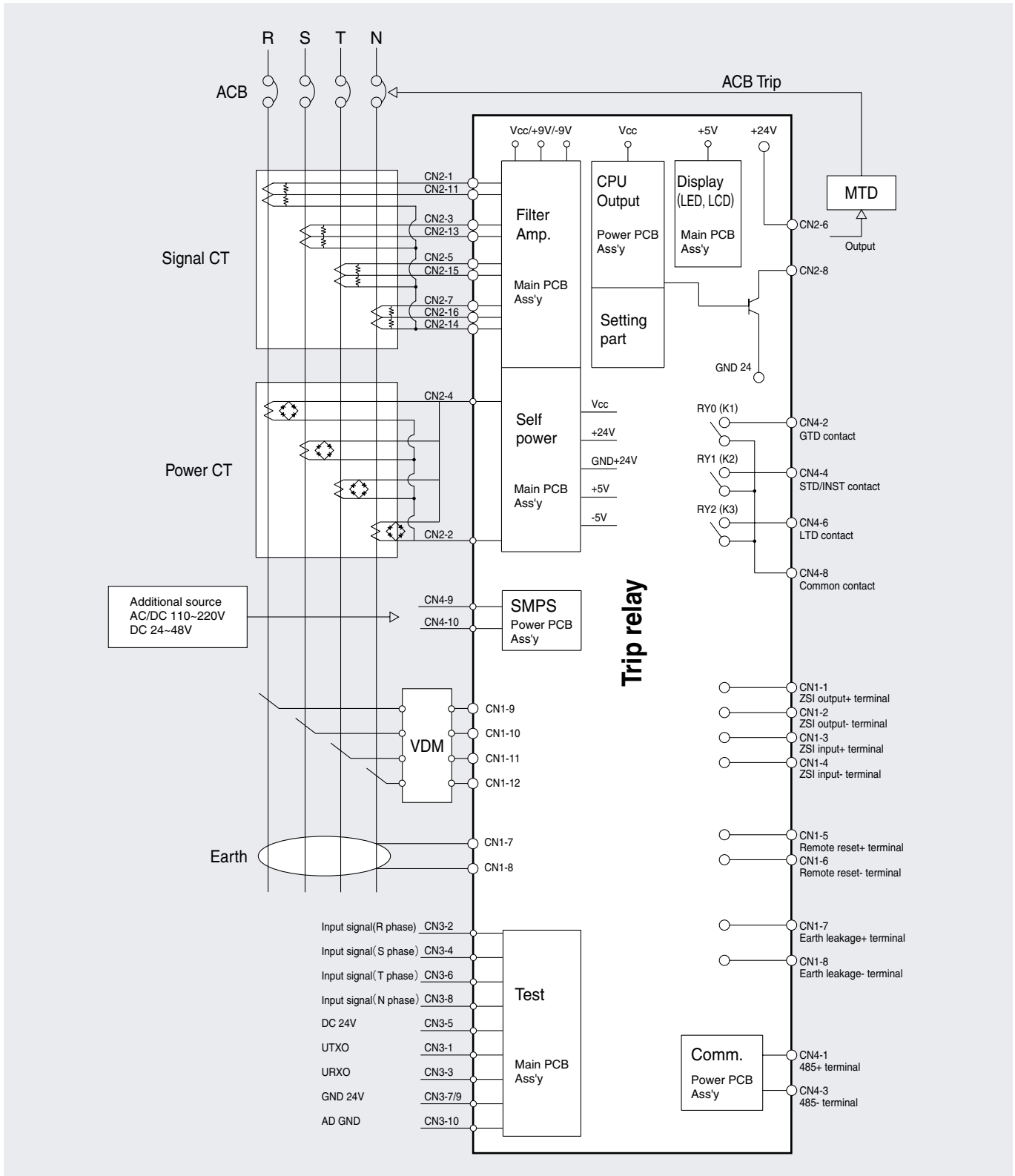

# Accessories

Susol



Mounting	Accessories		AH		AS		AN		Remark	Page
			Default	Option	Default	Option	Default	Option		
Internal	SHT1	Shunt Coil	●		●		●		*	52
	SHT2	Double Shunt Coil		○		○		○	*	53
	CC	Closing Coil	●		●		●		*	54
	M	Motor	●		●		●		*	55
	CS1	Charge Switch	●		●		●		*	55
	CS2	Charge Switch Communication		○		○		○	*	55
	UVT	Under Voltage Trip Device		○		○		○	*	56
	AL	Trip Alarm Contact		○		○		○	*	57
	MRB	Manual Reset Button		○		○		○	*	57
	RCS	Ready to Close Switch		○		○		○	*	58
	C	Counter	●			○		○	*	58
	AX	Auxiliary Switch		○		○		○	*	59
	SL	Slow Closing Lever		○		○				60
	ADM	Automatically Discharge Mechanism		○		○			*	60
	External	TM	Temperature Alarm		○		○		○	*
K1		Key Lock		○		○		○	*	61
K2		Key Interlock Set		○		○		○	*	61
K3		Double Key Lock		○		○		○	*	62
B		On/Off Button lock		○		○		○	*	62
LH		Lifting Hook		○		○		○		63
CTD		Condenser Trip Device		○		○		○		63
ATS		Automatic Transfer Switch Controller		○		○		○		64
DC		Dust Cover		○		○		○		65
OT		OCR Tester		○		○		○		66
J		Manual Connector		○	●		●		*	
A		Automatic Connector	●			○		○	*	

\* Separate purchasing is not allowed. Each item should be purchased with the main body.



Mounting	Accessories		AH		AS		AN		Remark	Page
			Default	Option	Default	Option	Default	Option		
Trip relay	N	N type		<input type="radio"/>		<input type="radio"/>		<input type="radio"/>	*	28
	A	A type		<input type="radio"/>		<input type="radio"/>		<input type="radio"/>	*	30
	P	P type		<input type="radio"/>		<input type="radio"/>		<input type="radio"/>	*	32
	S	S type		<input type="radio"/>					*	34
	ZCT	ZCT for the earth leakage		<input type="radio"/>		<input type="radio"/>		<input type="radio"/>		
Cradle	SBC	Shorting "b" Contact		<input type="radio"/>		<input type="radio"/>		<input type="radio"/>		67
	MI	Mechanical Interlock		<input type="radio"/>		<input type="radio"/>		<input type="radio"/>		67
	ST	Safety Shutter		<input type="radio"/>		<input type="radio"/>		<input type="radio"/>	*	68
	STL	Safety Shutter Lock		<input type="radio"/>		<input type="radio"/>		<input type="radio"/>		68
	DF	Door Frame		<input type="radio"/>		<input type="radio"/>		<input type="radio"/>		69
	MIP	Miss Insertion Prevent Device		<input type="radio"/>		<input type="radio"/>		<input type="radio"/>		74
	MOC	Mechanical Operated Cell Switch		<input type="radio"/>		<input type="radio"/>		<input type="radio"/>		65
	CEL	Cell Switch		<input type="radio"/>		<input type="radio"/>		<input type="radio"/>		70
	DI	Door Interlock		<input type="radio"/>		<input type="radio"/>		<input type="radio"/>		71
	ZAS	Zero Arc Space	●			<input type="radio"/>			*	71
	SC	Safety Control Cover	●			<input type="radio"/>		<input type="radio"/>	*	72
	CMB	Cradle Mounting Block		<input type="radio"/>		<input type="radio"/>		<input type="radio"/>	*	72
	RI	Racking Interlock		<input type="radio"/>		<input type="radio"/>		<input type="radio"/>		73
	PL	Pad Lock/ Position Lock	●		●		●		*	73
	IB	Insulation Barrier	●			<input type="radio"/>		<input type="radio"/>	*	69
	UDC	UVT Time Delay Controller		<input type="radio"/>		<input type="radio"/>		<input type="radio"/>		75
	ADP	Compatible Adapter		<input type="radio"/>		<input type="radio"/>		<input type="radio"/>		
Other	RPH	Reverse Phase ACB		<input type="radio"/>		<input type="radio"/>		<input type="radio"/>		
	DUM	Dummy ACB		<input type="radio"/>		<input type="radio"/>		<input type="radio"/>		
	VAD	Various Connection Type		<input type="radio"/>		<input type="radio"/>		<input type="radio"/>		
	RCO	Remote I/O		<input type="radio"/>		<input type="radio"/>		<input type="radio"/>		77
	PC	Profibus-DP comm. module		<input type="radio"/>		<input type="radio"/>		<input type="radio"/>		

\* Seperate purchasing is not allowed. Each item should be purchased with the main body.

# Accessories

Susol

## Shunt Coil [SHT1]

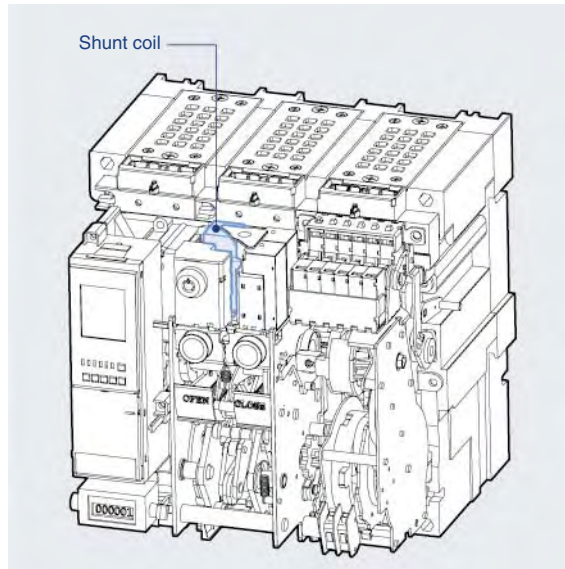

- It is a control device which trips a circuit breaker from remote place, when applying voltage continuously or instantaneously over 200ms to coil terminals(C1, C2).
- When UVT coil is installed, its location is changed.

### 1. Rated voltage and characteristics of Trip coil

Rated voltage [Vn]		Operating voltage range [V]	Power consumption (VA or W)		Trip time [ms]
DC [V]	AC [V]		Inrush	Steady-state	
24~30	-	0.6~1.1 Vn	200	5	Less than 40ms
48~60	48	0.6~1.1 Vn			
100~130	100~130	0.56~1.1 Vn			
200~250	200~250	0.56~1.1 Vn			
-	380~480	0.56~1.1 Vn			

Note) Operating voltage range is the min. rated voltage standard for each rated voltage(Vn).

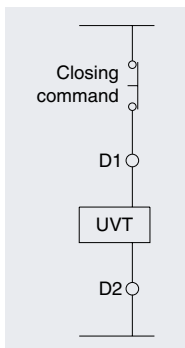

Wiring Diagram

### 2. Specification of the wire

- Refer to the below table regarding the length and specification of wire when using trip coil with DC 24~30[V] or DC/AC 48~60[V] of rated voltage.

The maximum wire length

		Rated voltage [Vn]			
		DC 24~30 [V]		DC/AC 48 [V]	
Wire type		#14 AWG (2.08mm <sup>2</sup> )	#16 AWG (1.31mm <sup>2</sup> )	#14 AWG (2.08mm <sup>2</sup> )	#16 AWG (1.31mm <sup>2</sup> )
Operating voltage	100%	95.7m	61m	457.8m	287.7m
	85%	62.5m	38.4m	291.7m	183.2m

## Double Shunt Coil [SHT2]

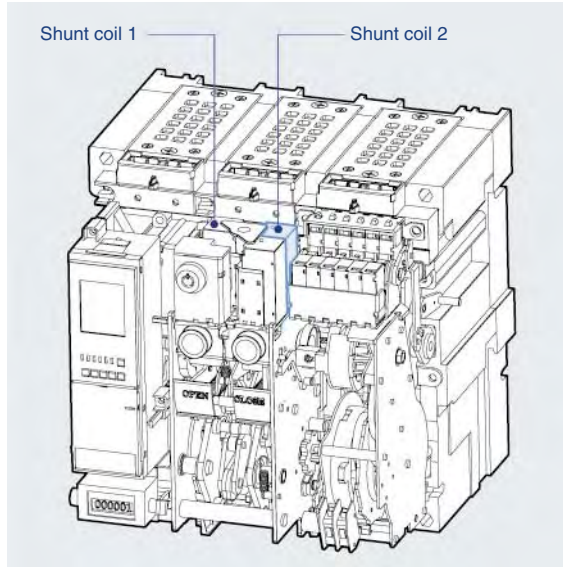

- It is a control device which trips a circuit breaker doubly from the outside. When SHT1 doesn't operate normally, it can trip a circuit breaker safely.
- Shunt coil 1: Install it at existing location.
- Shunt coil 2: Install it on the right side of the Shunt coil 1
- It is not available with UVT coil when installing double shunt coil.

### 1. Rated voltage and characteristics of Trip coil

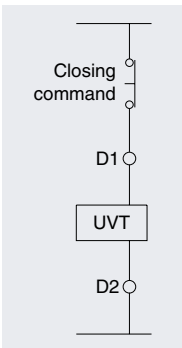

Wiring Diagram

Rated voltage [Vn]		Operating voltage range [V]	Power consumption (VA or W)		Trip time [ms]
DC [V]	AC [V]		Inrush	Steady-state	
24~30	-	0.6~1.1 Vn	200	5	Less than 40ms
48~60	48	0.6~1.1 Vn			
100~130	100~130	0.56~1.1 Vn			
200~250	200~250	0.56~1.1 Vn			
-	380~480	0.56~1.1 Vn			

Note) Operating voltage range is the min. rated voltage standard for each rated voltage(Vn).

### 2. Specification of the wire

- Refer to the below table regarding the length and specification of wire when using trip coil with DC 24~30[V] or DC/AC 48~60[V] of rated voltage.

The maximum wire length

Wire type		Rated voltage [Vn]			
		DC 24~30 [V]		DC/AC 48 [V]	
		#14 AWG (2.08mm <sup>2</sup> )	#16 AWG (1.31mm <sup>2</sup> )	#14 AWG (2.08mm <sup>2</sup> )	#16 AWG (1.31mm <sup>2</sup> )
Operating voltage	100%	95.7m	61m	457.8m	287.7m
	85%	62.5m	38.4m	291.7m	183.2m

# Accessories

Susol

## Closing Coil [CC]

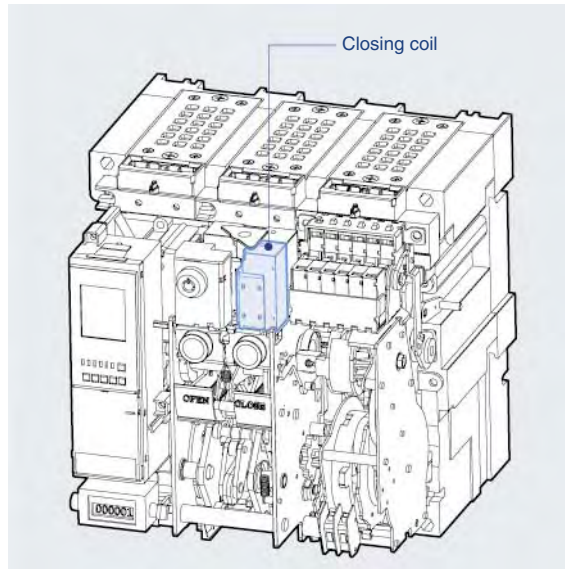

- It is a control device which closes a circuit breaker, when the voltage is applied continuously or instantaneously over 200ms to the coil terminals (C1, C2).

### 1. Rated voltage and characteristics of Closing coil

Rated voltage [Vn]		Operating voltage range [V]	Power consumption (VA or W)		Shunt time [ms]
DC [V]	AC [V]		Inrush	Steady-state	
24~30	-	0.75~1.1 Vn	200	5	Less than 65ms
48~60	48	0.75~1.1 Vn			
100~130	100~130	0.75~1.1 Vn			
200~250	200~250	0.75~1.1 Vn			
-	380~480	0.75~1.1 Vn			

Note) Operating voltage range is the min. rated standard for each rated voltage (Vn).

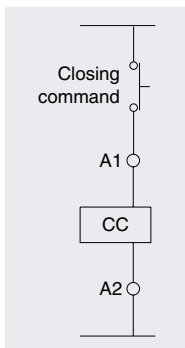

Wiring Diagram

### 2. Specification of the wire

- Refer to the below table regarding the length and specification of wire when using trip coil with DC 24~30[V] or DC/AC 48~60[V] of rated voltage.

The maximum wire length

		Rated voltage [Vn]			
		DC 24~30 [V]		DC/AC 48 [V]	
Wire type		#14 AWG (2.08mm <sup>2</sup> )	#16 AWG (1.31mm <sup>2</sup> )	#14 AWG (2.08mm <sup>2</sup> )	#16 AWG (1.31mm <sup>2</sup> )
Operating voltage	100%	95.7m	61m	457.8m	287.7m
	85%	62.5m	38.4m	291.7m	183.2m

## Motor [M]

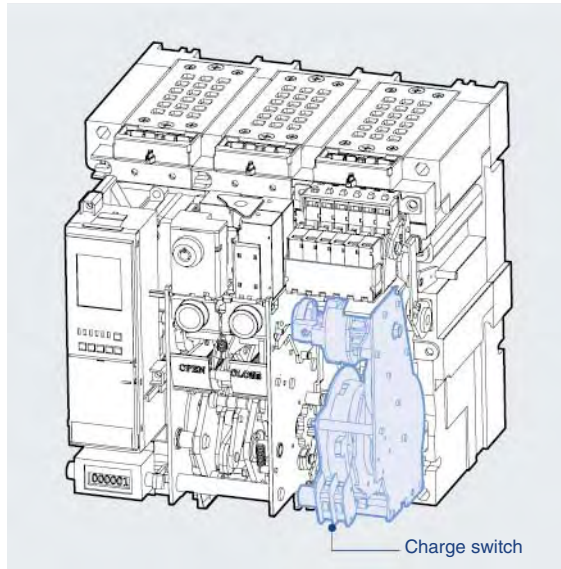
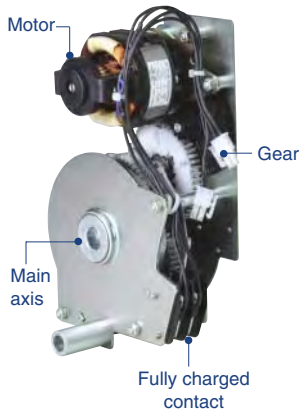

- Charge the closing spring of a circuit breaker by the external power source. Without the external power source, charge manually.
- Operating voltage range(IEC 60947) 85%~110%Vn

Input voltage(V)	DC 24~30V	AC/DC 48~60V	AC/DC 100~130V	AC/DC 200~250V	AC 380V	AC 440~480V
Load current(max.)	5A	3A	1A	0.5A	0.3A	0.3A
Starting current(Max.)	5 times of load current					
Load rpm(Motor)	15000 ~ 19000 rpm					
Charge time	Less than 5sec.					
Dielectric strength	2kV/min					
Using temperature range	-20° ~ 60°					
Using humidity range	Max. RH 80% (No dew condensation)					
Endurance	15,000 cycle (Load connection, 2 times/min)					
Charge switch	10A at 250VAC					

## Charge Switch [CS1]

## Charge Switch Communication [CS2]

- It is a built-in contact which sends the signal to the outside, when motor charging is completed. (2a)
- It has a “1a” contact for communication and the other “1a” contact for complete charging.
- When using an extra communication module (Remote I/O), the state of contacts can be displayed through the network.
- 10A at 250VAC

# Accessories

Susol

## Under Voltage Trip device [UVT]

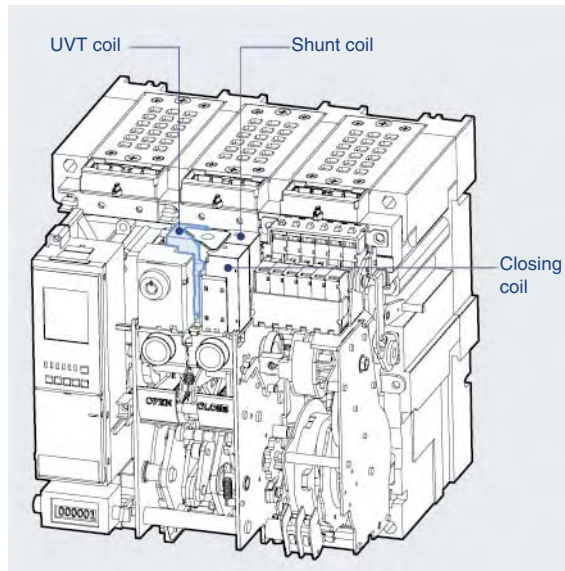

- If the voltage of the main or the control power is under voltage, UVT which is installed inside of the breaker breaks the circuit automatically. Please connect with UVT time-delay device in order to present the time-delay function because UVT is technically instantaneous type.
- The closing of a circuit breaker is impossible mechanically or electrically if control power not supplied to UVT. To close the circuit breaker, 65~85% of rated voltage should be applied to both terminals of UVT coil (D1, D2).
- When using UVT coil, the double trip coil can not be used, and the location of trip coil is changed.

### 1. Rated voltage and characteristics of UVT coil

Rated voltage [Vn]		Operating voltage range [V]		Power consumption (VA or W)		Trip time [ms]
DC [V]	AC [V]	Pick up	Drop out	Inrush	Steady-state	
24~30	-	0.65~0.85 Vn	0.4~0.6 Vn	200	5	Less than 50ms
48~60	48					
100~130	100~130					
200~250	200~250					
-	380~480					

Note) Operating voltage range is the min. rated standard for each rated voltage (Vh).

### 2. Specification of the wire

- Refer to the below table regarding the length and specification of wire when using trip coil with DC 24~30[V] or DC/AC 48~60[V] of rated voltage.

The maximum wire length

		Rated voltage [Vn]			
		DC 24~30 [V]		DC/AC 48 [V]	
Wire type		#14 AWG (2.08mm <sup>2</sup> )	#16 AWG (1.31mm <sup>2</sup> )	#14 AWG (2.08mm <sup>2</sup> )	#16 AWG (1.31mm <sup>2</sup> )
Operating voltage	100%	48.5m	30.5m	233.2m	143.9m
	85%	13.4m	8.8m	62.5m	39.3m

Note) In case of using UVT coil, the location of TC coil is changed.



## Trip Alarm Contact [AL]

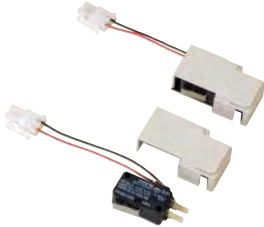

- When a circuit breaker is tripped by OCR which operates against the faulty current (Over Current Relay), Trip Alarm switch provides the information regarding the trip of circuit breaker by sending the electrical signal from the mechanical indicator on main cover of main circuit breaker or internal auxiliary switch. (Installed at the inside of circuit breaker)
- When a circuit breaker tripped by faulty current, a mechanical trip indicator (MRB, Manual Reset Button) pops out from the main cover and the switch (SDE) which sends control signal electrically is conducted to output the information occurred from faulty circuit breaker.
- MRB and AL can be operated only when tripping by OCR, but doesn't be operated by Off button and OFF operation of trip coil.
- To re-close a circuit breaker after a trip, press MRB to reset it for closing.
- 2pcs of electrical trip switch (AL1, AL2, 1a) are provided (Option)
- Trip alarm contact and MRB(Manual reset bottom) need to be purchased together.

### 1. Electrical characteristics of trip alarm contact

Rated voltage [V]	Non-inductive load (A)		Inductive load (A)		Inrush current
	Resistive load	lamp load	Inductive load(A)	Motor load	
8V DC	11	3	6	3	MAX. 24A
30V DC	10	3	6	3	
125V DC	0.6	0.1	0.6	0.1	
250V DC	0.3	0.05	0.3	0.05	
250V AC	11	1.5	6	2	

## Manual Reset Button [MRB]

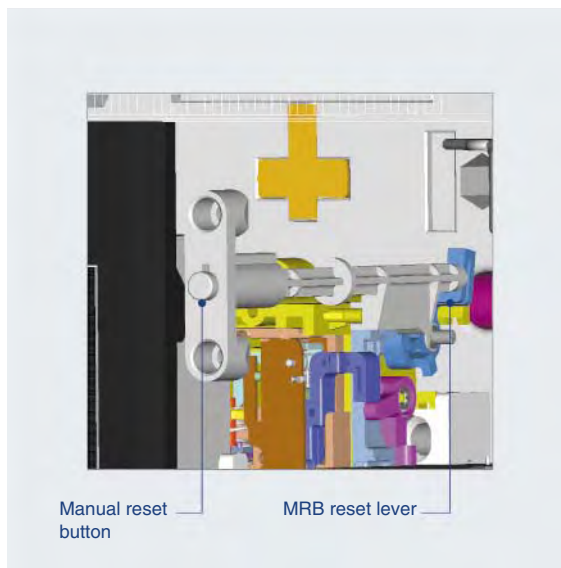
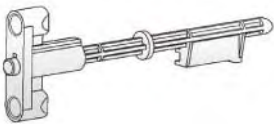

- It is a function which resets a circuit breaker manually when a circuit breaker is tripped by OCR.
- When a circuit breaker tripped by faulty current, a mechanical trip indicator (MRB, Manual Reset Button) pops out from the main cover and the switch(SDE) which sends control signal electrically is conducted to output the information occurred from faulty circuit breaker.
- MRB can be operated only by OCR but not by OFF operation of circuit breaker. To re-close a circuit breaker after a trip, press MRB to reset it for closing.

# Accessories

Susol

## Ready to Close Switch [RCS]

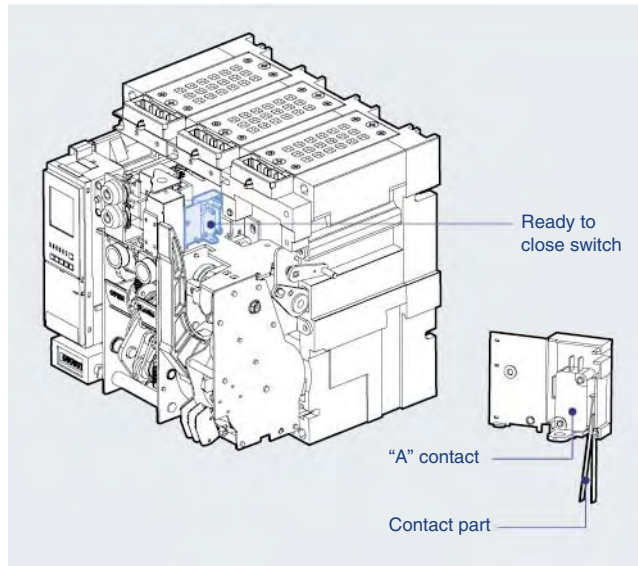

- It interlocks with mechanism of circuit breaker.
- It indicates the status that the circuit breaker is ready to do closing operation.
- When mechanism is in OFF position or in Charge, contact is output with "ON" and it indicates that mechanism can be closed.

## Counter [C]

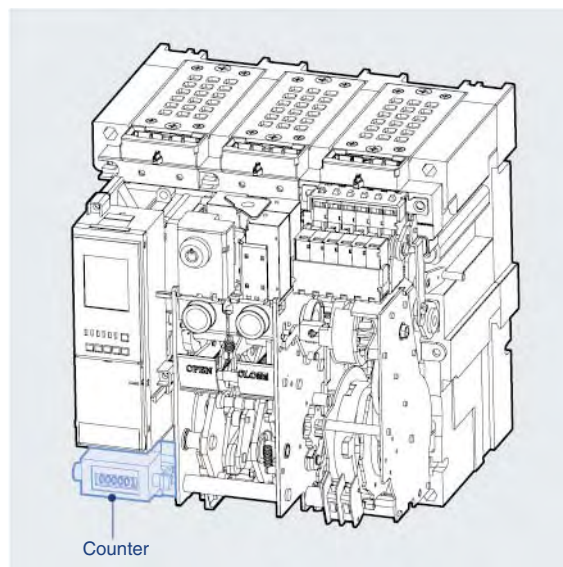

- It displays the total number of ON/OFF operation of ACB.

## Auxiliary switch [AX]

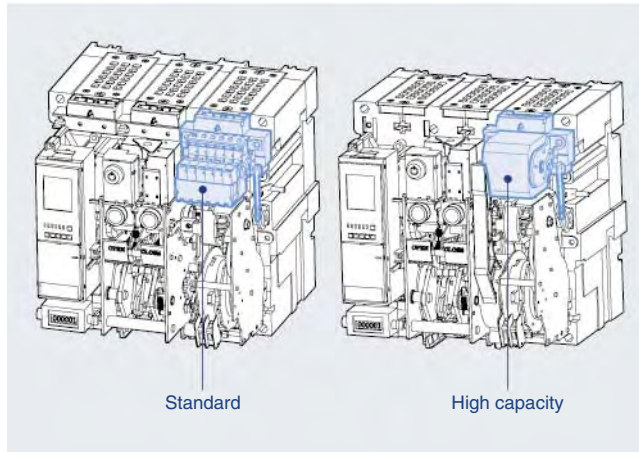
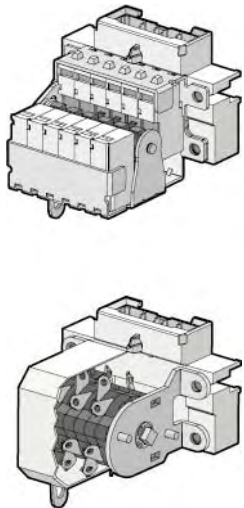

- It is a contact used to monitor ON/OFF position of ACB from remote place.

AUX. contact & charging types	
AX	Standard OFF charge 3a3b
AC	Standard ON charge 3a3b
BX	Standard OFF charge 5a5b
BC	Standard ON charge 5a5b
HX	High capacity OFF charge 5a5b
HC	High capacity ON charge 5a5b
CC	Standard ON charge 6a6b
JC	High capacity ON Charge 6a6b

### Standard classification

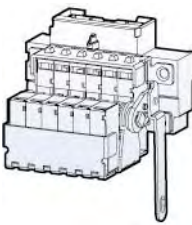
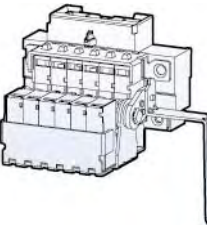
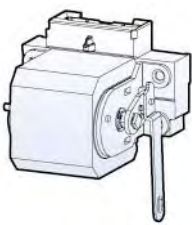
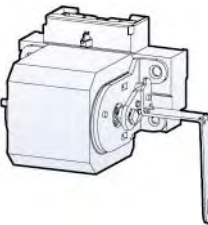
Standard		High capacity	
2000, 5000AF	4000, 6300AF	2000, 5000AF	4000, 6300AF
			

Classification		Standard			High capacity		Remark
		Resistive load	Inductive load	Resistive load	Inductive load		
Contact capacity	AC	490V	5A	6A	5A	2.5A	
		250V	10A	6A	10A	10A	
		125V	10A	6A	10A	10A	
	DC	250V	0.3A	0.3A	3A	1.5A	
		125V	0.5A	0.6A	10A	6A	
	30V	10A	6A	10A	10A		
No. of Contact that can be used	AX	3a3b		-		Standard charging type	
	BX	5a5b		-			
	HX	-		5a5b			
	AC	3a3b		-		Rapid auto-reclosing charging type	
	BC	5a5b		-			
	CC	6a6b		-			
	HC	-		5a5b			
JC	-		6a6b				

# Accessories

Susol

## Slow Closing Lever [SL]

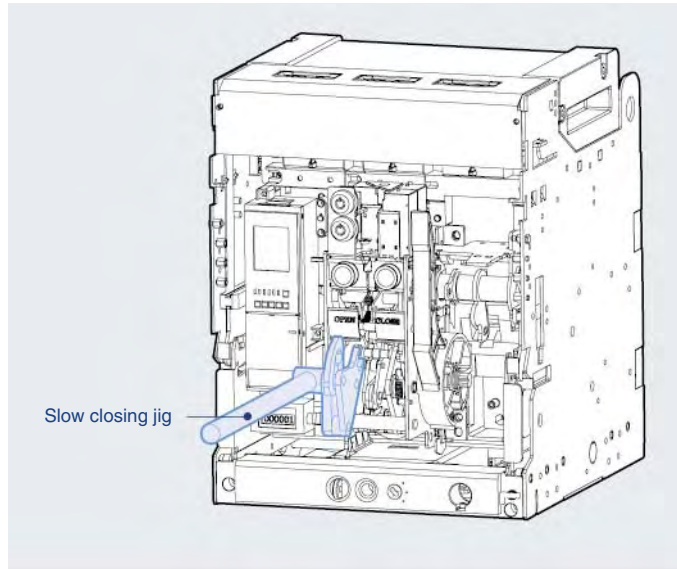
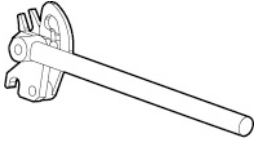

- It is the Jig which makes it possible to check the contacting status between arc contact and main contact visually by slowing down the operating speed of them when closing under fully charged condition.

## Automatic Discharge Mechanism [ADM]

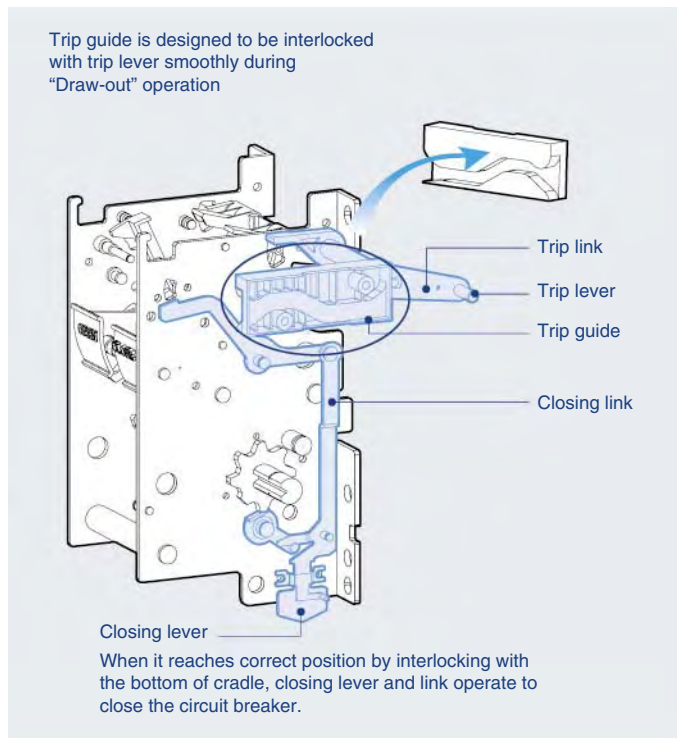
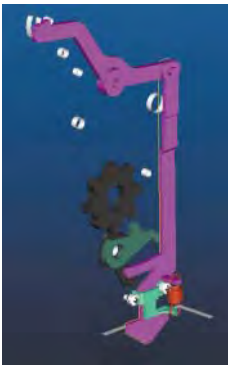

- If a circuit breaker is put into service and mechanism is in "charged" or "closed" position, safety device is required during draw-in/out operation to ensure the safety in advance.
- Drawing-out operation under "charged" position of circuit breaker → Closing and trip operation occurred in series
- Drawing-out operation out under "closed" position of circuit breaker → Trip operation

## Key Lock [K1]

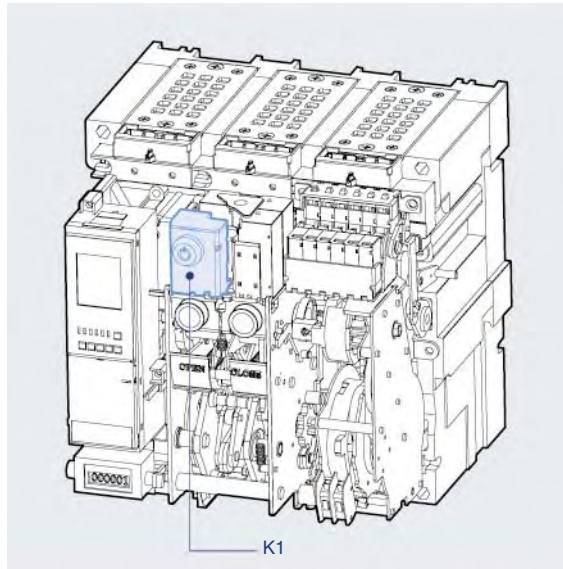

- It is a device for locking which prevents a certain circuit breaker from being operated by user's discretion when two or more circuit breakers are used at the same time.
- K1: Preventing mechanical closing

## Key Interlock Set [K2]

### Wiring

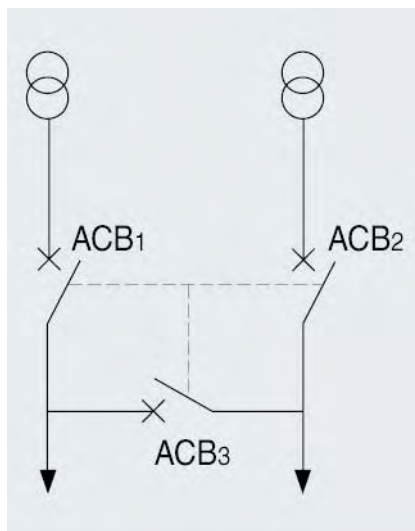

- 3 circuit breakers can be arranged for the continuous power supply to the load side and be interlocked mutually by using Key Lock embedded in each circuit breaker.

ACB-1	ACB-2	ACB-3	Status	
			LOAD1	LOAD2
●	●	●	OFF	OFF
●	○	○	OFF	ON
○	●	○	ON	OFF
○	○	●	ON	ON
●	●	○	OFF	OFF
●	○	●	OFF	ON
○	●	●	ON	OFF

○: Release ●: Lock

# Accessories

Susol

## Double Key Lock [K3]

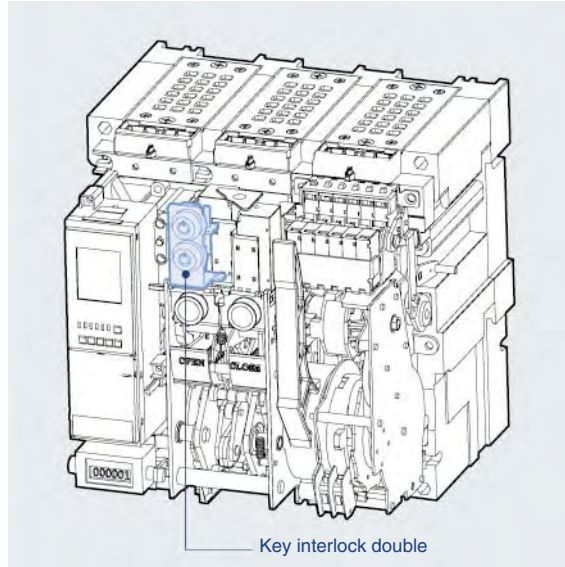

- When only two keys are released at the same time, circuit breakers operate. Handling method is same as K1.

## ON/OFF Button Lock [B]

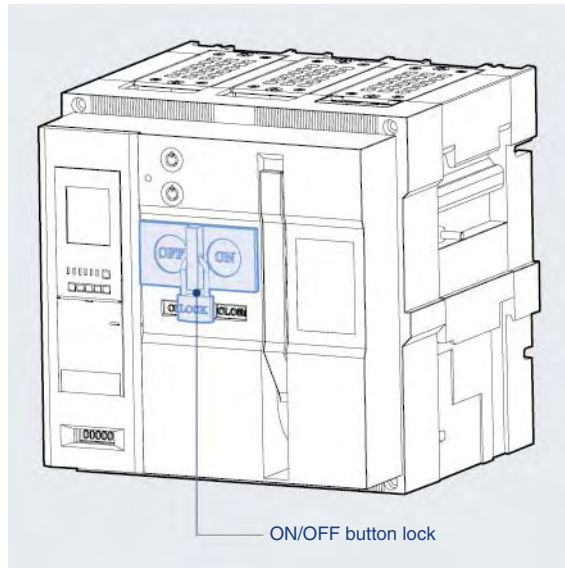

- It is to prevent manual operation of ACB's closing/tripping button due to user's wrong handling.
- It is not possible to handle ON/OFF operation under the "Button lock" status.

## Lifting Hook [LH]

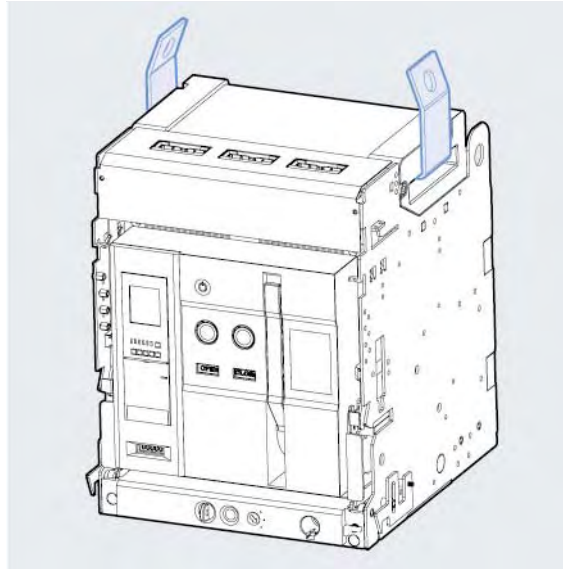

- It is a device to make an ACB easy to shift.
- Please hang it to both handles of the arc cover.

## Condenser Trip Device [CTD]



- It gets a circuit breaker tripped electrically within regular time when control power supply is broken down and is used with Shunt coil, SHT. In case there is no DC power, It can be used as the rectifier which supplies DC power to a circuit breaker by rectifying AC power.

### Ratings

Ratings	Specification	
Model	CTD-100	CTD-200
Rated input voltage (V)	AC 100/110	AC 200/220
Frequency (Hz)	50/60	50/60
Rated charge voltage (V)	140/155	280/310
Charging time	Within 5S	Within 5S
Trip possible time	Over 3 MIN	Over 2 MIN
Range of Input voltage (%)	85~110	85~111
Condenser capacity	400 $\mu$ F	160 $\mu$ F

### External dimension

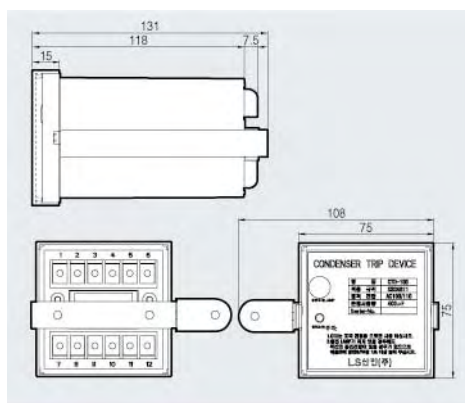

### Circuit diagram

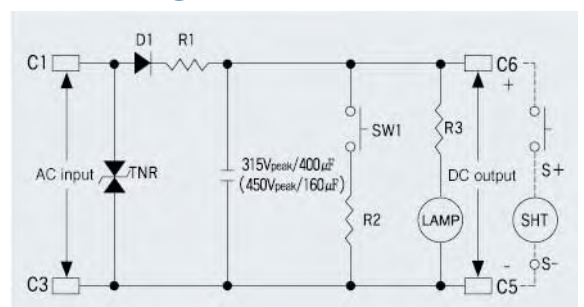

## Automatic Transfer Switch Controller [ATS]



### Ratings

Model type	ATSC-110	ATSC-110-C	ATSC-220	ATSC-220-C
Rated voltage	AC 110V		AC 220V	
Voltage range	AC 93.5(±5%) ~ 126.5V(±5%)		AC 187(±5%) ~ 253V(±5%)	
Frequency	50Hz/60Hz			
Power consumption (apparent power)	15.4W			
4-location switch (stop, N, R, Auto)	■	■	■	■
Test function	■	■	■	■
Generator control function	■	■	■	■
NRS function	■	■	■	■
N power source setting (phase-to-phase/ 3phases)	■	■	■	■
Time setting (T1~T6)	■	■	■	■
Fault function (OCR/Circuit breaker trouble)	■	■	■	■
Output contact (Auto, Load burden)	■	■	■	■
Communication function (RS-485)	-	■	-	■

- T<sub>1</sub>: The delayed time from when UN (power supply of electric company) is tripped to when generator start-up signal contact is closed. (t<sub>1</sub>: 0.1, 0.5, 1, 2, 4, 8, 15, 30, 40, 50secs)
- T<sub>2</sub>: The delayed time from when UN is closed to when ACB<sub>2</sub> is tripped. (t<sub>2</sub>: 0.1, 1, 2, 4, 8, 15, 30, 60, 120, 240secs)
- T<sub>3</sub>: The delayed time from when ACB<sub>1</sub> is tripped to when ACB<sub>2</sub> is closed. (t<sub>3</sub>: 0.5, 1, 2, 5, 10, 15, 20, 25, 30, 40secs)
- T<sub>4</sub>: The delayed time from when ACB<sub>2</sub> is tripped to when ACB<sub>1</sub> is closed. (t<sub>4</sub>: 0.5, 1, 2, 5, 10, 15, 20, 25, 30, 40secs)
- T<sub>5</sub>: The delayed time when ACB<sub>1</sub> is closed to when generator start-up signal contact is opened. (t<sub>5</sub>: 60, 120, 180, 240, 300, 360, 420, 480, 540, 600secs)
- Stop-mode: This mode is for compulsory trip of ACB<sub>1</sub>(electric power company) or ACB<sub>2</sub> (power station) when UN (power supply of electric power company) or UR (power supply of power station) is available  
\*UN or UR should be kept in ON position
- N-mode: This mode is for compulsory closing of ACB<sub>1</sub> when UN is available.  
\* it does not matter to be ON or OFF position of UR and if converting to N-mode while using UR, generator start-up signal contact is opened.
- R-mode: This mode is for compulsory closing of ACB<sub>2</sub> during the use of UR regardless of that UN is available or not.
- Auto-mode: This mode is for transferring a circuit breaker automatically to available power supply of UN or UR. In short, it trips the circuit breaker where power supply is not available and it close the circuit breaker where power supply is available.



## Dust Cover [DC]

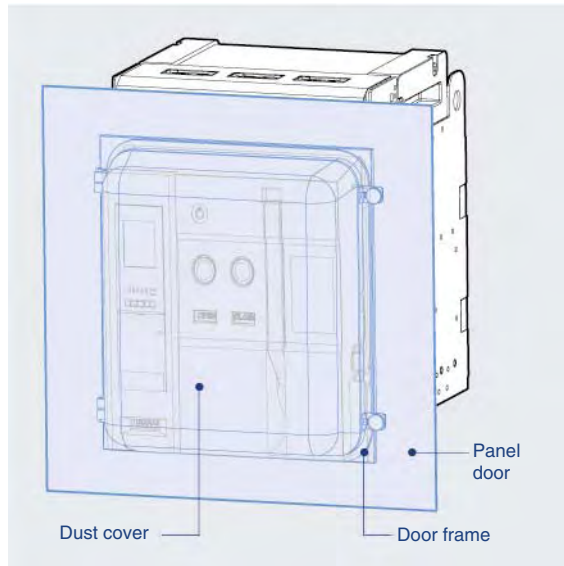

- Attach it to the door frame.
- It protects the product against the dust (IP5X) which may cause faulty operation and enhances the sealing degree by being mounted to protrude type of panel.
- It is transparent so that the front side of ACB is visible and the Cover can be opened/closed even if ACB is drawn out to until TEST position.

## Mechanical Operated Cell Switch [MOC]

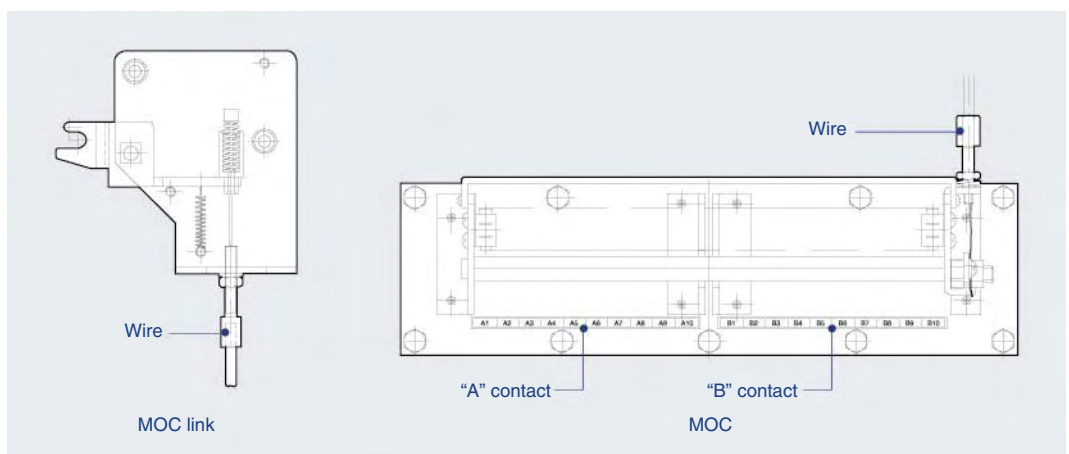
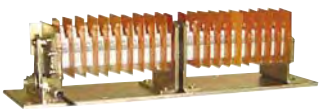

- It is the contact (10a10b) which displays the ON/OFF condition of ACB. It mechanically operates only when the breaker is "CONNECTED" position. A standard type and a high capacity type is available.
- The contact capacity is as same as the ratings of aux. contacts.
- When MOC link is installed to cradle, MOC can be equipped with the inside of panel.

# Accessories

Susol

## OCR Tester [OT]

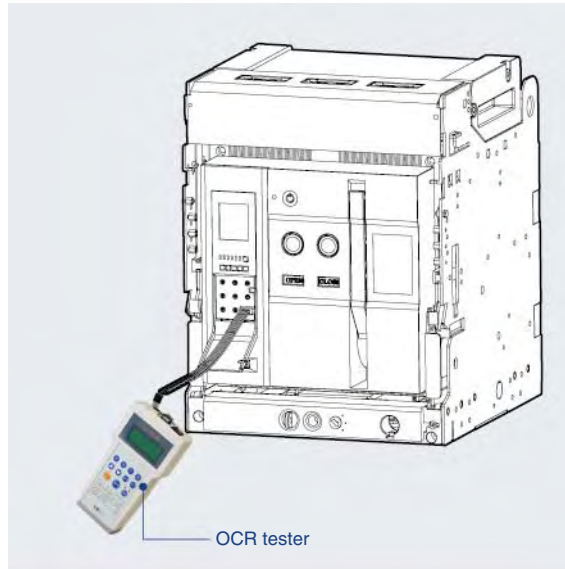

- It is a device which can test for the operation of Trip Relay under no power condition.

1. Maximum 17 times rated current can be inputted.
2. It is possible to enter the current value and phase on each of R/S/T/N
3. Frequency is adjustable.
4. It is available to test for long time delay/short time delay/instantaneous /ground fault.

## Configuration



R S T N	R, S, T, N phase signal input
▲ ▼	Increase/Decrease signal input
SET DEL	Signal setting/Delete
GEN STOP	Waveform generation/Stop
50Hz 60Hz Hz	Select frequency

## Shorting “b” Contact [SBC]

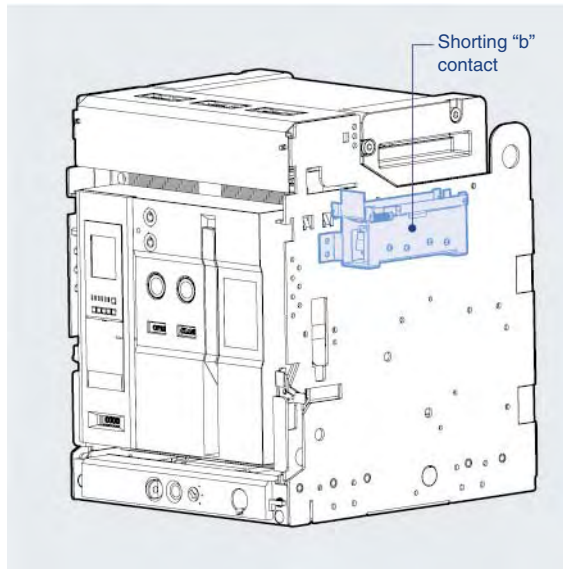
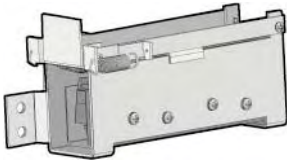

- It is the contact which keeps the external control circuit in normal by Aux. contact which disconnects “Axb” when ACB is moved from CONNECTED position to TEST position. The number of “shorting b-contact” corresponds to the number of “Axb” (4b)

### Contact condition (Link between Axb and shorting “b” contact)

ACB location		ACB condition	
		CLOSE	OPEN
Shorting “b” contact	CONNECTED location	OFF	OFF
	TEST location	ON	ON
Auxiliary contact (Axb)	CONNECTED location	OFF	ON
	TEST location	OFF	ON

## Mechanical Interlock [MI]



- It interlocks two or three circuit breakers mechanically by controlling close and trip operation mutually. It is used for distribution panel or protecting device.
- It is available to interlock with up to three ACBs by wiring connection.



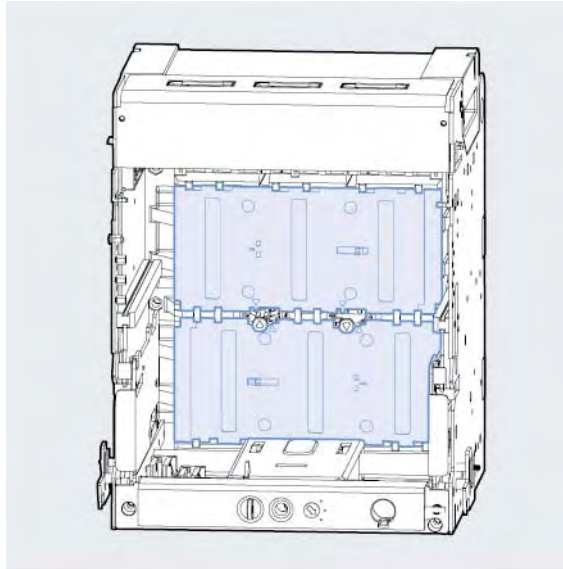

# Accessories

Susol

## Safety Shutter [ST]

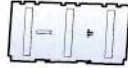

- It is the automatic safety device to protect the connectors of main circuit by cutting off dangerous contact from outside while the breaker is drawn out. When the ACB is drawn in, the shutter is automatically opened.
- There are 4 types of Safety Shutter and they are divided as shown in figure below.

The types of safety shutter plate	
2000/5000AF, 3P	4000/6300AF, 3P
	
2000/5000AF, 4P	4000/6300AF, 4P
	

## Safety Shutter Lock [STL]

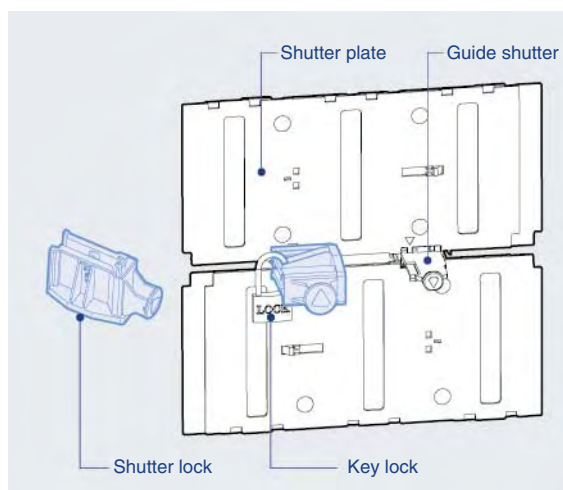

- It is a locking device which prevents safety shutter from being opened when it is closed.  
→ If shutter lock is connected with guide shutter, the guide shutter can not be pushed structurally. Thus, it is not available to open the safety shutter.

## Door Frame [DF]

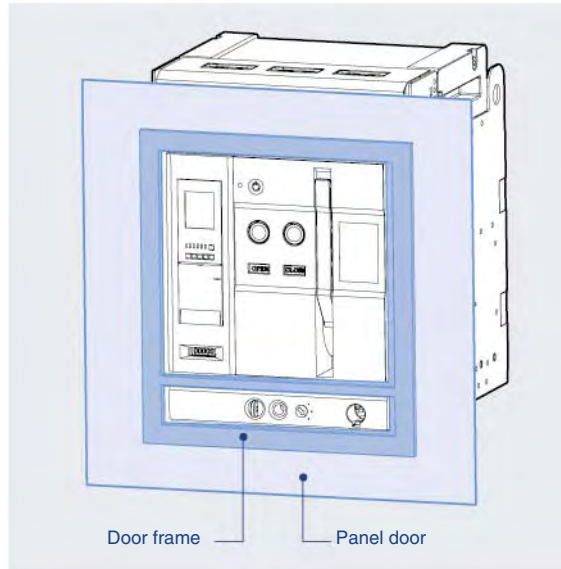

- When structuring the embedded type of ACB panel, it protects the protrude front of ACB and the cutting side of panel door by attaching it to the panel door.

## Insulation Barrier [IB]

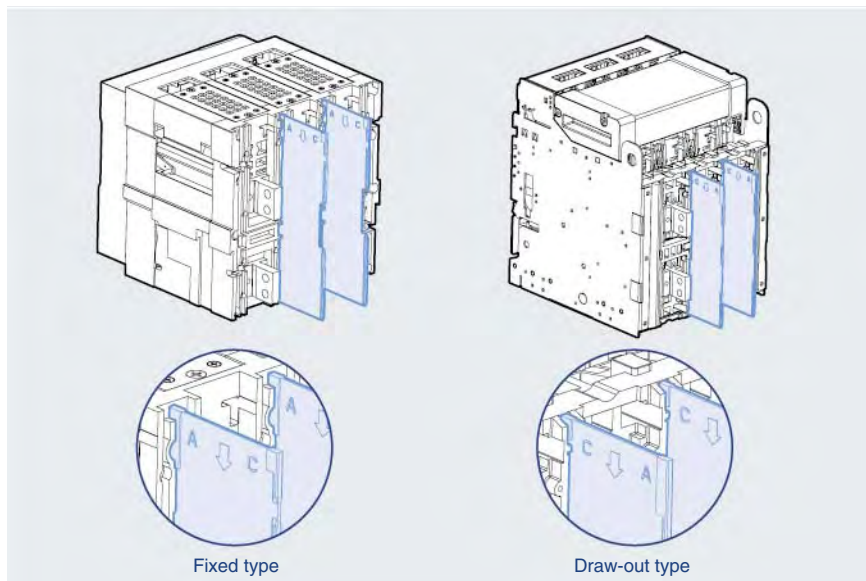

- Insulation barrier prevents the arc which may arise and result in short-circuit between phases in advance
- As "C" stands for "CRADLE", install the insulation barrier in the direction of "C" in case of Draw-out type.
- As "A" stands for "ACB main frame", install the insulation barrier in the direction of "A" in case of Fixed type.

# Accessories

Susol

## Cell Switch [CEL]

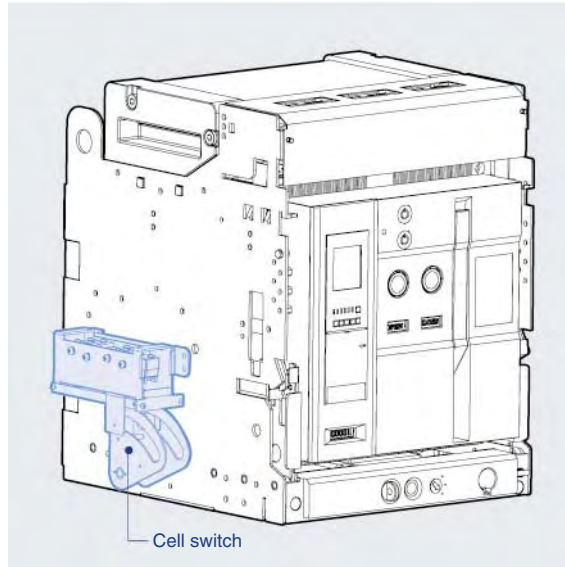
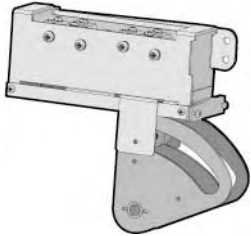

- It is a contact which indicates the present position of ACB. (CONNECTED, TEST, DISCONNECTED)

<Contact configuration>  
 4C: 1Disconnected +1Test +2Connected  
 8C: 2Disconnected +2Test +4Connected

※ Contact configuration can be changeable if necessary.

ACB position		DISCONNECTED		CONNECTED
Draw-in and draw-out position		DISCONNECTED	TEST	CONNECTED
Contact operation	CL-C (Connected)	OFF	OFF	ON
	CL-T (Test)	OFF	ON	OFF
	CL-D (Disconnected)	ON	OFF	OFF
Contact capacity	Voltage(V)		Resistive load	Inductive load
	AC	460V	5	2.5
		250V	10	10
		125V		
	DC	250V	3	1.5
		125V	10	10
30V		10	10	
Contact number		4C		

## Door Interlock [DI]

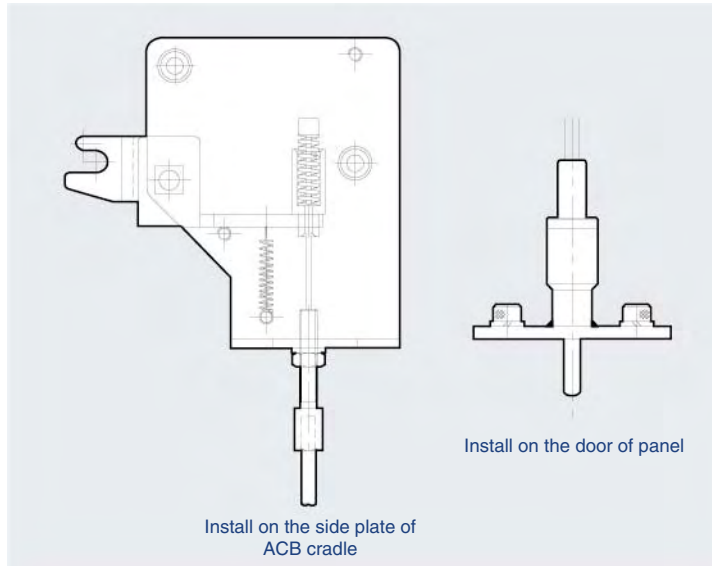

- It is a safety device which does not allow the panel door to open when a circuit breaker is in the "ON" position.

## Zero Arc Space [ZAS]

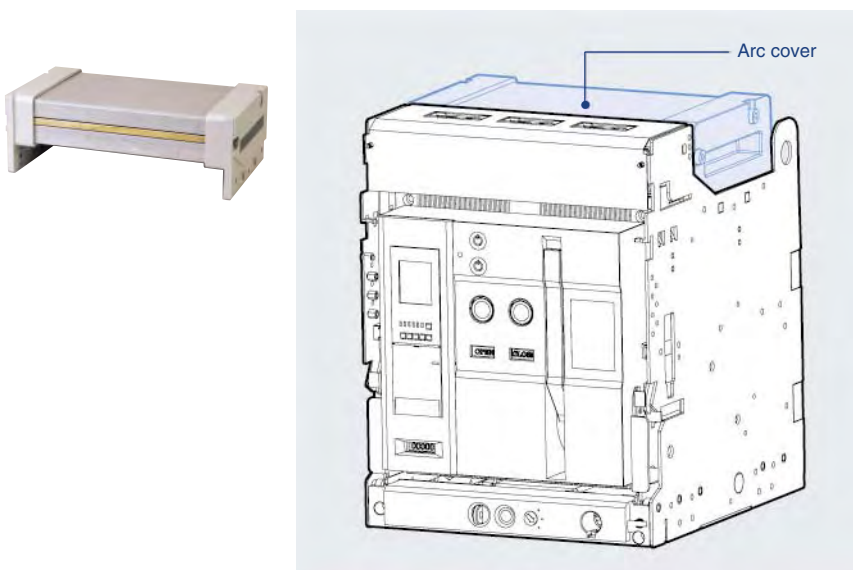

- Arc which may arise while breaking faulty current is extinguished first by Arc chute in main body of circuit breaker and then completely extinguished by Arc cover. By preventing arc from exposing to the outside, it protects itself from all kinds of accidents.

- It is categorized into 8 types by ratings and poles.

Ampere frame	Cover length (mm)
2000AF 3P	281.4
2000AF 4P	366.4
4000AF 3P	359.4
4000AF 4P	474.4
5000AF 3P	576.4
5000AF 4P	746.4
6300AF 3P	732.4
6300AF 4P	962.4

# Accessories

Susol

## Safety Control Cover [SC]

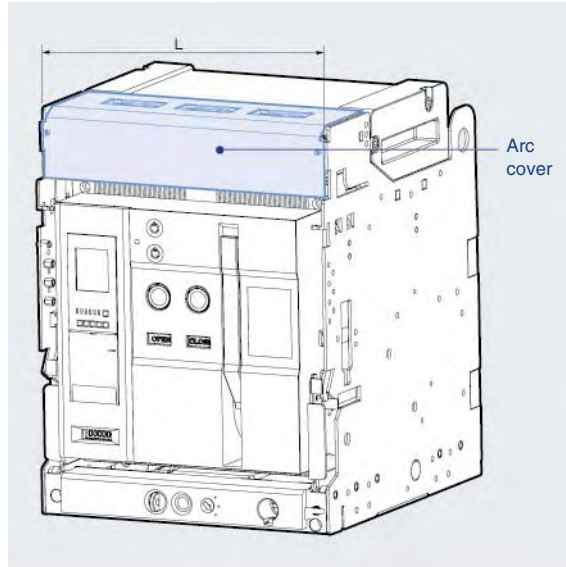
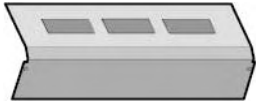

- It protects control terminals which exposes to the outside, and prevents the damages resulted from foreign substances.

- It is categorized into 8 types by ratings and poles.

Ampere frame	Cover length (mm)
2000AF 3P	334
2000AF 4P	419
4000AF 3P	412
4000AF 4P	527
5000AF 3P	629
5000AF 4P	799
6300AF 3P	785
6300AF 4P	1015

## Cradle Mounting Block [CMB]

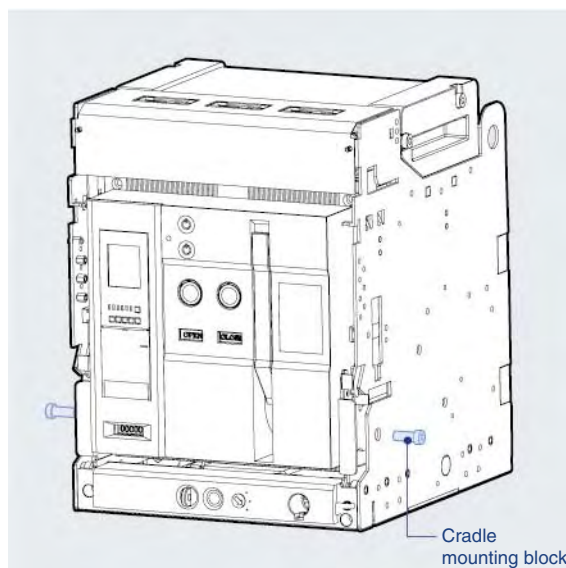

- It interlocks the main body of circuit breaker and cradle mechanically to fix the former in connected position. Therefore, all draw-in/outs are not available.



## Racking Interlock [RI]

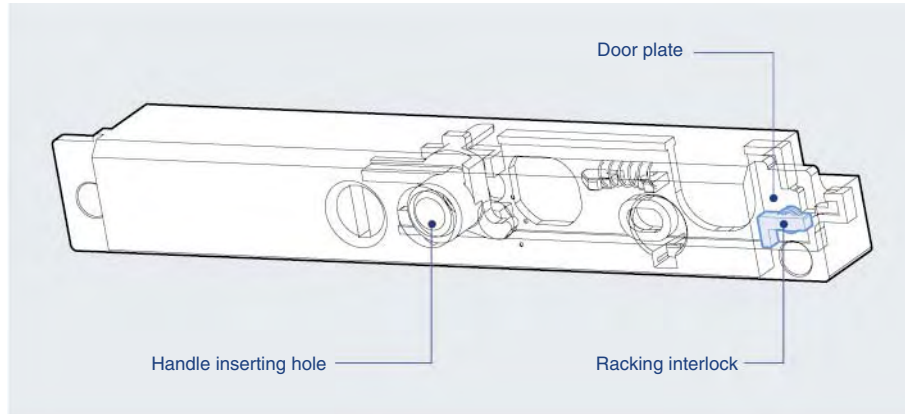

- When panel door is opened, Draw in/out handle doesn't be inserted. Thus, panel handle can be inserted only when panel door is closed.

## Pad Lock / Position Lock [PL]

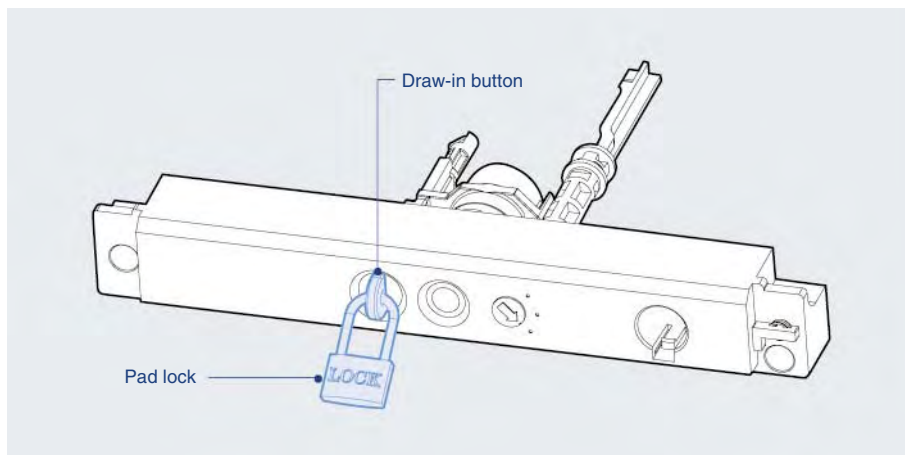

ACB is subject to restriction regarding moving in connected, test, disconnected when drawing in or out. If main body of ACB is placed in 3 positions, it is locked and stopped when drawing in or out.

- As shown in the figure, if draw-in/out button pops out, it means locking is operating.
- To continue Draw-in/out operation, release lock by pushing Draw-in/out button
- In case it is locked as shown in the figure above, main body of ACB can not be drawn in or out into the cradle.
- For the lock device, user has to purchase it.

# Accessories

Susol

## Miss Insertion Prevent Device [MIP]

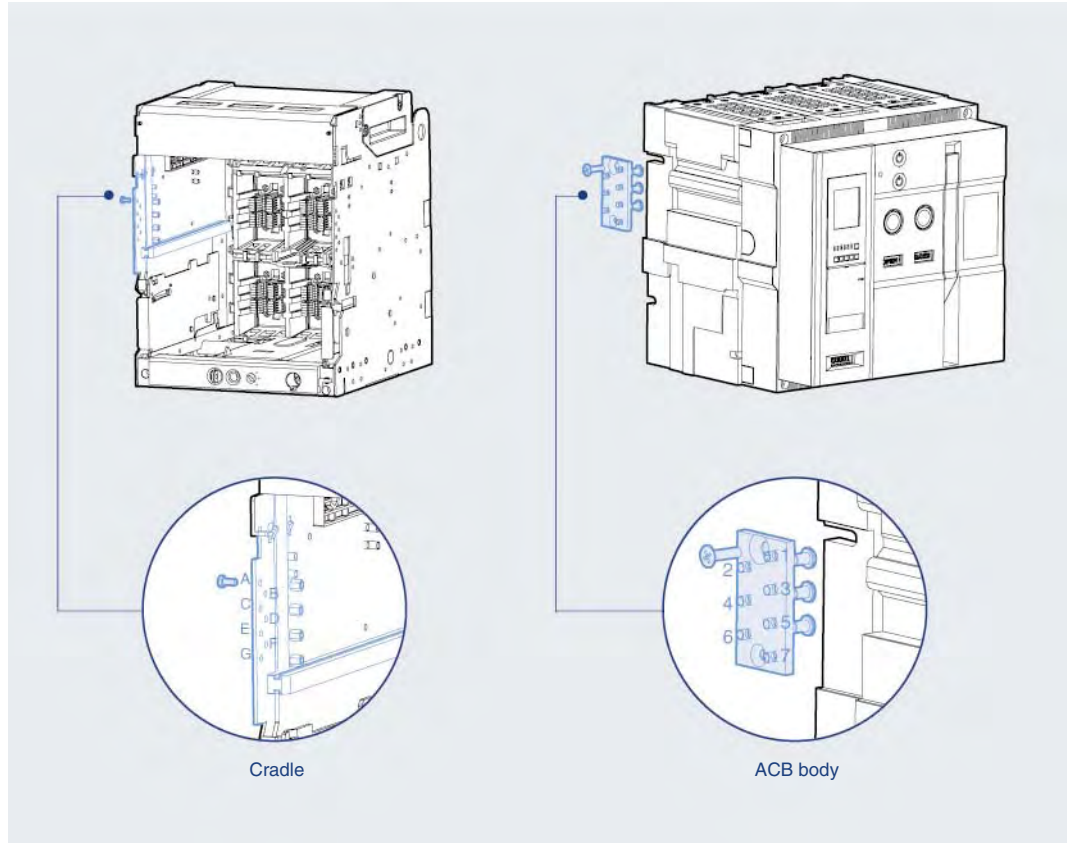

- When the main body of ACB is inserted to the cradle, if the ratings of ACB does not match with cradle, it mechanically prevents ACB from being inserted into cradle of ACB.
- The installation method is variable according to ratings.

Cradle	ACB	Cradle	ACB	Cradle	ACB	Cradle	ACB
ABCD	567	ADEF	237	ABEG	346	BCEG	146
ABCE	467	ADEG	236	ABFG	345	BDEF	137
ABCF	457	ADFG	235	ACDE	267	BDEG	136
ABCG	456	AEFG	234	ACDF	257	BDFG	135
ABDE	367	BCDE	167	ACDG	256	CDEF	127
ABDF	357	BCDF	157	ACEF	247	CDEG	126
ABDG	356	BCDG	156	ACEG	246	CEFG	124
ABEF	347	BCEF	147	ACFG	245	DEFG	123

## UVT Time Delay Controller [UDC]

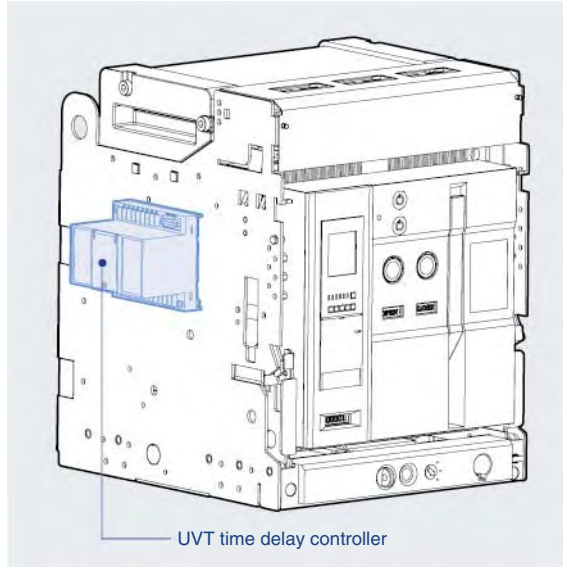
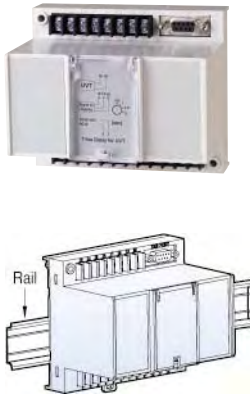

- UVT is a device which makes ACB tripped automatically to prevent the accident on load side due to under voltage or power breakdown. There are two types, Instantaneous type and time delay type.
- It can be installed on the rail or to the cradle.
- Instantaneous type: only available with UVT coil.
- Time delay type: available by connecting UVT coil and UVT time delay controller.
- Common use for the all types.

### 1. The rated voltage and characteristic of UVT time delay controller

Rated voltage [Vn]		Operating voltage range [V]		Power consumption (VA or W)		Trip time[s]
DC [V]	AC [V]	Pick up	Drop out	Inrush	Steady-state	
48~60	48	0.65~0.85 Vn	0.4~0.6 5Vn	200	5	0.5, 1, 1.5, 3
100~130	100~130					
200~250	200~250					
-	380~480					

Note) Operating voltage range is the min. rated standard for each rated voltage (Vh).

### 2. Wiring

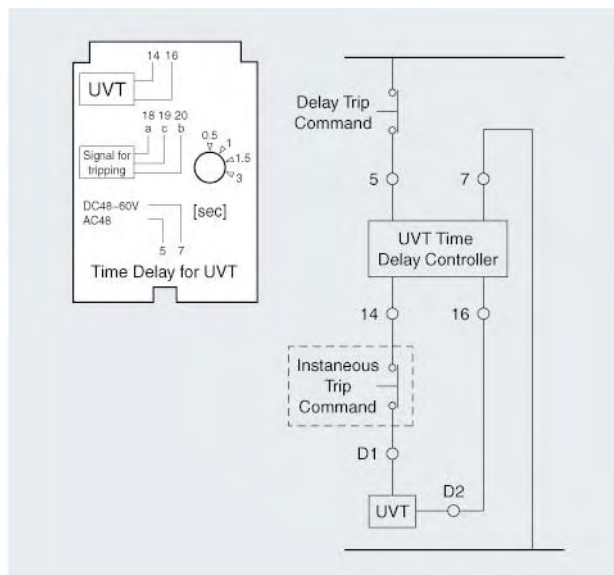

# Accessories

Susol

## Temperature Alarm [TM]

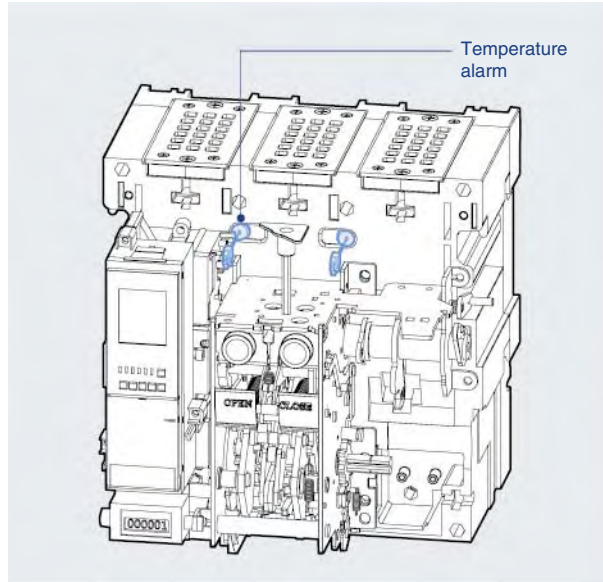

- Temperature Alarm Unit is a device to show the temperature through a sensor inside of ACB.
- The temperature sensor can be installed up to 4 and the output is connected to control terminal blocks.
- It displays the maximum temperature of them and transmits through a network.
- If the temperature is higher than a standard, an alarm can occur.
- Temperature alarm unit communicates with Modbus / RS-485 basically, Profibus-DP need to be purchased separately.
- Temperature alarm unit is installed on the cradle or the inside of panel.



Temperature alarm

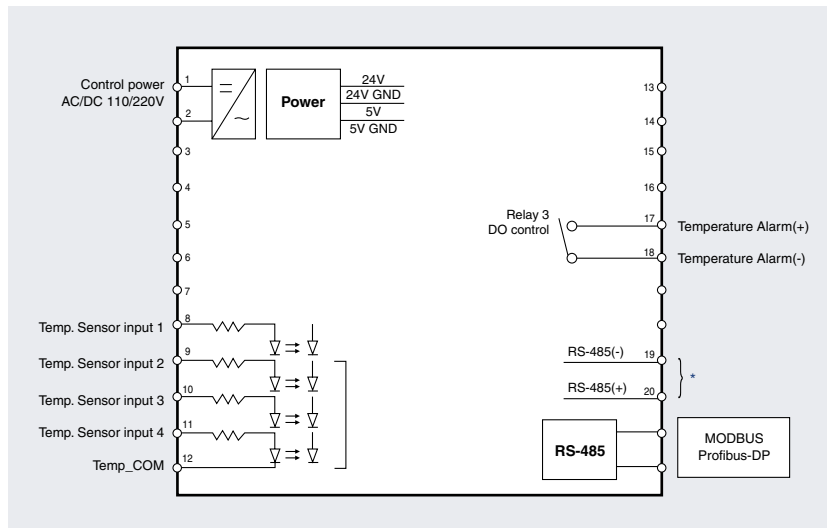
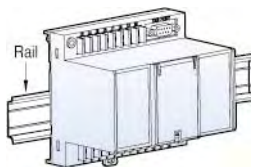

\*In case of using Profibus-DP communication, it needs to communicate with ACB trip relay.

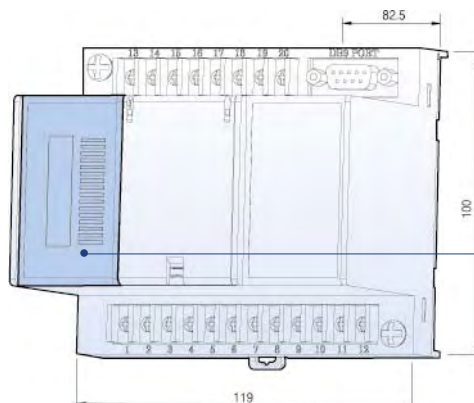

Temperature LED(°C): 10 ~150°C,  
Warning  
(Indicates the maximum value)

## Remote I/O Unit [RCO]



Remote I/O Unit

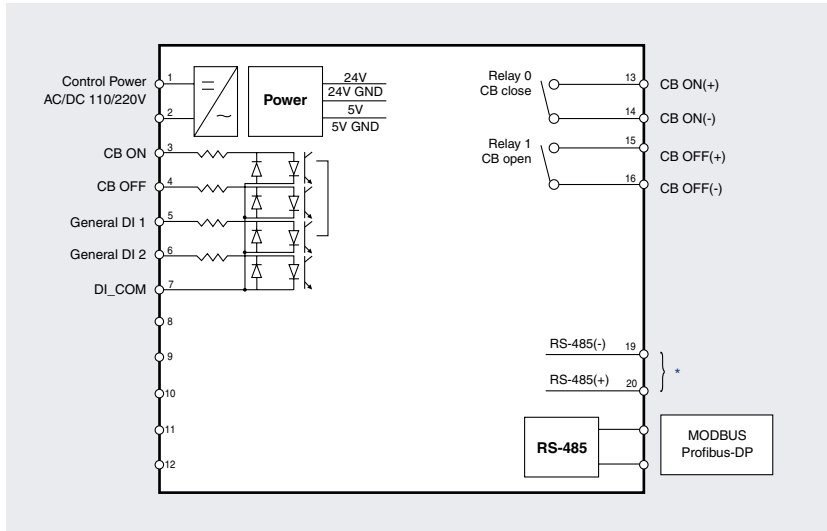
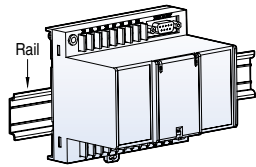

\*In case of using Profibus-DP communication, it needs to communicate with ACB trip relay.

Classification		Applied range	Remarks
CB control	Contact switching capacity	AC230V 16A / DC30V 16A	
	Max. switching capacity	3680VA, 480W	
Alarm	Contact switching capacity	AC230V 6A / DC25V 6A	Induction load (cosØ=0.4, L/R=7ms)
	Max. switching capacity	1880VA, 150W	

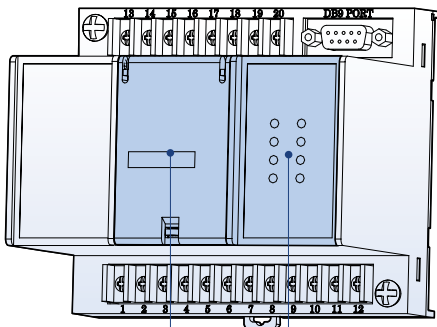

- Baud rate setting
- Comm. address setting
- Temperature setting

- Remote I/O unit has the I/O contact which can trip or close the ACB from the remote site by communication.
- For the General DO, the output of DI1 or DI2 is selectable.
- Remote I/O Unit communicates with Modbus / RS-485 communication basically, Profibus-DP need to be purchased separately.
- It supports SBO (Select Before Operation) function and guarantees the control reliability.
- Remote I/O Unit can be installed on the cradle of ACB or the inside of panel.

LED	Status	
1	DI1	Indicates digital Input #1condition
2	DI2	Indicates digital Input #2condition
3	DO ON	Indicates temperature alarm output is ON
4	DO OFF	Indicates temperature alarm output is OFF
5	CB ON	Indicates circuit break close condition
6	CB OFF	Indicates circuit break open condition
7	RUN LED	Indicates unit run condition
8	CB ERROR	Indicates circuit break terminal Disconnection / control Err condition

# Electrical diagram

Susol

This diagram is based on "CONNECTED" position of a circuit breaker and Opening, Motor charging, Releasing of locking plate should be normal condition.

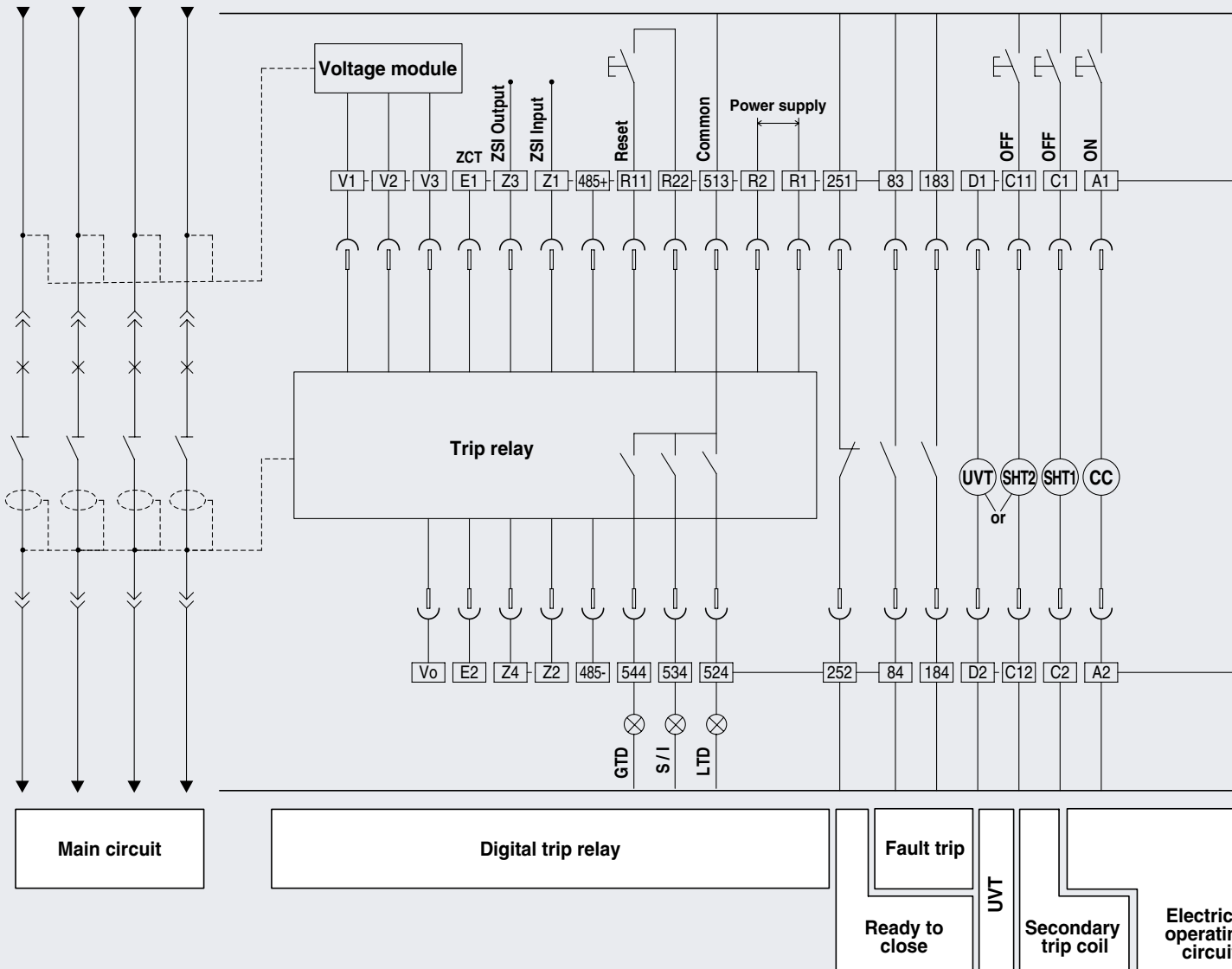

13	14	~	63	64	Auxiliary switch "a"
11	12	~	61	62	Auxiliary switch "b"
413	414				Charged signal
423	424				Charged signal communication
U1	U2				Motor charging
A1	A2				Closing coil
C1	C2				Shunt trip
C11	C12				2nd shunt trip

D1	D2	Voltage input terminal of UVT	
83	84	Alarm1 "a"	
183	184	Alarm2 "a"	
251	252	Ready to close switch	
R1	R2	Control power	
513	~	544	Alarm contact
R11	R22	Alarm reset (Trip cause LED, Alarm contact)	
Z1	Z2	ZSI Input	

- Note) 1. The diagram is shown with circuits de-energized, all devices open, connected and charged and relays in normal position  
 2. The standard of auxiliary contact is "3a3b"  
 3. Option  
 - Ready to close contact, Trip alarm contact, UVT coil, Fully charged contact, secondary trip coil  
 - Cell switch, Temperature module, Voltage module, Remote close-open module, ZCT, ZSI

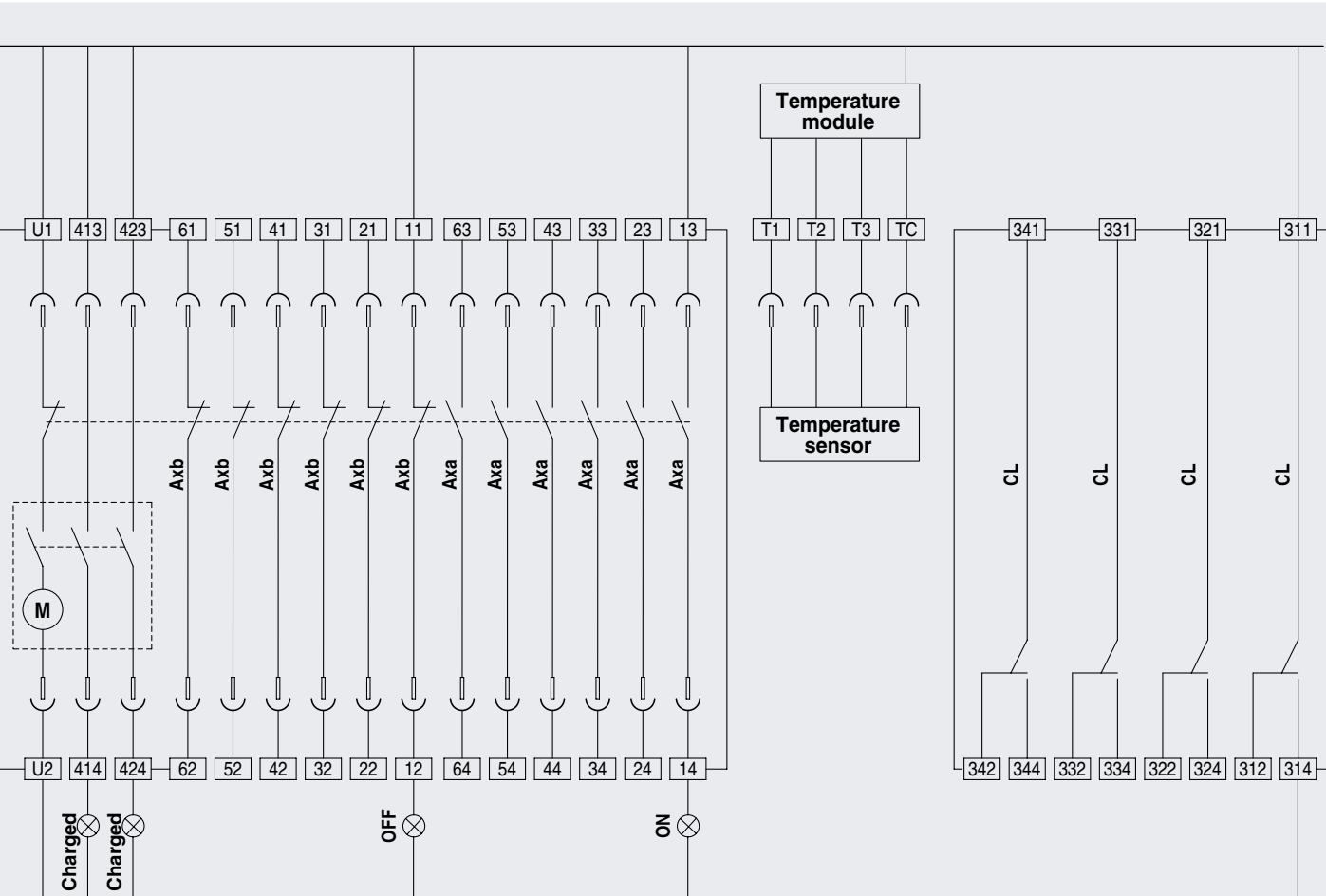

**Charge completion contact**

**Auxiliary Switch**

**Thermal, communication remote control module**

**Cell switch**

Z3	Z4	ZSI output
E1	E2	ZCT
VN	~ V3	Voltage module
TC	~ T3	Temperature module
311	~ 344	Position switch
Ax		Auxiliary switch
LTD		Long time delay trip indicator
S/I		Short time delay/instantaneous

GTD	Ground fault trip indicator
CL	Cell switch
(M)	Motor
(CC)	Closing coil
(SH1)	Shunt tripping device 1
(SH2)	Shunt tripping device 2
(UVT)	UVT coil

# Dimensions

Susol

## Fixed type 2000AF (630~1600A)

### Front view

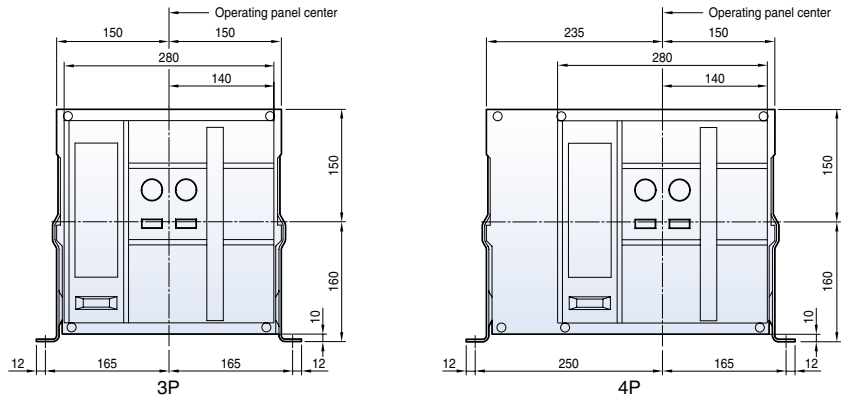

### Vertical type

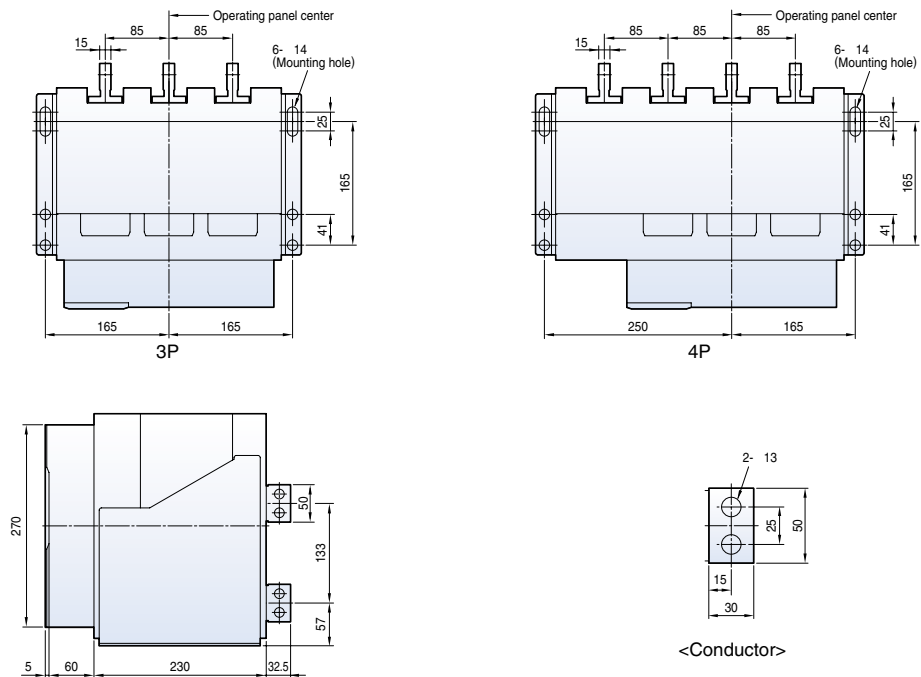

### Door frame: DF

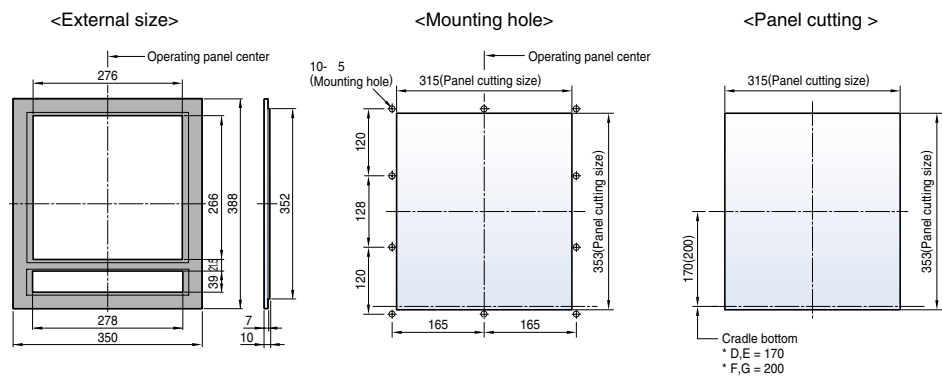



Horizontal type

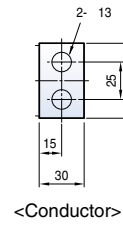
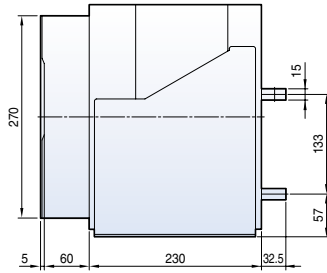
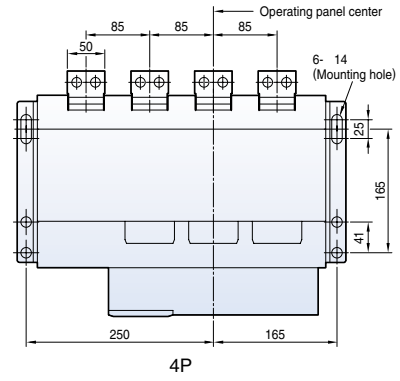
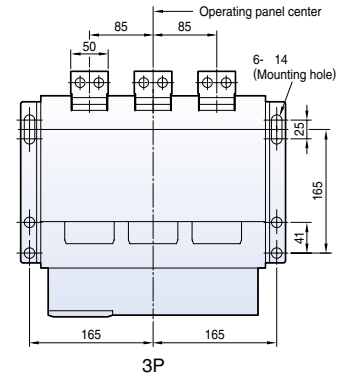

Front connection type

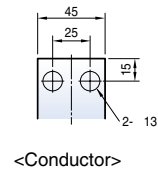
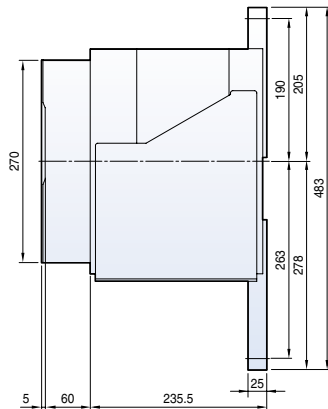
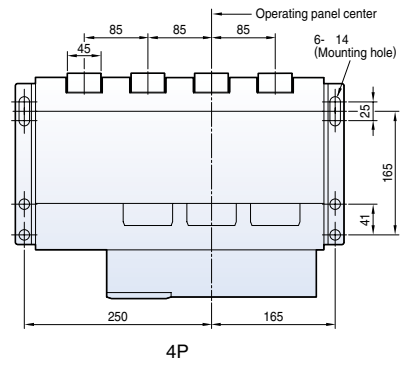
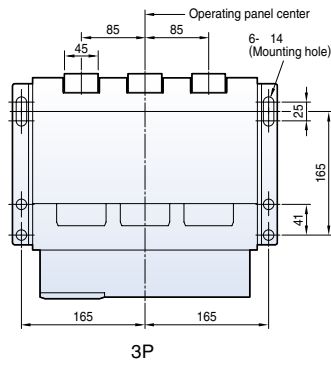

# Dimensions

Susol

## Draw-out type 2000AF (630~1600A)

### Front view

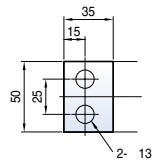
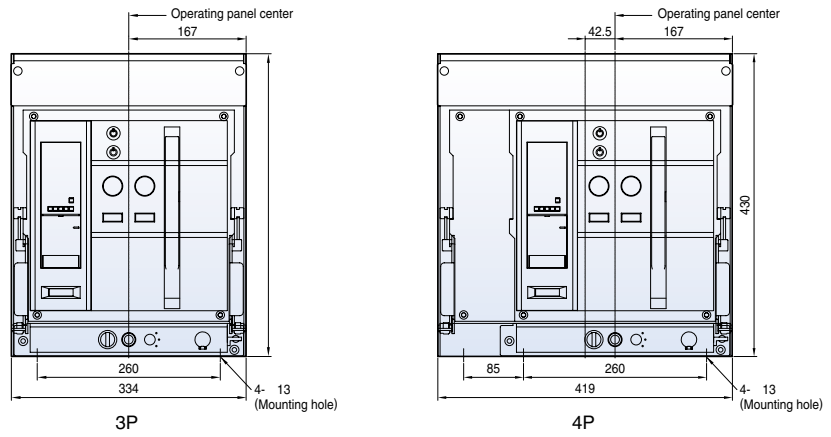

<Conductor>

### Vertical type

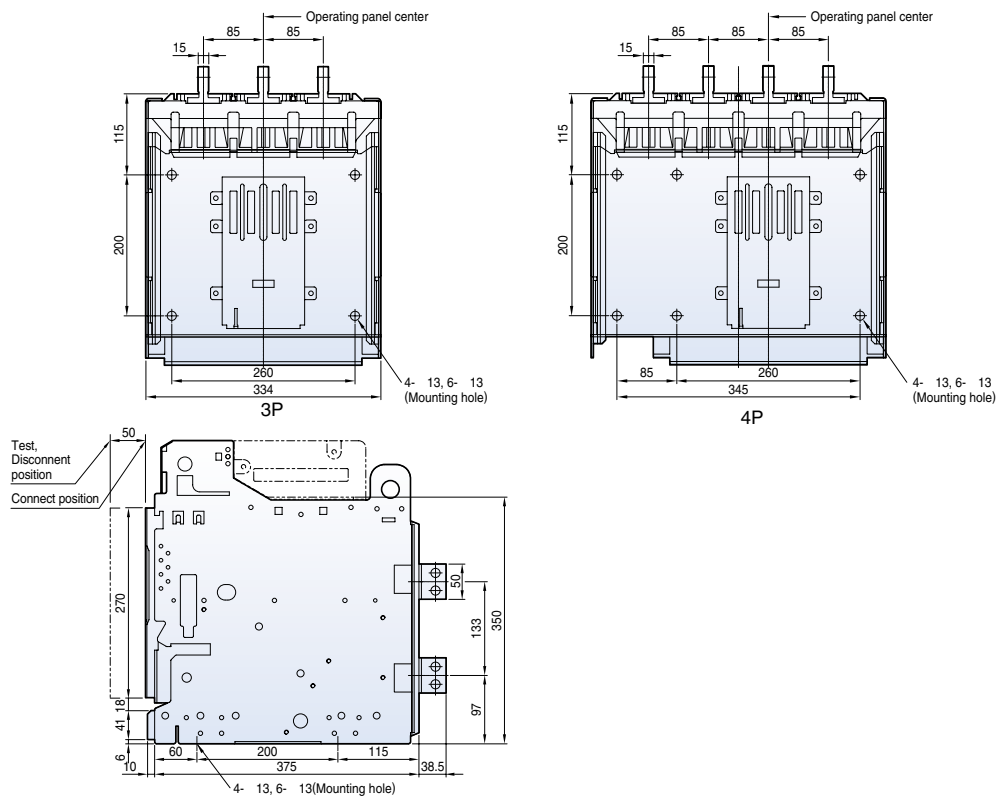

Horizontal type

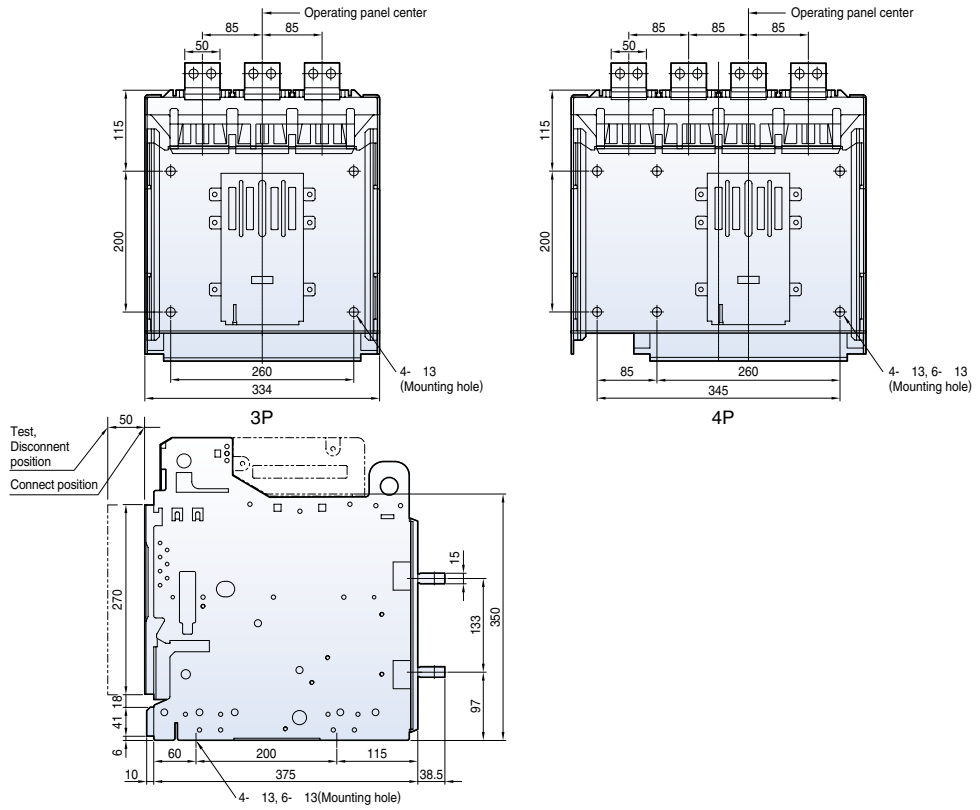

Front connection type

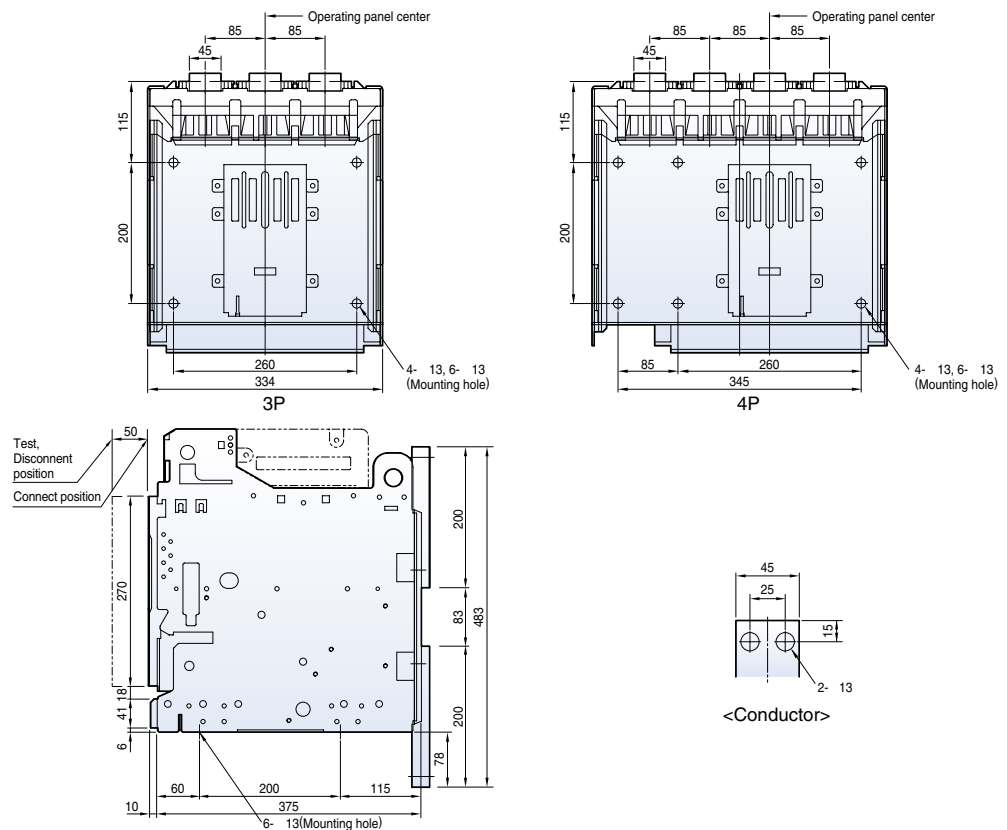

# Dimensions

Susol

## Fixed type 2000AF (2000A)

### Front view

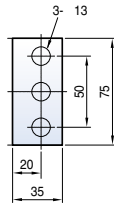
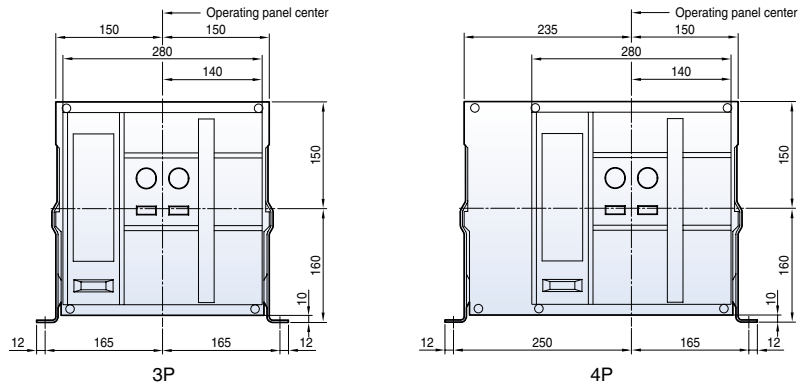

<Conductor>

### Vertical type

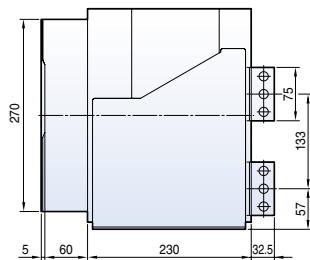
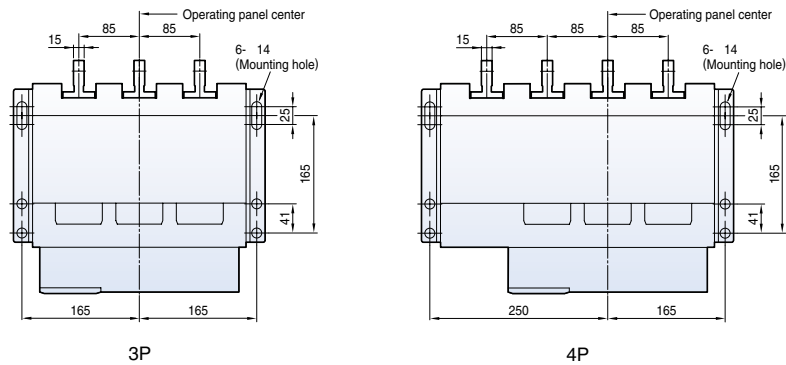

## Draw-out type 2000AF (2000A)

### Front view

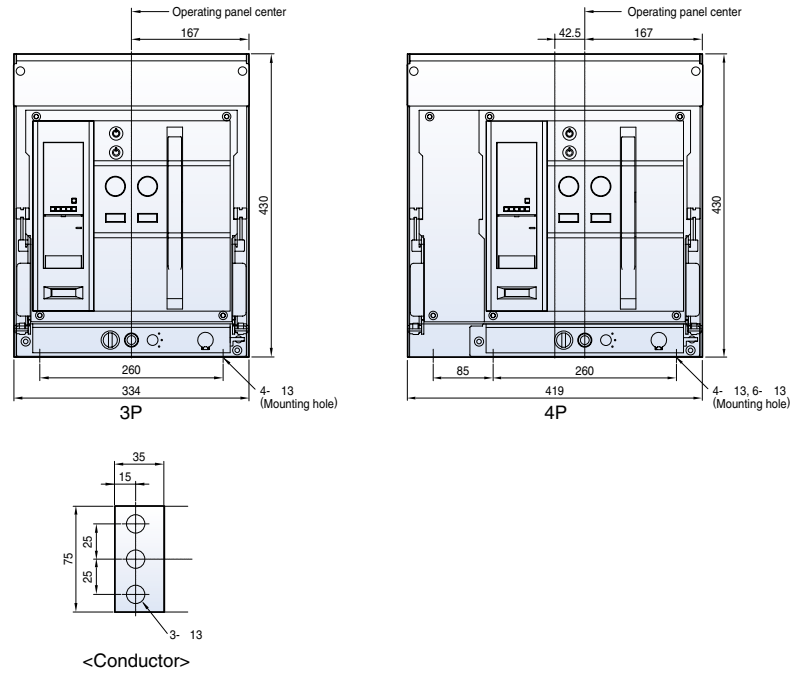

### Vertical type

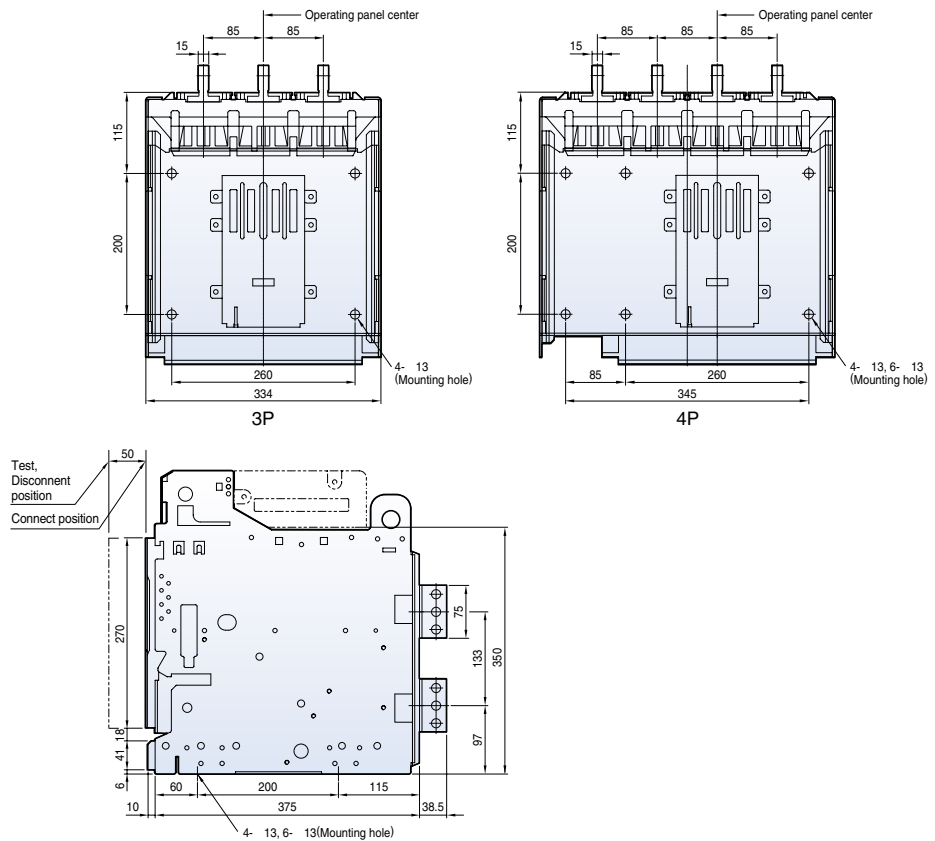

# Dimensions

Susol

## Fixed type 4000AF (630~3200A)

### Front view

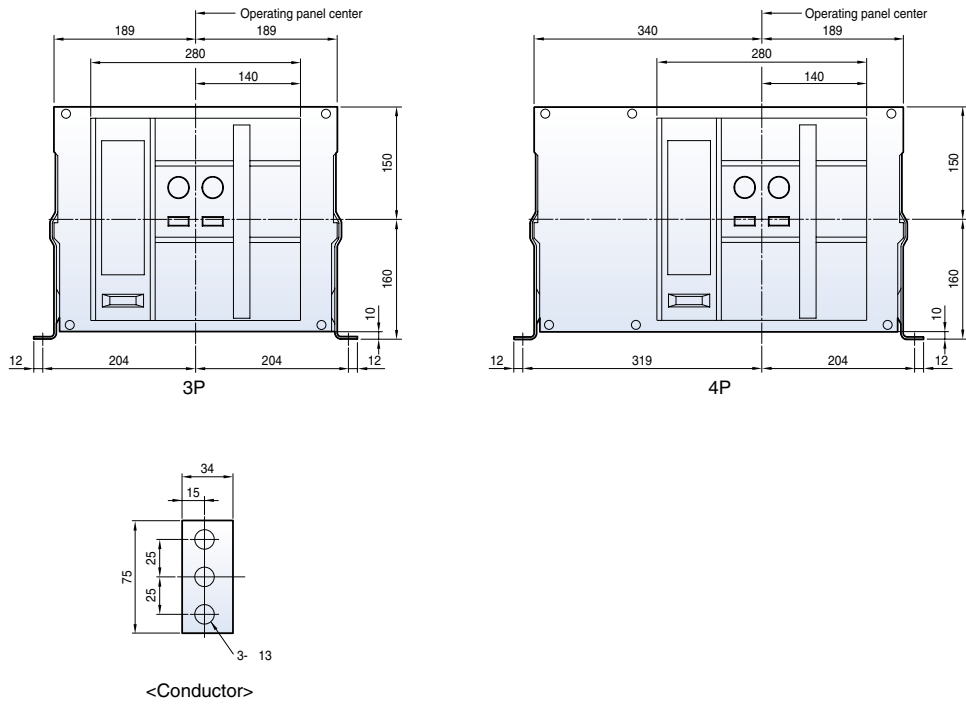

### Vertical type

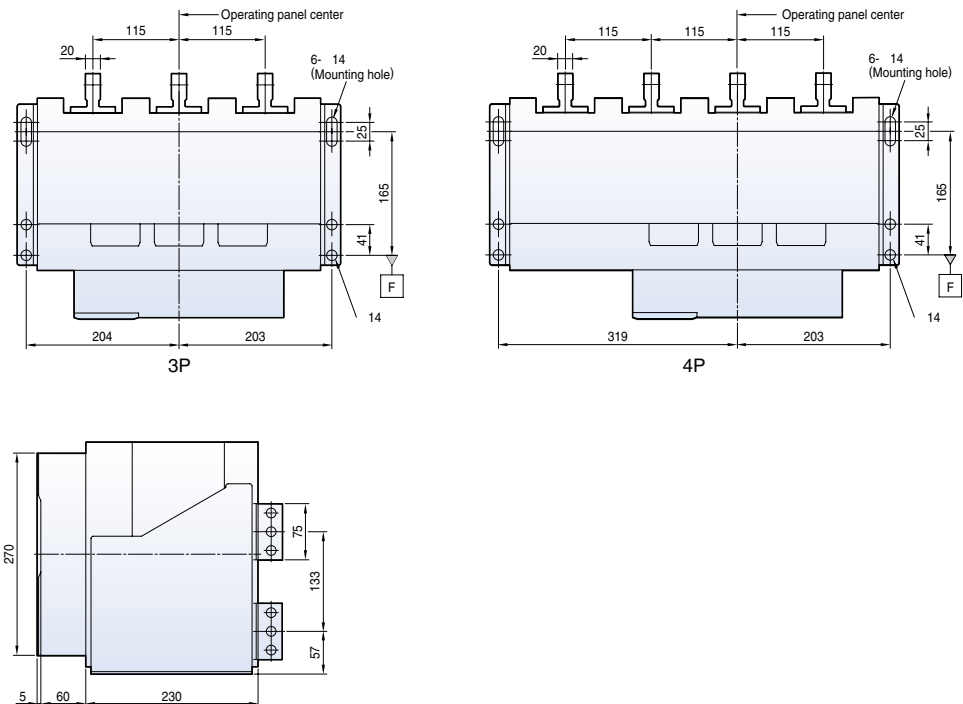

Horizontal type

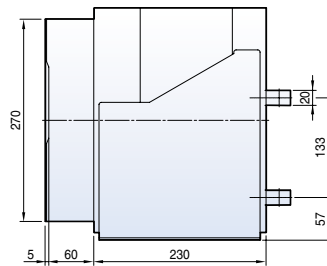
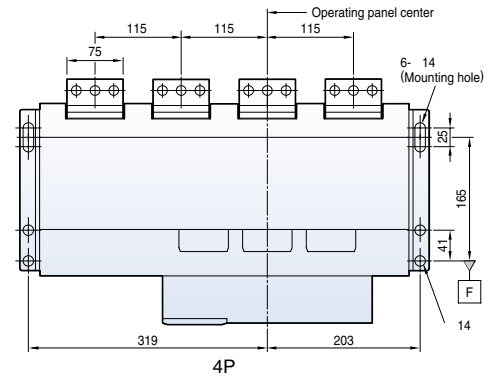
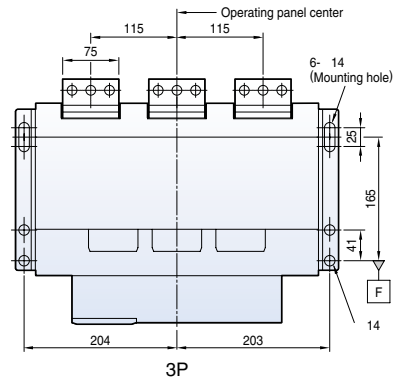

Front connection type

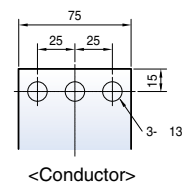
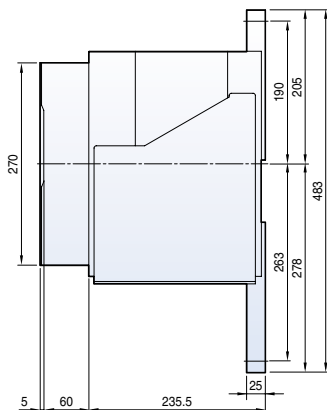
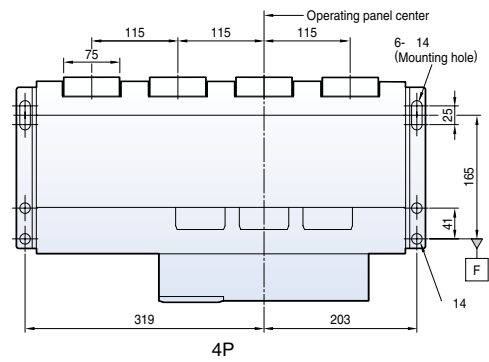
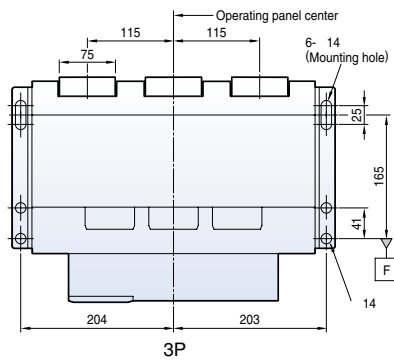

# Dimensions

Susol

## Draw-out type 4000AF (630~3200A)

### Front view

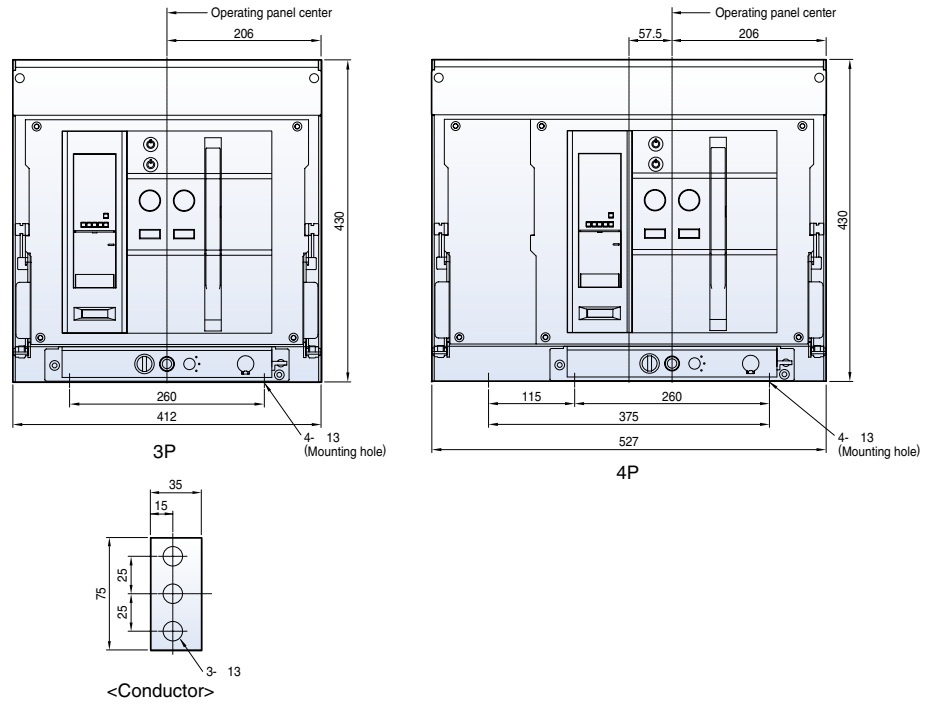

### Vertical type

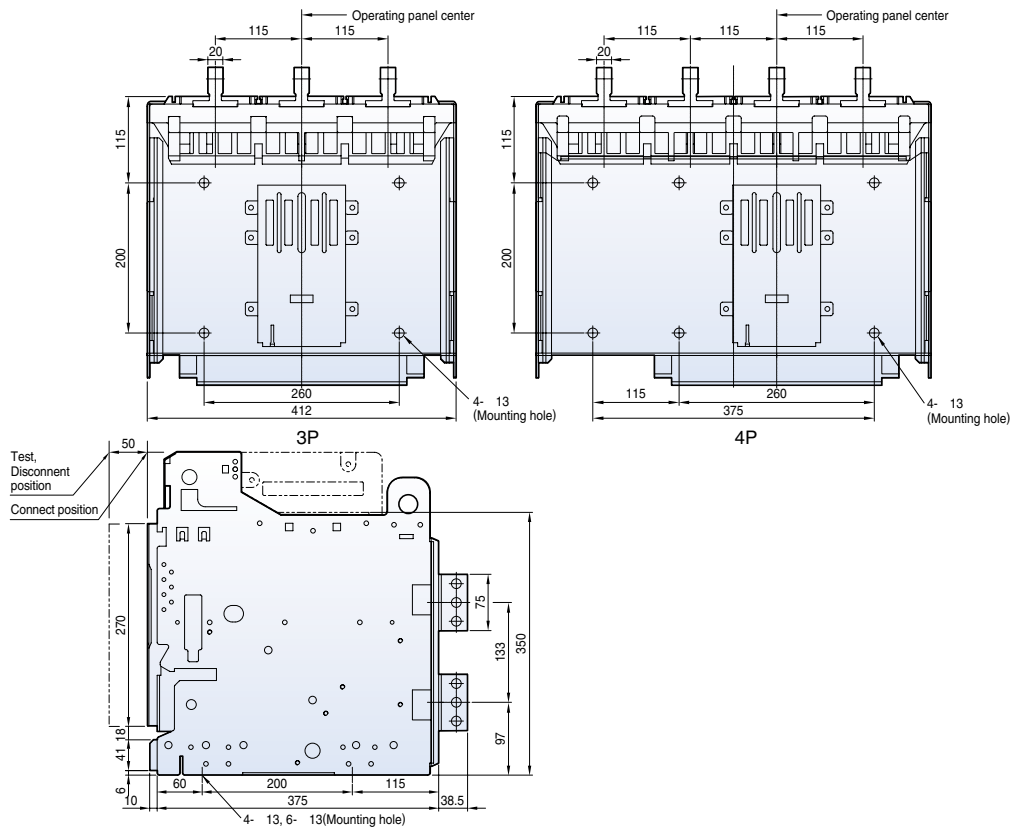



## Horizontal type

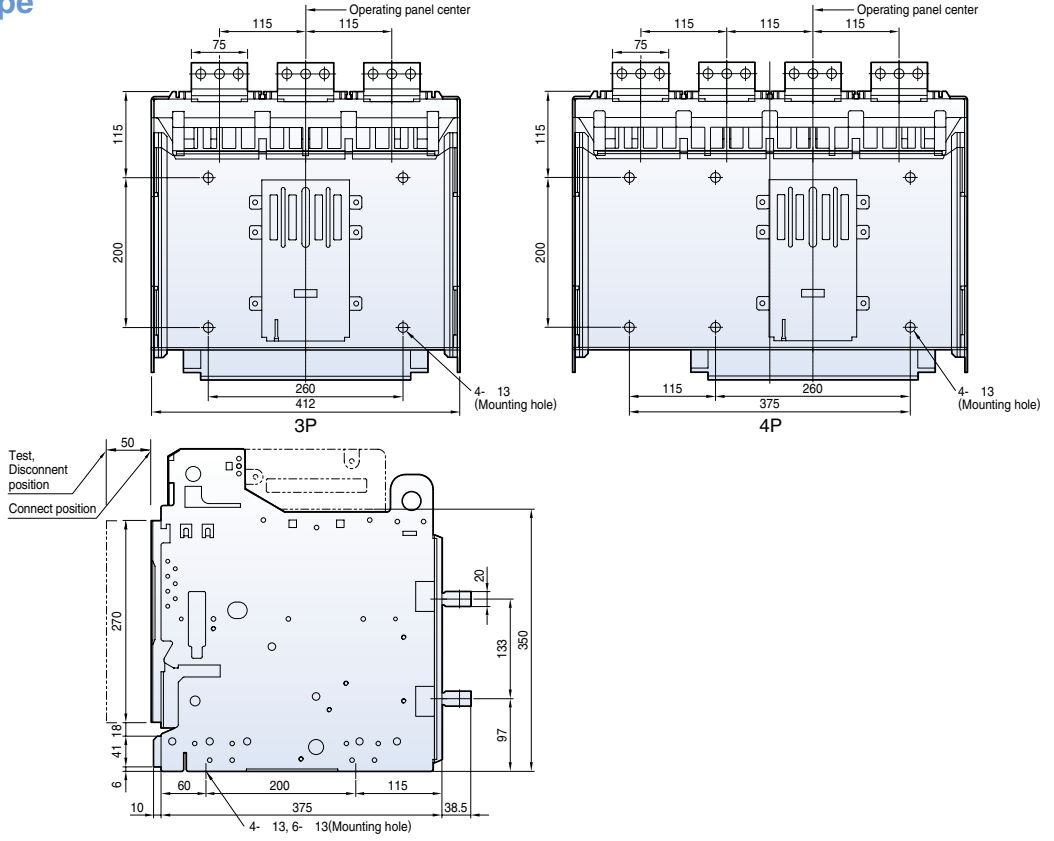

## Front connection type

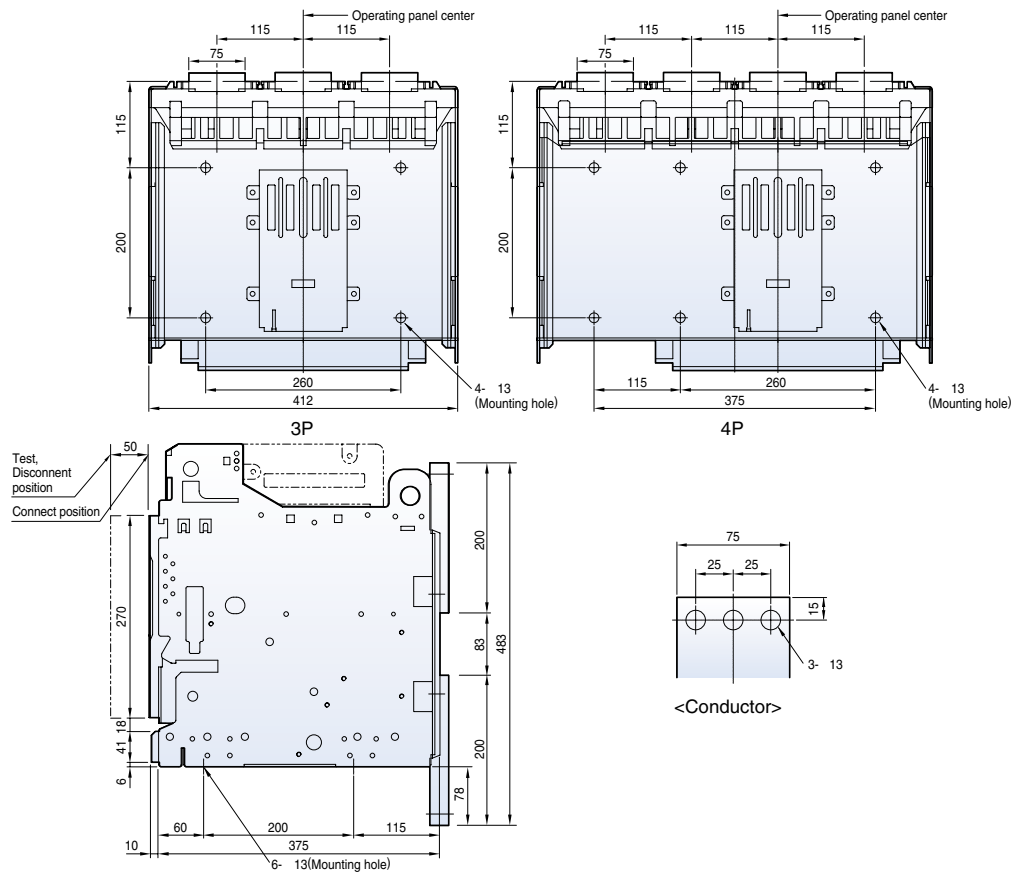

# Dimensions

Susol

## Fixed type 4000AF (4000A)

### Front view

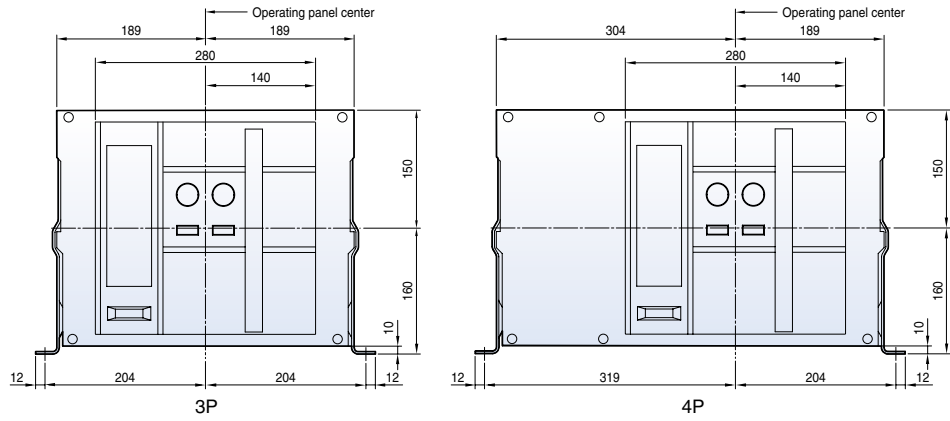

### Vertical type

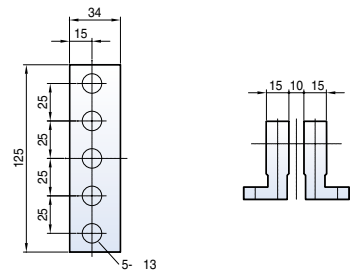
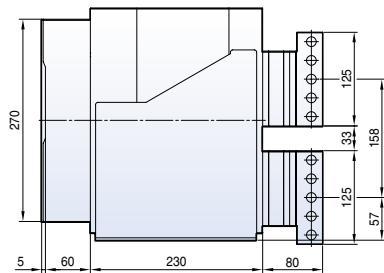
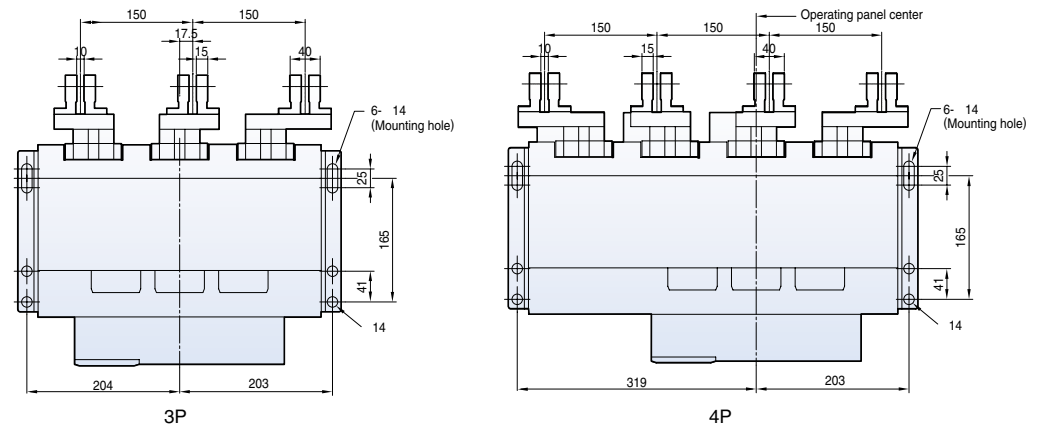

<Conductor>

Horizontal type

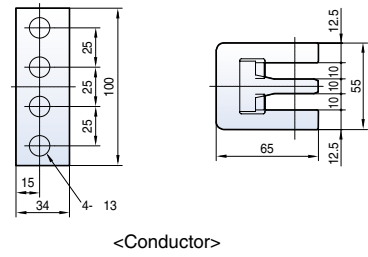
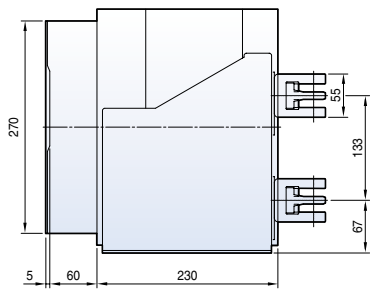
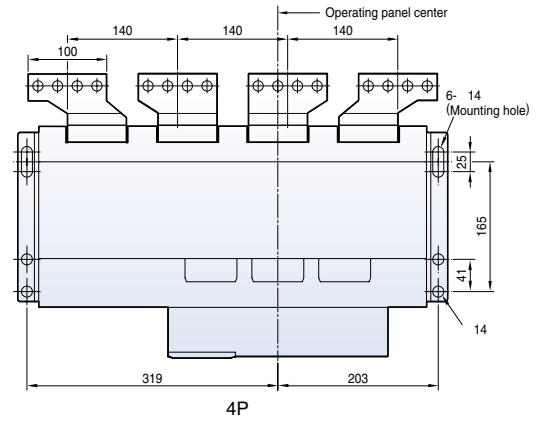
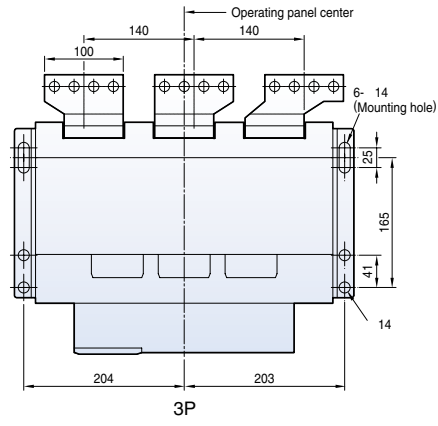

# Dimensions

Susol

## Draw-out type 4000AF (4000A)

### Front view

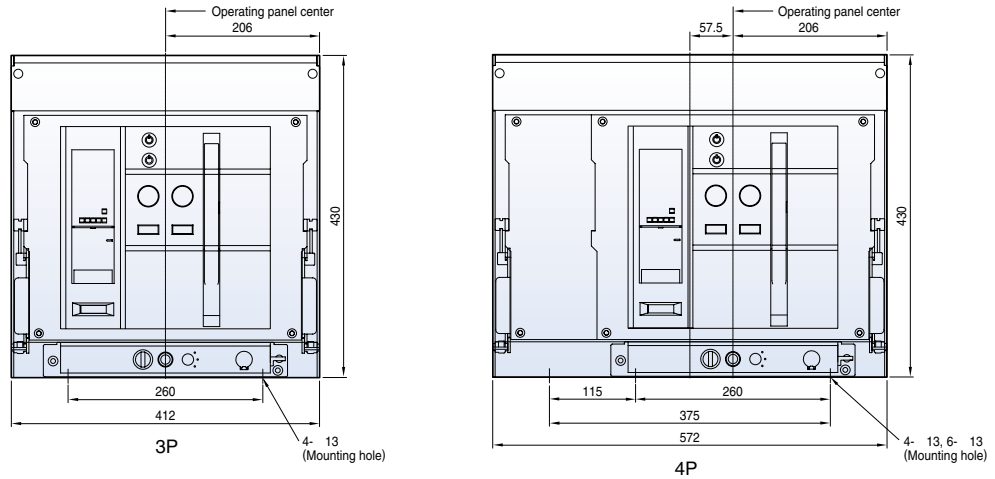

### Vertical type

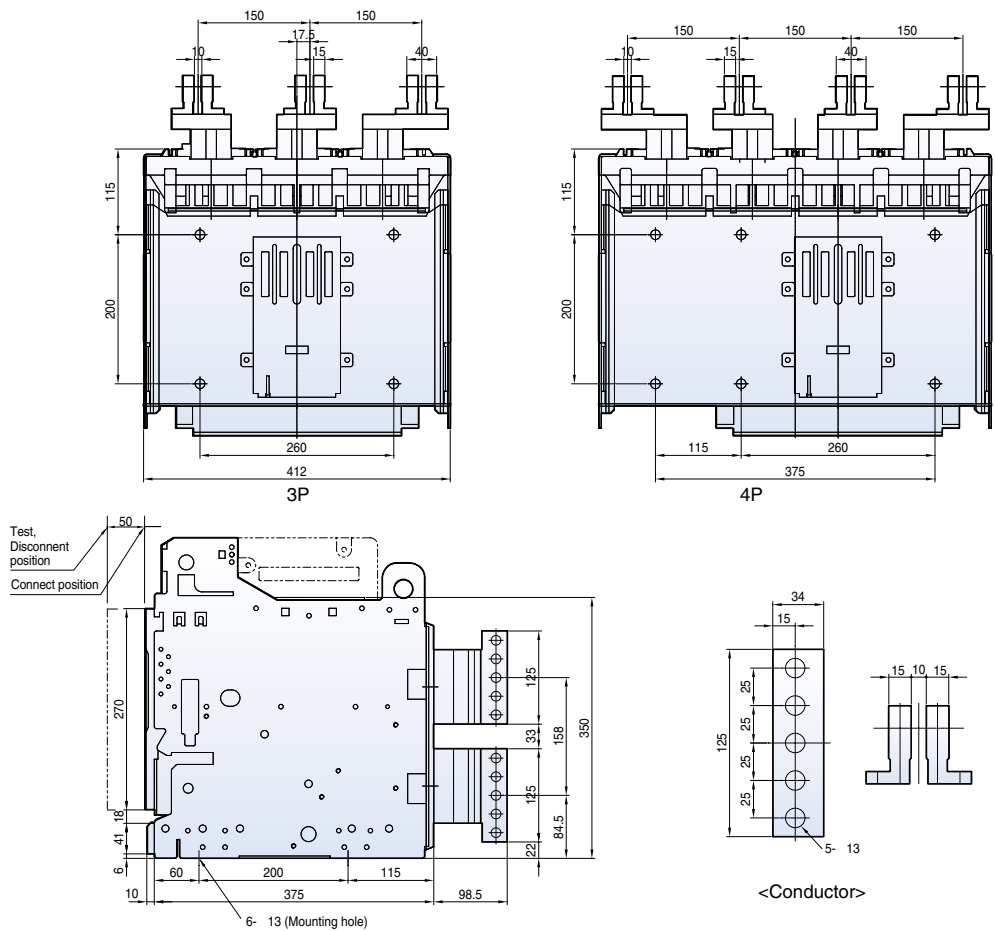

Horizontal type

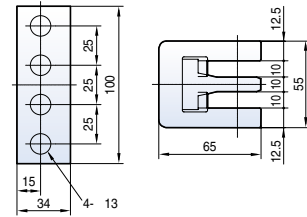
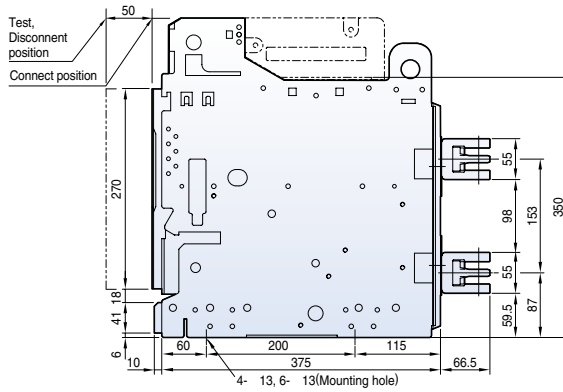
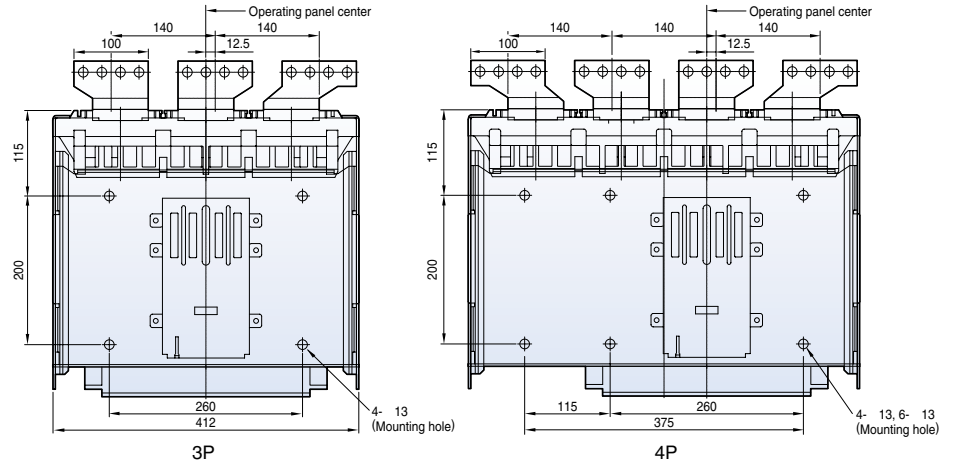

<Conductor>

# Dimensions

Metasol

## Fixed type 5000AF (4000~5000A)

### Front view

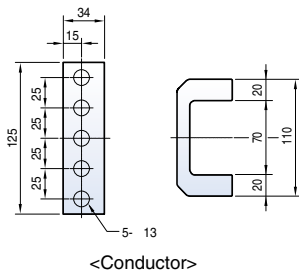
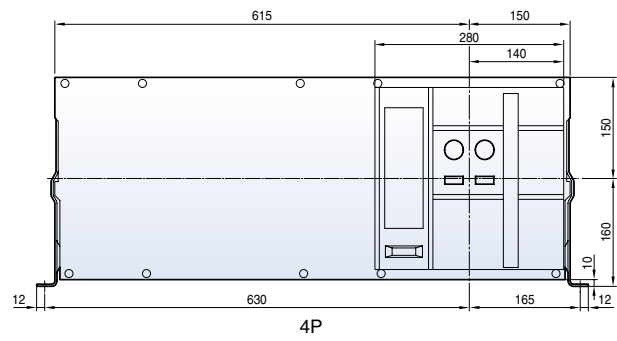
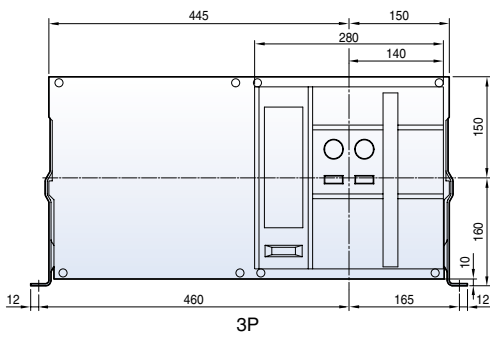

### Vertical type

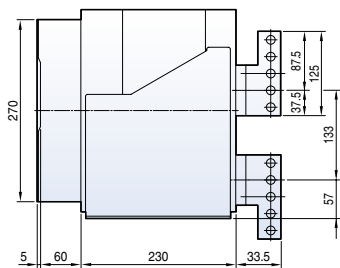
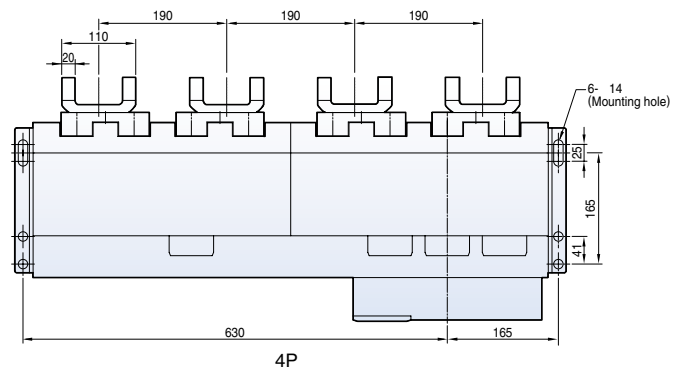
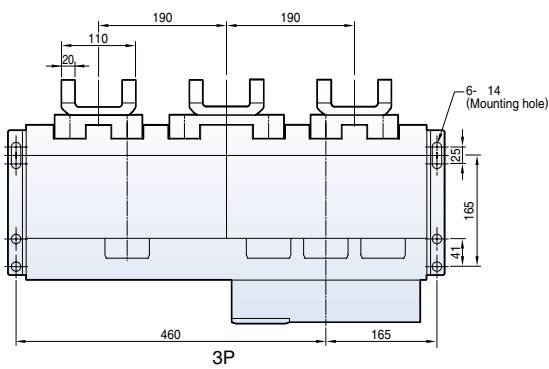

## Horizontal type

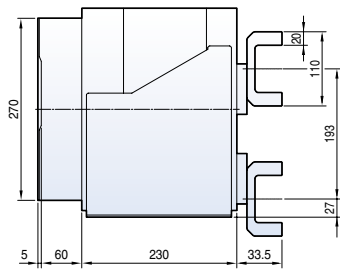
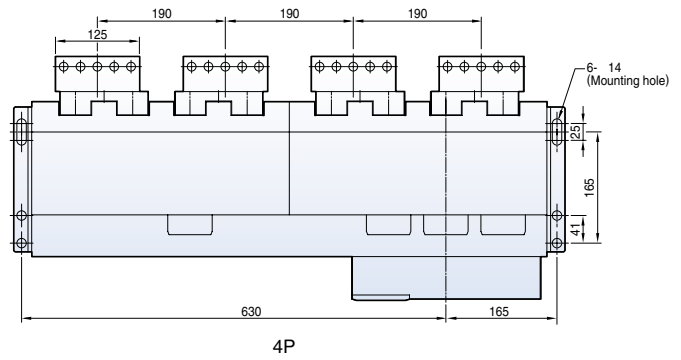
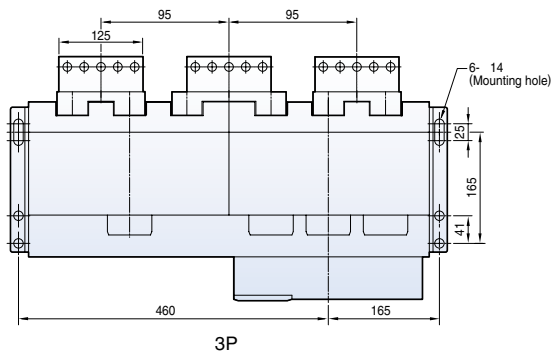

# Dimensions

Metasol

## Draw-out type 5000AF (4000~5000A)

### Front view

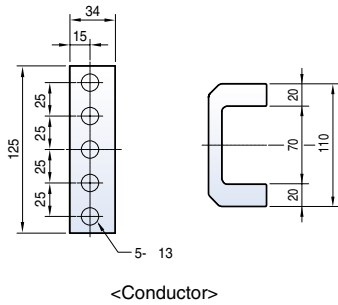
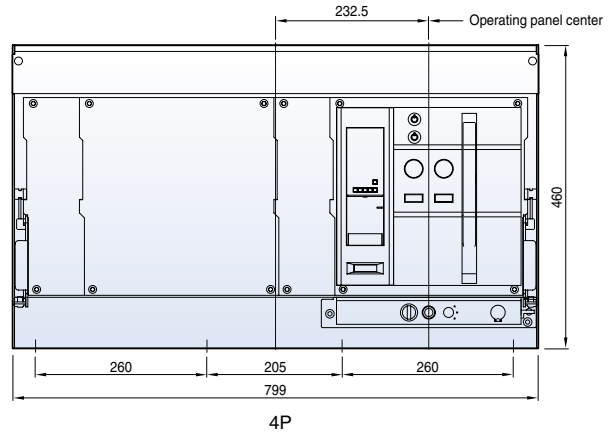
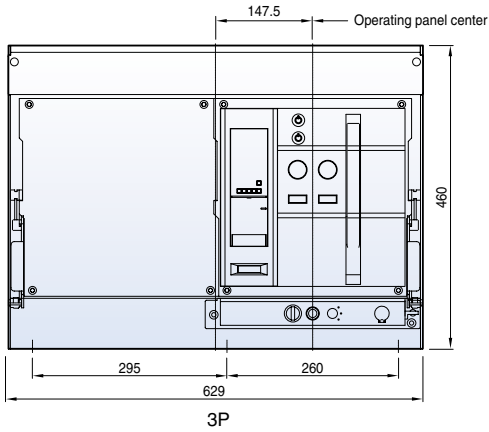

### Vertical type

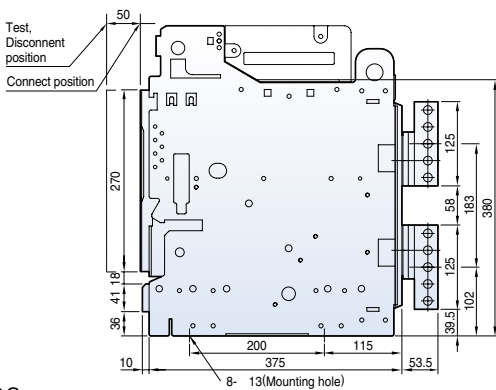
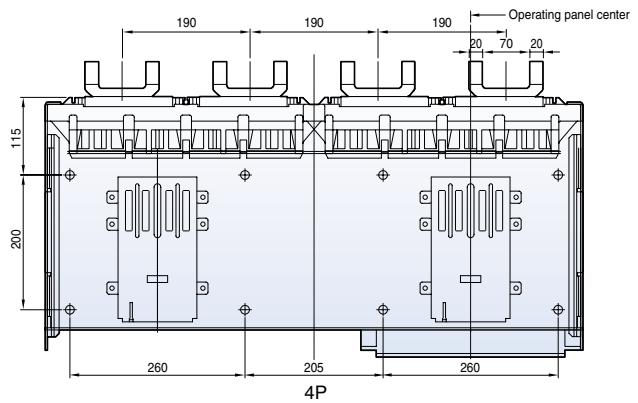
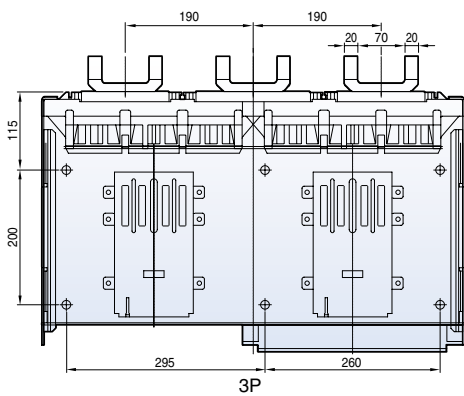



## Horizontal type

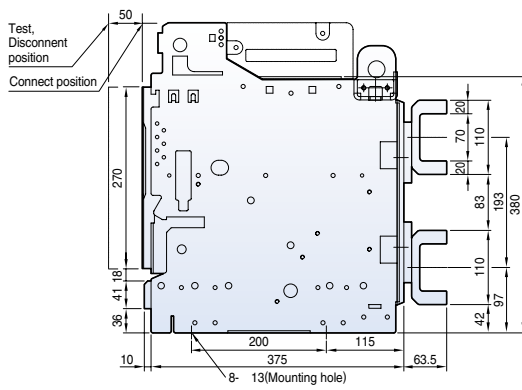
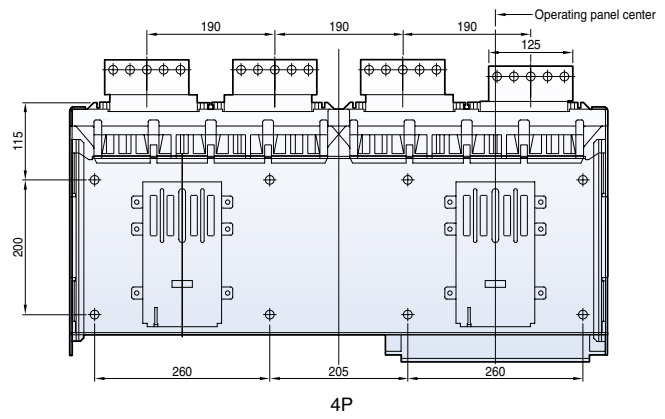
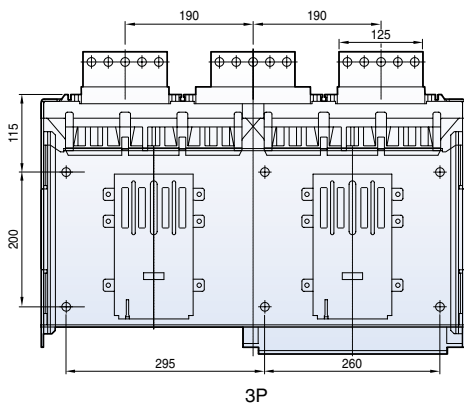

# Dimensions

Susol

## Fixed type 6300AF (4000A~6300A)

### Front view

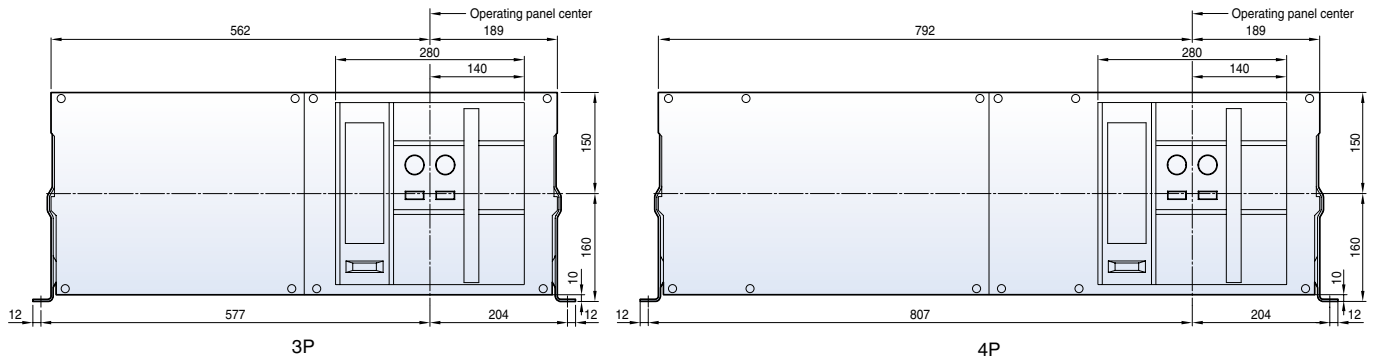

### 4000A~5000A

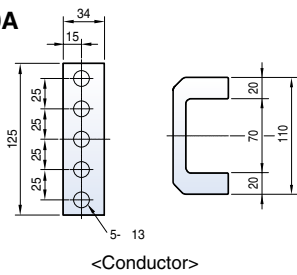

### 6300A

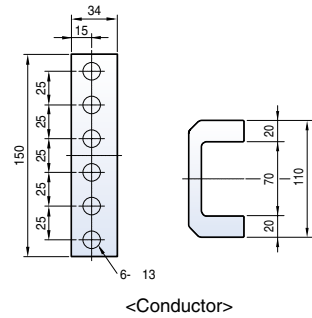

### Vertical type

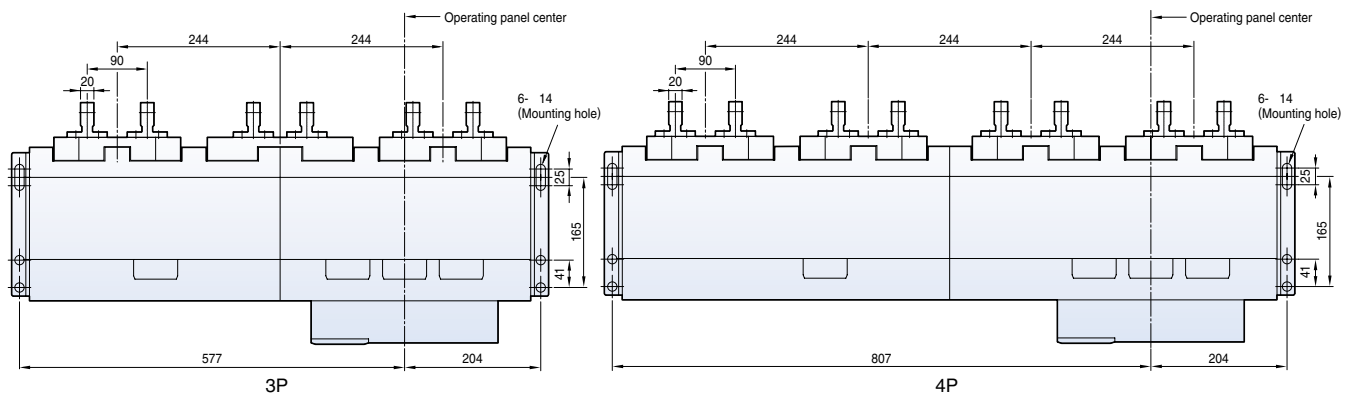

### 4000A~5000A

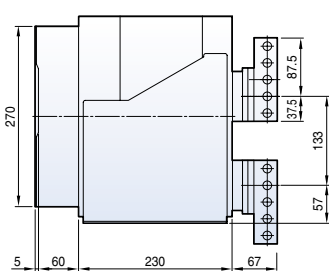

### 6300A

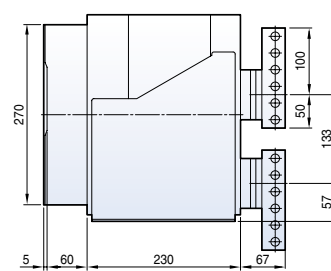

## Horizontal type

### 4000A~5000A

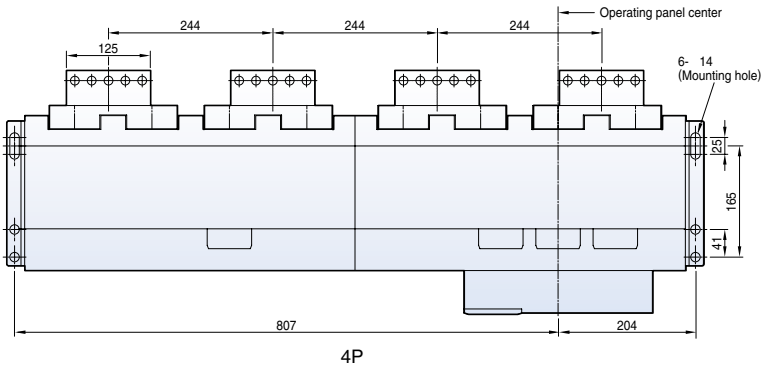
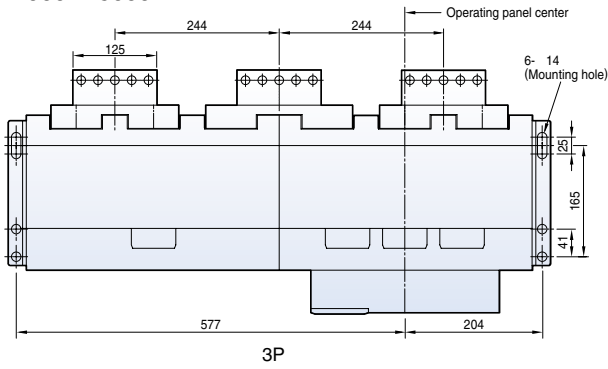

### 6300A

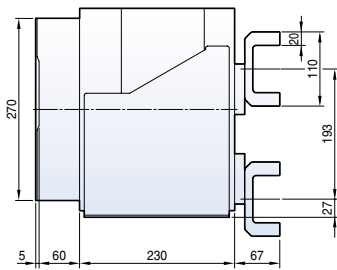
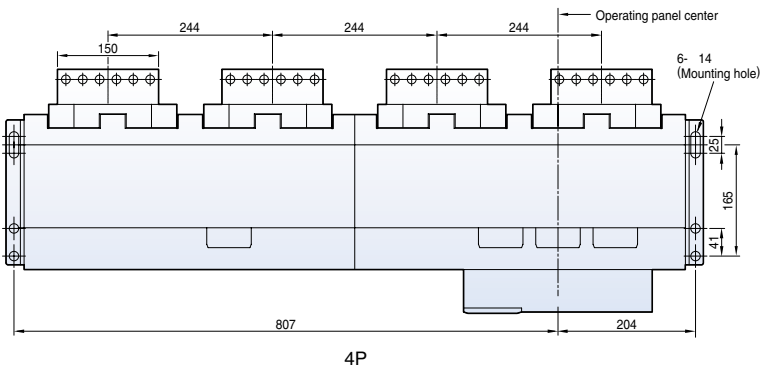
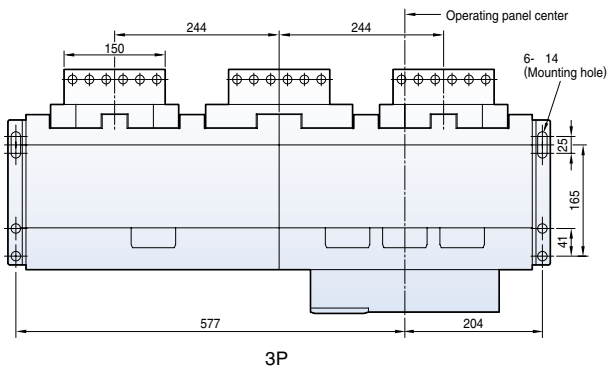

# Dimensions

Susol

## Draw-out type 6300AF (4000A~6300A)

### Front view

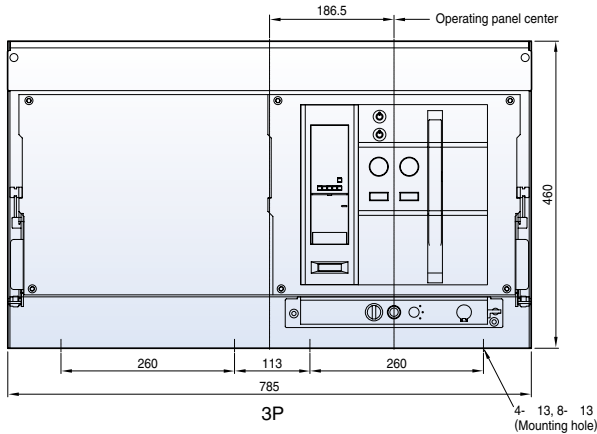

4000A~5000A

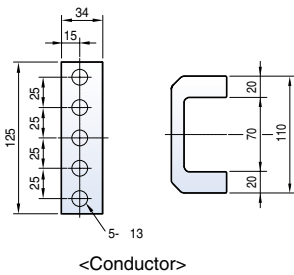

<Conductor>

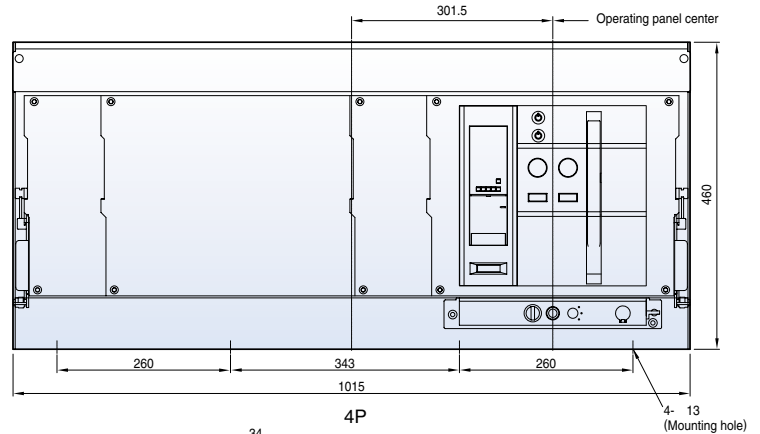

6300A

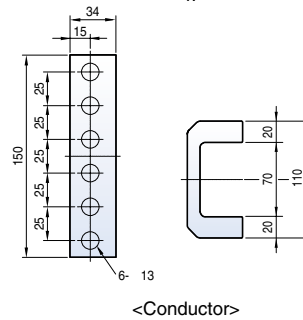

<Conductor>

### Vertical type

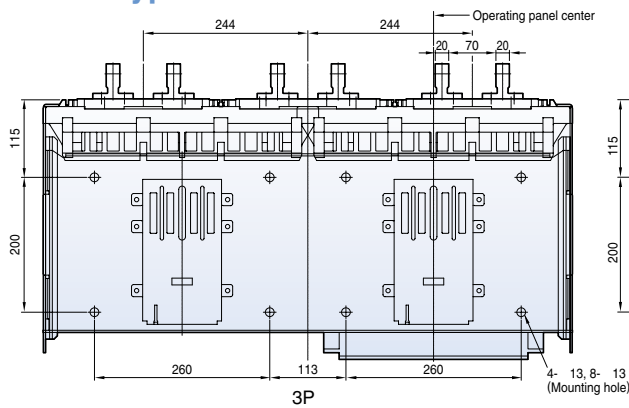

4000A~5000A

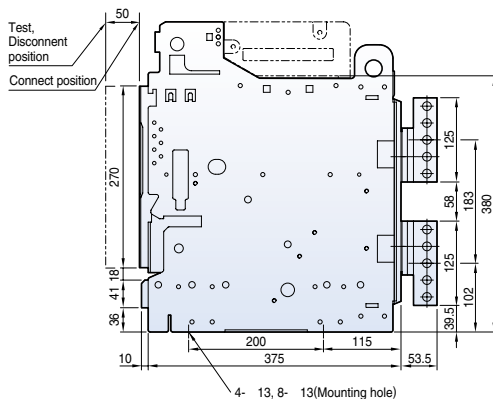

4- 13, 8- 13(Mounting hole)

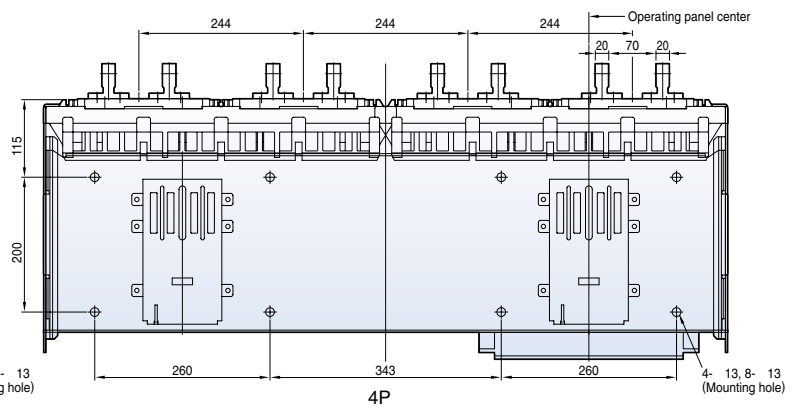

6300A

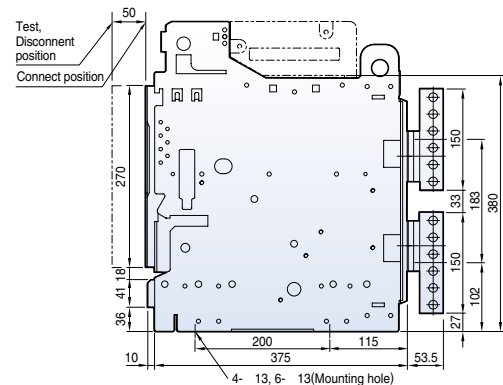

4- 13, 6- 13(Mounting hole)

## Horizontal type

### 4000A~5000A

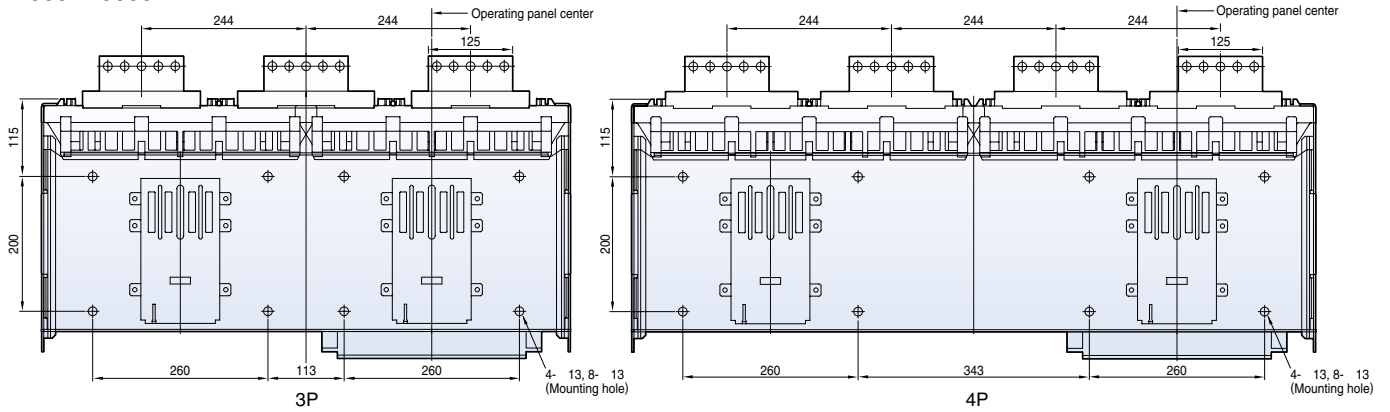

### 6300A

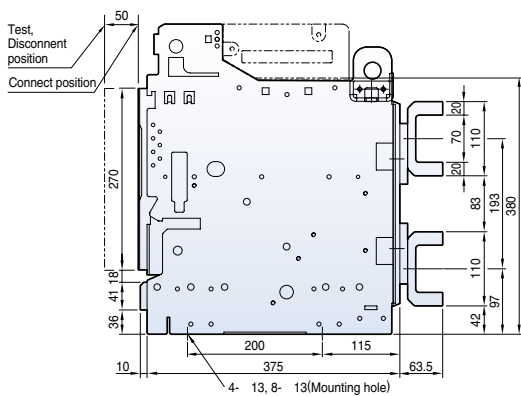
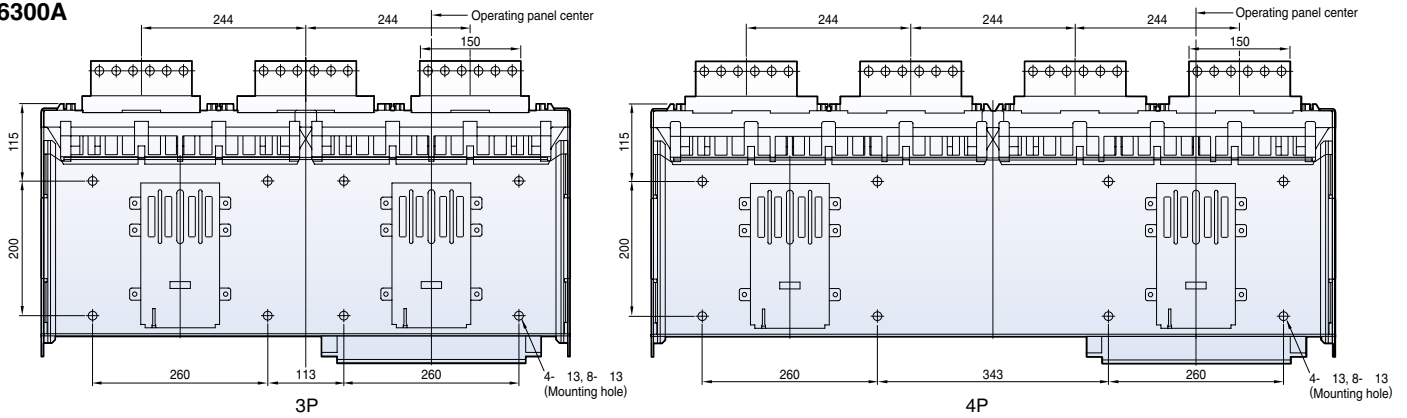

# Technical information

Susol

## Insulation voltage

You should keep the isolation distance between ACB and panel as below table.

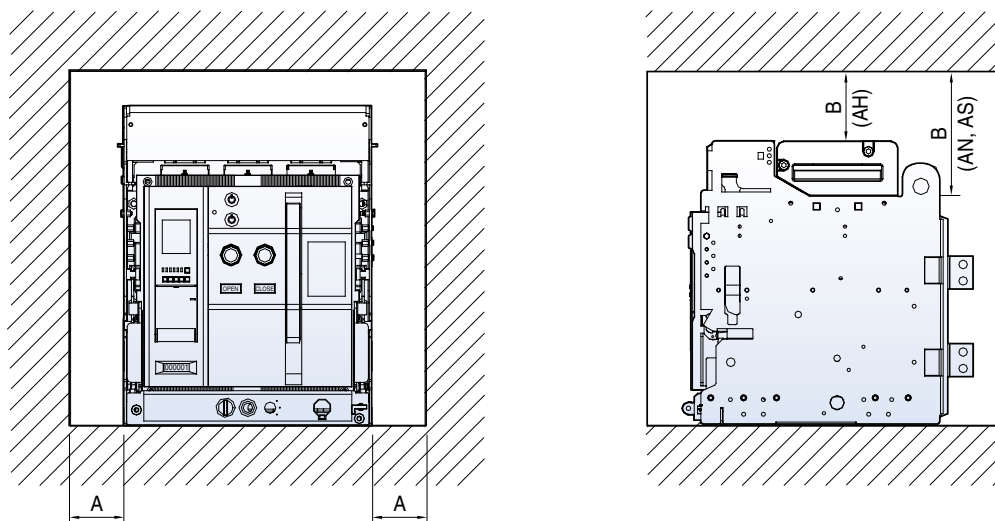

Type		A	B
Fixed	AN/AS	50	150
	AH	50	0
Draw out	AN/AS	50	150
	AH	50	0

Note) When drawing the distribution panel, it is available to use regardless of the distance between ACB and the wall of the panel because Susol ACB(draw-in/out type) extinguishes the arc in the Arc Chute and Arc Cover clearly.

## Minimum isolation distance

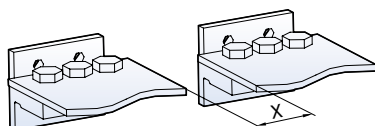

For the safety, all the electric charging parts need to be installed over minimum isolation distance.



Insulating voltage (Ui)	Minimum isolation distance (X min)
600V	8 mm
1000V	14 mm

## Temperature derating

The table below indicates the maximum current rating, for each connection type, as a function of the ambient temperature around the circuit breaker and the busbars. Circuit breakers with mixed connections have the same derating as horizontally connected breakers. For ambient temperatures greater than 60°C, consult us. Temperature inside the switchboard around the circuit breaker and its connection: T<sub>i</sub>(IEC 60947-2)

Frame	Rated current	ACB terminal	Applicable busbar size											
				Horizontal type					Vertical type					
				40 °C	45 °C	50 °C	55 °C	60 °C	40 °C	45 °C	50 °C	55 °C	60 °C	
2,000AF AH-D AS-D AN-D	200A	15t×30×1ea	5t×30×2ea	200A	200A	200A	200A	200A	200A	200A	200A	200A	200A	200A
	400A			400A	400A	400A	400A	400A	400A	400A	400A	400A	400A	400A
	630A		5t×40×2ea	630A	630A	630A	630A	630A	630A	630A	630A	630A	630A	630A
	800A		5t×50×2ea	800A	800A	800A	800A	800A	800A	800A	800A	800A	800A	800A
	1,000A		5t×60×2ea	1,000A	1,000A	1,000A	1,000A	1,000A	1,000A	1,000A	1,000A	1,000A	1,000A	1,000A
	1,250A		5t×80×2ea	1,250A	1,250A	1,250A	1,250A	1,250A	1,250A	1,250A	1,250A	1,250A	1,250A	1,250A
	1,600A		5t×100×2ea	1,600A	1,600A	1,600A	1,550A	1,550A	1,600A	1,600A	1,600A	1,600A	1,600A	1,550A
	2,000A	15t×75×1ea	5t×100×3ea	-	-	-	-	-	2,000A	2,000A	2,000A	1,950A	1,900A	
4,000AF AH-E AS-E	630A	20t×75×1ea	5t×40×2ea	630A	630A	630A	630A	630A	630A	630A	630A	630A	630A	
	800A		5t×50×2ea	800A	800A	800A	800A	800A	800A	800A	800A	800A	800A	
	1,000A		5t×60×2ea	1,000A	1,000A	1,000A	1,000A	1,000A	1,000A	1,000A	1,000A	1,000A	1,000A	
	1,250A		5t×80×2ea	1,250A	1,250A	1,250A	1,250A	1,250A	1,250A	1,250A	1,250A	1,250A	1,250A	
	1,600A		5t×100×2ea	1,600A	1,600A	1,600A	1,600A	1,600A	1,600A	1,600A	1,600A	1,600A	1,600A	
	2,000A		5t×100×3ea	2,000A	2,000A	2,000A	2,000A	2,000A	2,000A	2,000A	2,000A	2,000A	2,000A	
	2,500A		5t×100×4ea	2,500A	2,500A	2,500A	2,400A	2,300A	2,500A	2,500A	2,500A	2,500A	2,450A	2,350A
	3,200A	10t×100×3ea	3,200A	3,200A	3,100A	3,000A	2,900A	3,200A	3,200A	3,150A	3,050A	3,950A		
	4,000A	10t×100×3ea	10t×100×4ea	4,000A	3,900A	3,800A	3,700A	3,600A	4,000A	3,950A	3,850A	3,750A	3,650A	
5,000AF AS-F	4,000A	20t×125×2ea	10t×100×4ea	4,000A	3,900A	3,800A	3,700A	3,600A	4,000A	3,950A	3,850A	3,750A	3,650A	
	5,000A		10t×125×4ea	5,000A	5,000A	4,900A	4,800A	4,700A	5,000A	5,000A	4,950A	4,850A	4,750A	
6,300AF AH-G AS-G	4,000A	20t×125×2ea	10t×100×4ea	4,000A	4,000A	4,000A	3,900A	3,800A	4,000A	4,000A	4,000A	3,950A	3,850A	
	5,000A		10t×125×4ea	5,000A	5,000A	5,000A	4,900A	4,800A	5,000A	5,000A	5,000A	4,950A	4,850A	
	6,300A	20t×150×2ea	10t×150×4ea	6,300A	6,300A	6,200A	6,100A	6,000A	6,300A	6,300A	6,250A	6,152A	6,050A	

## Operating conditions

### Ambient temperature

ACB devices can operate under the following temperature conditions

- The electrical and mechanical characteristics are stipulated for an ambient temperature of -5°C to +40°C
- The average temperature should be within + 35°C
- Reduce the continuous conducting current when the temperature is over 45°C (refer to temperature derating)
- Storage condition : -20°C to + 60°C is recommended.

### Altitude

Susol ACB is designed for operation at altitudes under 2000m.

At altitudes higher than 2000m, emitting heat is lowered and operating voltage, continuous current capacity, and breaking capacity will be reduced.

Durability of the insulation is also reduced according to the atmosphere pressure.

According to the below table, change the ratings upon a service condition.

Item	Altitude [m]			
	2000m	3000m	4000m	5000m
Withstand voltage [V]	3500	3150	2500	2100
Average insulating voltage [v]	1000	900	700	600
Max. using voltage [V]	690	590	520	460
Current compensation constant	$1 \times I_n$	$0.99 \times I_n$	$0.96 \times I_n$	$0.94 \times I_n$

### Environment

Under clean air;

Maximum temperature + 40°C (relative humidity should be under 85%)

Maximum temperature + 20°C (relative humidity should be under 90%)

Do not apply under corrosive or ammonia gas circumstances

( $H_2S \leq 0.01\text{ppm}$ ,  $SO_2 \leq 0.01\text{ppm}$ ,  $NH_3 \leq \text{a few ppm}$ )

#### \* Extreme atmosphere conditions

Under high temperature and/or high humidity, the insulation durability, electrical and mechanical features could be deteriorated. At this conditions, increasing corrosion-resistant dealing needs. Corrosion-resistant parts need under this conditions.



## Protective coordination

Rated voltage: AC 220/240V

Main breaker(Main ACB): Susol ACB

Downstream breaker(Downstream MCCB): Susol MCCB TD/TS series

Below protective coordination table is based on ACB equipped with OCR under arrangement of short time delay trip current as 10 times of rated current.

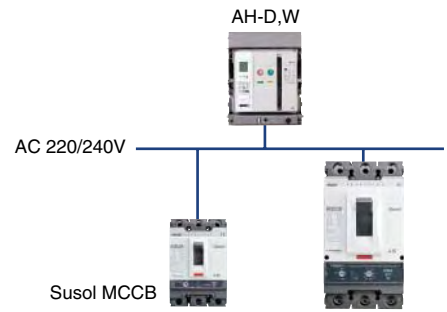

Downstream breaker			Product type	Susol AH series									
				AH-D,W									
				AH-06D			AH-08D			AH-10D	AH-13D	AH-16D	AH-20D
				Rated current [A]	200	400	630	400	630	800	1000	1250	1600
Short time delay trip current (Max. 10In) Is [kA]			2	4	6.3	4	6.3	8	10	12.5	16	20	
Model	Rated current [A]	Ultimate breaking capacity Icu [kA]	85										
Susol MCCB	TD100N	100	85	-	4	9	4	9	17	29	50	T	T
	TD100H	100	100	-	4	9	4	9	17	29	50	85	T
	TD100L	100	200	-	4	9	4	9	17	29	50	85	180
	TD160N	160	85	-	4	9	4	9	17	29	50	T	T
	TD160H	160	100	-	4	9	4	9	17	29	50	85	T
	TD160L	160	200	-	4	9	4	9	17	29	50	85	180
	TS100N	100	100	-	4	7	4	7	12	20	35	60	T
	TS100H	100	120	-	4	7	4	7	12	20	35	60	100
	TS100L	100	200	-	4	7	4	7	12	20	35	60	100
	TS160N	160	100	-	4	7	4	7	12	20	35	60	T
	TS160H	160	120	-	4	7	4	7	12	20	35	60	100
	TS160L	160	200	-	4	7	4	7	12	20	35	60	100
	TS250N	250	100	-	4	7	4	7	12	20	35	60	T
	TS250H	250	120	-	4	7	4	7	12	20	35	60	100
	TS250L	250	200	-	4	7	4	7	12	20	35	60	100
	TS400N	400	100	-	-	-	-	-	8	10	12.5	16	20
	TS400H	400	120	-	-	-	-	-	8	10	12.5	16	20
	TS400L	400	200	-	-	-	-	-	8	10	12.5	16	20
	TS630N	630	100	-	-	-	-	-	8	10	12.5	16	20
	TS630H	500	120	-	-	-	-	-	8	10	12.5	16	20
630		-		-	-	-	-	8	10	12.5	16	20	
TS630L	500	200	-	-	-	-	-	8	10	12.5	16	20	
	630		-	-	-	-	-	8	10	12.5	16	20	
TS800N	700	100	-	-	-	-	-	-	10	12.5	16	20	
	800		-	-	-	-	-	-	10	12.5	16	20	
TS800H	700	120	-	-	-	-	-	-	10	12.5	16	20	
	800		-	-	-	-	-	-	10	12.5	16	20	
TS800L	700	200	-	-	-	-	-	-	10	12.5	16	20	
	800		-	-	-	-	-	-	10	12.5	16	20	

Note) 1. On table, protective coordination is not available for areas where number is missing.  
 2. On table, marked number is breaking capacity limit (Unit: kA) for protective coordination.  
 3. On table, areas that is marked as T are capable of total discrimination up to its Downstream breaker's rated short breaking capacity.

# Technical information

Susol

## Protective coordination

Rated voltage: AC 220/240V

Main breaker(Main ACB): Susol ACB

Downstream breaker(Downstream MCCB): Susol MCCB TD/TS series

Below protective coordination table is based on ACB equipped with OCR under arrangement of short time delay trip current as 10 times of rated current.

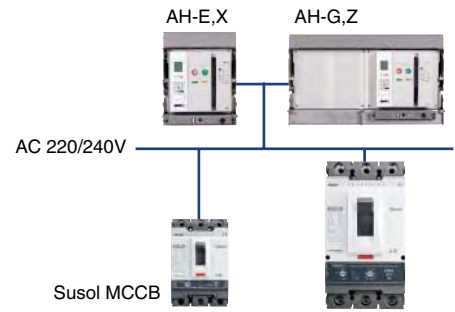

Upstream breaker		Product type	Susol AH series													
			AH-E,X										AH-G,Z			
			AH-06E		AH-08E	AH-10E	AH-13E	AH-16E	AH-20E	AH-25E	AH-32E	AH-40E	AH-40G	AH-50G	AH-63G	
Downstream breaker	Rated current [A]	400	630	800	1000	1250	1600	2000	2500	3200	4000	4000	5000	6300		
	Short time delay trip current (Max. 10In) Is[kA]	4	6.3	8	10	12.5	16	20	25	32	40	40	50	63		
Model	Rated current [A]	Ultimate breaking capacity Icu [kA]	100										150			
Susol MCCB	TD100N	100	85	4	9	17	29	50	T	T	T	T	T	T	T	T
	TD100H	100	100	4	9	17	29	50	85	T	T	T	T	T	T	T
	TD100L	100	200	4	9	17	29	50	85	180	T	T	T	T	T	T
	TD160N	160	85	4	9	17	29	50	T	T	T	T	T	T	T	T
	TD160H	160	100	4	9	17	29	50	85	T	T	T	T	T	T	T
	TD160L	160	200	4	9	17	29	50	85	180	T	T	T	T	T	T
	TS100N	100	100	4	7	12	20	35	60	T	T	T	T	T	T	T
	TS100H	100	120	4	7	12	20	35	60	100	T	T	T	T	T	T
	TS100L	100	200	4	7	12	20	35	60	100	T	T	T	T	T	T
	TS160N	160	100	4	7	12	20	35	60	T	T	T	T	T	T	T
	TS160H	160	120	4	7	12	20	35	60	100	T	T	T	T	T	T
	TS160L	160	200	4	7	12	20	35	60	100	T	T	T	T	T	T
	TS250N	250	100	4	7	12	20	35	60	T	T	T	T	T	T	T
	TS250H	250	120	4	7	12	20	35	60	100	T	T	T	T	T	T
	TS250L	250	200	4	7	12	20	35	60	100	T	T	T	T	T	T
	TS400N	400	100	-	-	8	10	12.5	16	20	30	50	T	T	T	T
	TS400H	400	120	-	-	8	10	12.5	16	20	30	50	T	T	T	T
	TS400L	400	200	-	-	8	10	12.5	16	20	30	50	120	120	T	T
	TS630N	630	100	-	-	8	10	12.5	16	20	30	50	T	T	T	T
	TS630H	500	120	-	-	8	10	12.5	16	20	30	50	T	T	T	T
		630		-	-	8	10	12.5	16	20	30	50	T	T	T	T
	TS630L	500	200	-	-	8	10	12.5	16	20	30	50	120	120	T	T
		630		-	-	8	10	12.5	16	20	30	50	120	120	T	T
	TS800N	700	100	-	-	-	10	12.5	16	20	25	32	50	50	T	T
800		-		-	-	10	12.5	16	20	25	32	50	50	T	T	
TS800H	700	120	-	-	-	10	12.5	16	20	25	32	50	50	T	T	
	800		-	-	-	10	12.5	16	20	25	32	50	50	T	T	
TS800L	700	200	-	-	-	10	12.5	16	20	25	32	50	50	120	T	
	800		-	-	-	10	12.5	16	20	25	32	50	50	120	T	

Note) 1. On table, protective coordination is not available for areas where number is missing.

2. On table, marked number is breaking capacity limit (Unit: kA) for protective coordination.

3. On table, areas that is marked as T are capable of total discrimination up to its Downstream breaker's rated short breaking capacity.

Rated voltage: AC 380/415V  
 Main breaker(Main ACB): Susol ACB  
 Downstream breaker(Downstream MCCB): Susol MCCB TD/TS series  
 Below protective coordination table is based on ACB equipped with OCR under arrangement of short time delay trip current as 10 times of rated current.

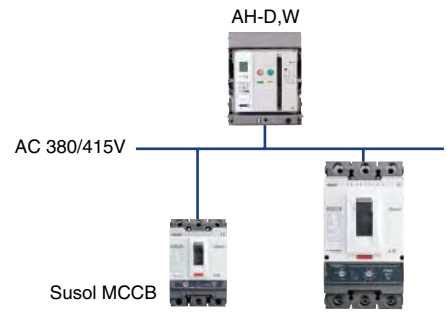

Downstream breaker		Upstream breaker		Product type	Susol AH series											
					AH-D,W											
							AH-06D			AH-08D			AH-10D	AH-13D	AH-16D	AH-20D
				Model	Rated current [A]	Ultimate breaking capacity Icu [kA]	200	400	630	400	630	800	1000	1250	1600	2000
					85											
Susol MCCB	TD100N	100	50	-	4	6.3	4	6.3	9	13.5	22	38	T			
	TD100H	100	85	-	4	6.3	4	6.3	9	13.5	22	38	60			
	TD100L	100	150	-	4	6.3	4	6.3	9	13.5	22	38	60			
	TD160N	160	50	-	4	6.3	4	6.3	9	13.5	22	38	T			
	TD160H	160	85	-	4	6.3	4	6.3	9	13.5	22	38	60			
	TD160L	160	150	-	4	6.3	4	6.3	9	13.5	22	38	60			
	TS100N	100	50	-	4	6.3	4	6.3	8	10	15	26	43			
	TS100H	100	85	-	4	6.3	4	6.3	8	10	15	26	43			
	TS100L	100	150	-	4	6.3	4	6.3	8	10	15	26	43			
	TS160N	160	50	-	4	6.3	4	6.3	8	10	15	26	43			
	TS160H	160	85	-	4	6.3	4	6.3	8	10	15	26	43			
	TS160L	160	150	-	4	6.3	4	6.3	8	10	15	26	43			
	TS250N	250	50	-	4	6.3	4	6.3	8	10	15	26	43			
	TS250H	250	85	-	4	6.3	4	6.3	8	10	15	26	43			
	TS250L	250	150	-	4	6.3	4	6.3	8	10	15	26	43			
	TS400N	400	65	-	-	-	-	-	8	10	12.5	16	20			
	TS400H	400	85	-	-	-	-	-	8	10	12.5	16	20			
	TS400L	400	150	-	-	-	-	-	8	10	12.5	16	20			
	TS630N	630	65	-	-	-	-	-	8	10	12.5	16	20			
	TS630H	500	85	-	-	-	-	-	8	10	12.5	16	20			
630		-		-	-	-	-	8	10	12.5	16	20				
TS630L	500	150	-	-	-	-	-	8	10	12.5	16	20				
	630		-	-	-	-	-	8	10	12.5	16	20				
TS800N	700	65	-	-	-	-	-	-	10	12.5	16	20				
	800		-	-	-	-	-	-	10	12.5	16	20				
TS800H	700	100	-	-	-	-	-	-	10	12.5	16	20				
	800		-	-	-	-	-	-	10	12.5	16	20				
TS800L	700	150	-	-	-	-	-	-	10	12.5	16	20				
	800		-	-	-	-	-	-	10	12.5	16	20				

Note) 1. On table, protective coordination is not available for areas where number is missing.  
 2. On table, marked number is breaking capacity limit (Unit: kA) for protective coordination.  
 3. On table, areas that is marked as T are capable of total discrimination up to its Downstream breaker's rated short breaking capacity.

# Technical information

Susol

## Protective coordination

Rated voltage: AC 380/415V

Main breaker(Main ACB): Susol ACB

Downstream breaker(Downstream MCCB): Susol MCCB TD/TS series

Below protective coordination table is based on ACB equipped with OCR under arrangement of short time delay trip current as 10 times of rated current.

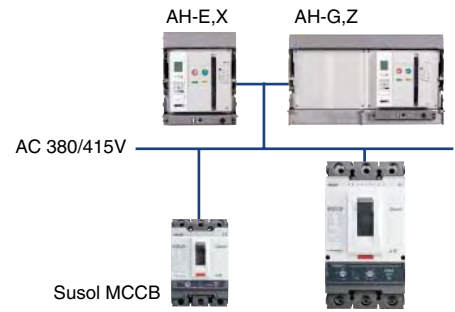

Upstream breaker		Product type	Susol AH series													
			AH-E,X										AH-G,Z			
			AH-06E		AH-08E	AH-10E	AH-13E	AH-16E	AH-20E	AH-25E	AH-32E	AH-40E	AH-40G	AH-50G	AH-63G	
Downstream breaker	Rated current [A]	400	630	800	1000	1250	1600	2000	2500	3200	4000	4000	5000	6300		
	Short time delay trip current (Max. 10In) Is[kA]	4	6.3	8	10	12.5	16	20	25	32	40	40	50	63		
Model	Rated current [A]	Ultimate breaking capacity Icu [kA]	100										150			
Susol MCCB	TD100N	100	50	4	6.3	9	13.5	22	38	T	T	T	T	T	T	T
	TD100H	100	85	4	6.3	9	13.5	22	38	60	T	T	T	T	T	T
	TD100L	100	150	4	6.3	9	13.5	22	38	60	120	T	T	T	T	T
	TD160N	160	50	4	6.3	9	13.5	22	38	T	T	T	T	T	T	T
	TD160H	160	85	4	6.3	9	13.5	22	38	60	T	T	T	T	T	T
	TD160L	160	150	4	6.3	9	13.5	22	38	60	120	T	T	T	T	T
	TS100N	100	50	4	6.3	8	10	15	26	43	T	T	T	T	T	T
	TS100H	100	85	4	6.3	8	10	15	26	43	70	T	T	T	T	T
	TS100L	100	150	4	6.3	8	10	15	26	43	70	120	T	T	T	T
	TS160N	160	50	4	6.3	8	10	15	26	43	T	T	T	T	T	T
	TS160H	160	85	4	6.3	8	10	15	26	43	70	T	T	T	T	T
	TS160L	160	150	4	6.3	8	10	15	26	43	70	120	T	T	T	T
	TS250N	250	50	4	6.3	8	10	15	26	43	T	T	T	T	T	T
	TS250H	250	85	4	6.3	8	10	15	26	43	70	T	T	T	T	T
	TS250L	250	150	4	6.3	8	10	15	26	43	70	120	T	T	T	T
	TS400N	400	65	-	-	8	10	12.5	16	20	25	35	T	T	T	T
	TS400H	400	85	-	-	8	10	12.5	16	20	25	35	65	65	T	T
	TS400L	400	150	-	-	8	10	12.5	16	20	25	35	65	65	130	T
	TS630N	630	65	-	-	8	10	12.5	16	20	25	35	T	T	T	T
	TS630H	500	85	-	-	8	10	12.5	16	20	25	35	65	65	T	T
630		-		-	8	10	12.5	16	20	25	35	65	65	T	T	
TS630L	500	150	-	-	8	10	12.5	16	20	25	35	65	65	130	T	
	630		-	-	8	10	12.5	16	20	25	35	65	65	130	T	
TS800N	700	65	-	-	-	10	12.5	16	20	25	32	40	40	T	T	
	800		-	-	-	10	12.5	16	20	25	32	40	40	T	T	
TS800H	700	100	-	-	-	10	12.5	16	20	25	32	40	40	65	T	
	800		-	-	-	10	12.5	16	20	25	32	40	40	65	T	
TS800L	700	150	-	-	-	10	12.5	16	20	25	32	40	40	65	110	
	800		-	-	-	10	12.5	16	20	25	32	40	40	65	110	

Note) 1. On table, protective coordination is not available for areas where number is missing.

2. On table, marked number is breaking capacity limit (Unit: kA) for protective coordination.

3. On table, areas that is marked as T are capable of total discrimination up to its Downstream breaker's rated short breaking capacity.

Rated voltage: AC 480/500V  
 Main breaker(Main ACB): Susol ACB  
 Downstream breaker(Downstream MCCB): Susol MCCB TD/TS series  
 Below protective coordination table is based on ACB equipped with OCR under arrangement of short time delay trip current as 10 times of rated current.

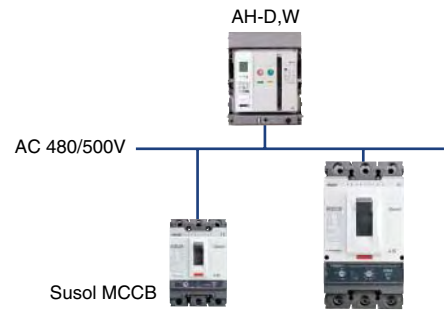

Downstream breaker			Product type	Susol AH series									
				AH-D,W									
				AH-06D			AH-08D			AH-10D	AH-13D	AH-16D	AH-20D
				Rated current [A]	200	400	630	400	630	800	1000	1250	1600
Short time delay trip current (Max. 10In) Is [kA]			2	4	6.3	4	6.3	8	10	12.5	16	20	
Model	Rated current [A]	Ultimate breaking capacity Icu [kA]	85										
Susol MCCB	TD100N	100	30	-	4	6.3	4	6.3	8	10	17	T	T
	TD100H	100	50	-	4	6.3	4	6.3	8	10	17	30	T
	TD100L	100	65	-	4	6.3	4	6.3	8	10	17	30	55
	TD160N	160	30	-	4	6.3	4	6.3	8	10	17	T	T
	TD160H	160	50	-	4	6.3	4	6.3	8	10	17	30	T
	TD160L	160	65	-	4	6.3	4	6.3	8	10	17	30	55
	TS100N	100	42	-	4	6.3	4	6.3	8	10	14	25	T
	TS100H	100	65	-	4	6.3	4	6.3	8	10	14	25	42.5
	TS100L	100	85	-	4	6.3	4	6.3	8	10	14	25	42.5
	TS160N	160	42	-	4	6.3	4	6.3	8	10	14	25	T
	TS160H	160	65	-	4	6.3	4	6.3	8	10	14	25	42.5
	TS160L	160	85	-	4	6.3	4	6.3	8	10	14	25	42.5
	TS250N	250	42	-	4	6.3	4	6.3	8	10	14	25	T
	TS250H	250	65	-	4	6.3	4	6.3	8	10	14	25	42.5
	TS250L	250	85	-	4	6.3	4	6.3	8	10	14	25	42.5
	TS400N	400	42	-	-	-	-	-	8	10	12.5	16	20
	TS400H	400	65	-	-	-	-	-	8	10	12.5	16	20
	TS400L	400	85	-	-	-	-	-	8	10	12.5	16	20
	TS630N	630	42	-	-	-	-	-	8	10	12.5	16	20
	TS630H	500	65	-	-	-	-	-	8	10	12.5	16	20
630		-		-	-	-	-	8	10	12.5	16	20	
TS630L	500	85	-	-	-	-	-	8	10	12.5	16	20	
	630		-	-	-	-	-	8	10	12.5	16	20	
TS800N	700	42	-	-	-	-	-	-	10	12.5	16	20	
	800		-	-	-	-	-	-	10	12.5	16	20	
TS800H	700	85	-	-	-	-	-	-	10	12.5	16	20	
	800		-	-	-	-	-	-	10	12.5	16	20	
TS800L	700	100	-	-	-	-	-	-	10	12.5	16	20	
	800		-	-	-	-	-	-	10	12.5	16	20	

Note) 1. On table, protective coordination is not available for areas where number is missing.  
 2. On table, marked number is breaking capacity limit (Unit: kA) for protective coordination.  
 3. On table, areas that is marked as T are capable of total discrimination up to its Downstream breaker's rated short breaking capacity.

# Technical information

**Susol**

Rated voltage: AC 480/500V

Main breaker(Main ACB): Susol ACB

Downstream breaker(Downstream MCCB): Susol MCCB TD/TS series

Below protective coordination table is based on ACB equipped with OCR under arrangement of short time delay trip current as 10 times of rated current.

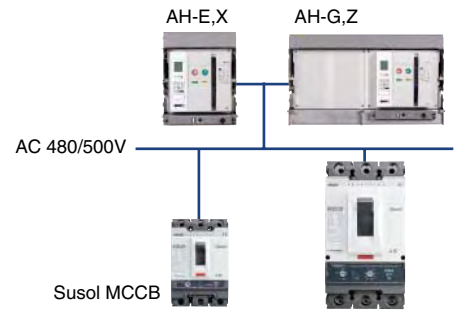

Upstream breaker		Product type	Susol AH series												
			AH-E,X										AH-G,Z		
			AH-06E	AH-08E	AH-10E	AH-13E	AH-16E	AH-20E	AH-25E	AH-32E	AH-40E	AH-40G	AH-50G	AH-63G	
Downstream breaker	Rated current [A]	400	630	800	1000	1250	1600	2000	2500	3200	4000	4000	5000	6300	
	Short time delay trip current (Max. 10In) Is[kA]	4	6.3	8	10	12.5	16	20	25	32	40	40	50	63	
Model	Rated current [A]	Ultimate breaking capacity Icu [kA]	100										150		
Susol MCCB	TD100H	100	50	4	6.3	8	10	17	T	T	T	T	T	T	T
	TD100L	100	65	4	6.3	8	10	17	30	T	T	T	T	T	T
	TD160N	160	30	4	6.3	8	10	17	30	55	T	T	T	T	T
	TD160H	160	50	4	6.3	8	10	17	T	T	T	T	T	T	T
	TD160L	160	65	4	6.3	8	10	17	30	T	T	T	T	T	T
	TS100N	100	42	4	6.3	8	10	17	30	55	T	T	T	T	T
	TS100H	100	65	4	6.3	8	10	14	25	T	T	T	T	T	T
	TS100L	100	85	4	6.3	8	10	14	25	42.5	T	T	T	T	T
	TS160N	160	42	4	6.3	8	10	14	25	42.5	70	T	T	T	T
	TS160H	160	65	4	6.3	8	10	14	25	T	T	T	T	T	T
	TS160L	160	85	4	6.3	8	10	14	25	42.5	T	T	T	T	T
	TS250N	250	42	4	6.3	8	10	14	25	42.5	70	T	T	T	T
	TS250H	250	65	4	6.3	8	10	14	25	T	T	T	T	T	T
	TS250L	250	85	4	6.3	8	10	14	25	42.5	T	T	T	T	T
	TS400N	400	42	4	6.3	8	10	14	25	42.5	70	T	T	T	T
	TS400H	400	65	-	-	8	10	12.5	16	20	25	32	T	T	T
	TS400L	400	85	-	-	8	10	12.5	16	20	25	32	52.5	52.5	T
	TS630N	630	42	-	-	8	10	12.5	16	20	25	32	52.5	52.5	T
	TS630N	630	42	-	-	8	10	12.5	16	20	25	32	T	T	T
	TS630H	500	65	-	-	8	10	12.5	16	20	25	32	52.5	52.5	T
		630		-	-	8	10	12.5	16	20	25	32	52.5	52.5	T
	TS630L	500	85	-	-	8	10	12.5	16	20	25	32	52.5	52.5	T
		630		-	-	8	10	12.5	16	20	25	32	52.5	52.5	T
	TS800N	700	42	-	-	-	10	12.5	16	20	25	32	40	40	T
800		-		-	-	10	12.5	16	20	25	32	40	40	T	
TS800H	700	85	-	-	-	10	12.5	16	20	25	32	40	40	55	
	800		-	-	-	10	12.5	16	20	25	32	40	40	55	
TS800L	700	100	-	-	-	10	12.5	16	20	25	32	40	40	55	
	800		-	-	-	10	12.5	16	20	25	32	40	40	55	

Note) 1. On table, protective coordination is not available for areas where number is missing.

2. On table, marked number is breaking capacity limit (Unit: kA) for protective coordination.

3. On table, areas that is marked as T are capable of total discrimination up to its Downstream breaker's rated short breaking capacity.

# Standards & Approval

Susol



## AH, AS, AN series Air Circuit Breakers comply with the following international standard;

### IEC 60947-1

Low-voltage switchgear and controlgear  
- Part 1: General rules

### IEC 60947-2

Low-voltage switchgear and controlgear  
- Part 2: Circuit-breakers

The following certificates are available on a request.

- CE Declaration of conformity
- Certificate of conformance test (CB) - IEC 60947
- Full type test report issued by KEMA
- Letter of origin

## CE conformity marking

The CE conformity marking shall indicate conformity to all the obligations imposed on the manufacturer, as regards his products, by virtue of the European Community directives providing for the affixing of the CE marking.

When the CE marking is affixed on a product, it represents a declaration of the manufacturer or of his authorized representative that the product in question conforms to all the applicable provisions including the conformity assessment procedures. This prevents the Member States from limiting the marketing and putting into service of products bearing the CE marking, unless this measure is justified by the proved non-conformity of the product.

## IECEE CB SCHEME

The IECEE CB Scheme is the world's first truly international system for acceptance of test reports dealing with the safety of electrical and electronic products. It is a multilateral agreement among participating countries and certification organizations. A manufacturer utilizing a CB test report issued by one of these organizations can obtain national certification in all other member countries of the CB Scheme.

The Scheme is based on the use of international (IEC) Standards. If some members' national standards are not yet completely harmonized with IEC Standards, national differences are permitted if clearly declared to all other members. The CB Scheme utilizes CB Test Certificates to attest that product samples have successfully passed the appropriate tests and are in compliance with the requirements of the relevant IEC Standard and with the declared national differences of various member countries.

The main objective of the Scheme, is to facilitate trade by promoting harmonization of the national standards with international Standards and cooperation among product certifiers worldwide in order to bring product manufacturers a step closer to the ideal concept of "one product, one test, one mark, where applicable".



# Time chart

Susol

## Long time

x/lr \ tr	0.5	1	2	4	8	12	16	20
1.11	58806	117611	235223	470445	940890	1411335	1881780	2352225
1.15	36041	72082	144163	288326	576652	864978	1153305	1441631
1.20	26827	53654	107308	214615	429231	643846	858461	1073077
1.25	21777	43553	87106	174212	348424	522636	696848	871060
1.30	18408	36817	73634	147268	294535	441803	589071	736338
1.35	15947	31895	63789	127579	255157	382736	510314	637893
1.40	14049	28098	56197	112393	224787	337180	449573	561967
1.45	12532	25063	50126	100252	200504	300756	401009	501261
1.50	11286	22573	45145	90290	180580	270870	361160	451450
1.55	10244	20488	40977	81954	163907	245861	327814	409768
1.60	9359	18717	37434	74869	149737	224606	299474	374343
1.65	8596	17193	34386	68771	137542	206313	275084	343855
1.70	7934	15867	31734	63468	126936	190404	253873	317341
1.75	7352	14704	29408	58815	117631	176446	235261	294077
1.80	6838	13675	27351	54702	109404	164106	218808	273509
1.85	6380	12760	25521	51041	102082	153123	204164	255205
1.90	5970	11941	23882	47764	95528	143292	191056	238820
1.95	5602	11204	22408	44815	89630	134446	179261	224076
2.00	5269	10537	21075	42150	84299	126449	168598	210748
2.05	4966	9932	19865	39730	79459	119189	158919	198649
2.10	4691	9381	18762	37525	75049	112574	150099	187623
2.15	4439	8877	17754	35508	71017	106525	142034	177542
2.20	4207	8415	16829	33659	67318	100976	134635	168294
2.25	3995	7989	15979	31957	63914	95871	127829	159786
2.30	3798	7597	15194	30387	60775	91162	121550	151937
2.35	3617	7234	14468	28936	57871	86807	115742	144678
2.40	3449	6897	13795	27590	55180	82769	110359	137949
2.45	3292	6585	13170	26339	52679	79018	105358	131697
2.50	3147	6294	12588	25176	50351	75527	100702	125878
2.55	3011	6022	12045	24090	48180	72269	96359	120449
2.60	2884	5769	11538	23075	46151	69226	92301	115377
2.65	2766	5531	11063	22126	44251	66377	88503	110628
2.70	2654	5309	10618	21235	42471	63706	84941	106177
2.75	2550	5100	10200	20399	40799	61198	81597	101997
2.80	2452	4903	9807	19613	39226	58840	78453	98066
2.85	2359	4718	9436	18873	37746	56619	75491	94364
2.90	2272	4544	9087	18175	36350	54524	72699	90874
2.95	2189	4379	8758	17516	35032	52547	70063	87579
3.00	2112	4223	8446	16893	33786	50679	67572	84464
3.05	2038	4076	8152	16303	32607	48910	65214	81517
3.10	1968	3936	7872	15745	31490	47235	62980	78725
3.15	1902	3804	7608	15215	30431	45646	60862	76077
3.20	1839	3678	7356	14713	29425	44138	58851	73563
3.25	1779	3559	7117	14235	28470	42705	56940	71175
3.30	1723	3445	6890	13781	27561	41342	55122	68903
3.35	1669	3337	6674	13348	26696	40044	53392	66741
3.40	1617	3234	6468	12936	25872	38808	51744	64680
3.45	1568	3136	6272	12543	25086	37629	50172	62715
3.50	1521	3042	6084	12168	24336	36504	48672	60841
3.55	1476	2952	5905	11810	23620	35430	47240	59050
3.60	1433	2867	5734	11468	22935	34403	45871	57338
3.65	1393	2785	5570	11140	22281	33421	44561	55702
3.70	1353	2707	5413	10827	21654	32481	43308	54135
3.75	1316	2632	5263	10527	21054	31581	42108	52634
3.80	1280	2560	5120	10239	20479	30718	40957	51196
3.85	1245	2491	4982	9963	19927	29890	39854	49817
3.90	1212	2425	4849	9699	19398	29096	38795	48494

x/lr \ tr	0.5	1	2	4	8	12	16	20
3.95	1181	2361	4722	9445	18889	28334	37779	47223
4.00	1150	2300	4600	9201	18401	27602	36802	46003
4.05	1121	2241	4483	8966	17932	26898	35864	44830
4.10	1093	2185	4370	8740	17481	26221	34961	43701
4.15	1065	2131	4262	8523	17046	25569	34092	42615
4.20	1039	2079	4157	8314	16628	24942	33256	41570
4.25	1014	2028	4056	8113	16225	24338	32451	40563
4.30	990	1980	3959	7919	15837	23756	31674	39593
4.35	966	1933	3866	7731	15463	23194	30926	38657
4.40	944	1888	3776	7551	15102	22653	30204	37755
4.45	922	1844	3688	7377	14754	22131	29507	36884
4.50	901	1802	3604	7209	14417	21626	28835	36043
4.55	881	1762	3523	7046	14093	21139	28185	35231
4.60	861	1722	3445	6889	13779	20668	27557	34447
4.65	842	1684	3369	6738	13475	20213	26951	33688
4.70	824	1648	3295	6591	13182	19773	26364	32955
4.75	806	1612	3225	6449	12898	19347	25796	32245
4.80	789	1578	3156	6312	12624	18935	25247	31559
4.85	772	1545	3089	6179	12358	18536	24715	30894
4.90	756	1513	3025	6050	12100	18150	24200	30250
4.95	741	1481	2963	5925	11851	17776	23701	29627
5.00	726	1451	2902	5804	11609	17413	23218	29022
5.05	711	1422	2844	5687	11374	17062	22749	28436
5.10	697	1393	2787	5574	11147	16721	22294	27868
5.15	683	1366	2732	5463	10927	16390	21853	27317
5.20	670	1339	2678	5356	10713	16069	21425	26782
5.25	657	1313	2626	5252	10505	15757	21010	26262
5.30	644	1288	2576	5152	10303	15455	20607	25758
5.35	632	1263	2527	5054	10107	15161	20215	25268
5.40	620	1240	2479	4959	9917	14876	19834	24793
5.45	608	1217	2433	4866	9732	14598	19464	24330
5.50	597	1194	2388	4776	9552	14329	19105	23881
5.55	586	1172	2344	4689	9378	14066	18755	23444
5.60	575	1151	2302	4604	9207	13811	18415	23019
5.65	565	1130	2261	4521	9042	13563	18084	22605
5.70	555	1110	2220	4441	8881	13322	17762	22203
5.75	545	1091	2181	4362	8724	13087	17449	21811
5.80	536	1071	2143	4286	8572	12858	17144	21430
5.85	526	1053	2106	4212	8423	12635	16847	21058
5.90	517	1035	2070	4139	8279	12418	16557	20697
5.95	509	1017	2034	4069	8138	12206	16275	20344
6.00	500	1000	2000	4000	8000	12000	16000	20001
6.05	492	983	1967	3933	7866	11799	15733	19666
6.10	483	967	1934	3868	7736	11604	15471	19339
6.15	476	951	1902	3804	7608	11413	15217	19021
6.20	468	936	1871	3742	7484	11226	14968	18710
6.25	460	920	1841	3682	7363	11045	14726	18408
6.30	453	906	1811	3622	7245	10867	14490	18112
6.35	446	891	1782	3565	7129	10694	14259	17823
6.40	439	877	1754	3508	7017	10525	14034	17542
6.45	432	863	1727	3453	6907	10360	13814	17267
6.50	425	850	1700	3400	6799	10199	13599	16998
6.55	418	837	1674	3347	6694	10042	13389	16736
6.60	412	824	1648	3296	6592	9888	13184	16480
6.65	406	811	1623	3246	6492	9738	12984	16230
6.70	400	799	1598	3197	6394	9591	12788	15985
6.75	394	787	1575	3149	6298	9447	12597	15746



x/lr \ tr	0.5	1	2	4	8	12	16	20
6.80	388	776	1551	3102	6205	9307	12410	15512
6.85	382	764	1528	3057	6113	9170	12227	15283
6.90	376	753	1506	3012	6024	9036	12048	15060
6.95	371	742	1484	2968	5936	8905	11873	14841
7.00	366	731	1463	2925	5851	8776	11702	14627
7.05	360	721	1442	2884	5767	8651	11534	14418
7.10	355	711	1421	2843	5685	8528	11371	14213
7.15	350	701	1401	2803	5605	8408	11210	14013
7.20	345	691	1382	2763	5527	8290	11053	13816
7.25	341	681	1362	2725	5450	8175	10899	13624
7.30	336	672	1344	2687	5374	8062	10749	13436
7.35	331	663	1325	2650	5301	7951	10601	13252
7.40	327	654	1307	2614	5229	7843	10457	13071
7.45	322	645	1289	2579	5158	7737	10316	12895
7.50	318	636	1272	2544	5089	7633	10177	12721
7.55	314	628	1255	2510	5021	7531	10041	12552
7.60	310	619	1239	2477	4954	7431	9908	12385
7.65	306	611	1222	2444	4889	7333	9778	12222
7.70	302	603	1206	2412	4825	7237	9650	12062
7.75	298	595	1191	2381	4762	7143	9524	11906
7.80	294	588	1175	2350	4701	7051	9401	11752
7.85	290	580	1160	2320	4640	6961	9281	11601
7.90	286	573	1145	2291	4581	6872	9163	11453
7.95	283	565	1131	2262	4523	6785	9047	11308
8.00	279	558	1117	2233	4466	6700	8933	11166
8.05	276	551	1103	2205	4411	6616	8821	11026
8.10	272	544	1089	2178	4356	6534	8712	10889
8.15	269	538	1076	2151	4302	6453	8604	10755
8.20	266	531	1062	2125	4249	6374	8498	10623
8.25	262	525	1049	2099	4197	6296	8395	10494
8.30	259	518	1037	2073	4147	6220	8293	10366
8.35	256	512	1024	2048	4097	6145	8193	10242
8.40	253	506	1012	2024	4048	6071	8095	10119
8.45	250	500	1000	2000	3999	5999	7999	9998
8.50	247	494	988	1976	3952	5928	7904	9880
8.55	244	488	976	1953	3906	5858	7811	9764
8.60	241	482	965	1930	3860	5790	7720	9650
8.65	238	477	954	1908	3815	5723	7630	9538
8.70	236	471	943	1886	3771	5657	7542	9428
8.75	233	466	932	1864	3728	5592	7455	9319
8.80	230	461	921	1843	3685	5528	7370	9213
8.85	228	455	911	1822	3643	5465	7287	9108
8.90	225	450	901	1801	3602	5403	7204	9005
8.95	223	445	890	1781	3562	5343	7123	8904
9.00	220	440	880	1761	3522	5283	7044	8805
9.05	218	435	871	1741	3483	5224	6966	8707
9.10	215	431	861	1722	3444	5167	6889	8611
9.15	213	426	852	1703	3407	5110	6813	8516
9.20	211	421	842	1685	3369	5054	6739	8423
9.25	208	417	833	1666	3333	4999	6666	8332
9.30	206	412	824	1648	3297	4945	6594	8242
9.35	204	408	815	1631	3261	4892	6523	8153
9.40	202	403	807	1613	3227	4840	6453	8066
9.45	200	399	798	1596	3192	4788	6384	7981
9.50	197	395	790	1579	3159	4738	6317	7896
9.55	195	391	781	1563	3125	4688	6251	7813
9.60	193	387	773	1546	3093	4639	6185	7732

x/lr \ tr	0.5	1	2	4	8	12	16	20
9.65	191	383	765	1530	3060	4591	6121	7651
9.70	189	379	757	1514	3029	4543	6058	7572
9.75	187	375	749	1499	2998	4496	5995	7494
9.80	185	371	742	1483	2967	4450	5934	7417
9.85	184	367	734	1468	2937	4405	5873	7342
9.90	182	363	727	1453	2907	4360	5814	7267
9.95	180	360	719	1439	2878	4316	5755	7194
10.00	178	356	712	1424	2849	4273	5697	7122

### Short time

x/lr \ tsd	0.1	0.2	0.3	0.4
1.40	5102	10204	15306	20408
1.45	4756	9512	14269	19025
1.50	4444	8889	13333	17778
1.55	4162	8325	12487	16649
1.60	3906	7813	11719	15625
1.65	3673	7346	11019	14692
1.70	3460	6920	10381	13841
1.75	3265	6531	9796	13061
1.80	3086	6173	9259	12346
1.85	2922	5844	8766	11687
1.90	2770	5540	8310	11080
1.95	2630	5260	7890	10519
2.00	2500	5000	7500	10000
2.05	2380	4759	7139	9518
2.10	2268	4535	6803	9070
2.15	2163	4327	6490	8653
2.20	2066	4132	6198	8264
2.25	1975	3951	5926	7901
2.30	1890	3781	5671	7561
2.35	1811	3622	5432	7243
2.40	1736	3472	5208	6944
2.45	1666	3332	4998	6664
2.50	1600	3200	4800	6400
2.55	1538	3076	4614	6151
2.60	1479	2959	4438	5917
2.65	1424	2848	4272	5696
2.70	1372	2743	4115	5487
2.75	1322	2645	3967	5289
2.80	1276	2551	3827	5102
2.85	1231	2462	3693	4925
2.90	1189	2378	3567	4756
2.95	1149	2298	3447	4596
3.00	1111	2222	3333	4444
3.05	1075	2150	3225	4300
3.10	1041	2081	3122	4162
3.15	1008	2016	3023	4031
3.20	977	1953	2930	3906
3.25	947	1893	2840	3787
3.30	918	1837	2755	3673
3.35	891	1782	2673	3564

x/lr \ tsd	0.1	0.2	0.3	0.4
3.40	865	1730	2595	3460
3.45	840	1680	2520	3361
3.50	816	1633	2449	3265
3.55	793	1587	2380	3174
3.60	772	1543	2315	3086
3.65	751	1501	2252	3002
3.70	730	1461	2191	2922
3.75	711	1422	2133	2844
3.80	693	1385	2078	2770
3.85	675	1349	2024	2699
3.90	657	1315	1972	2630
3.95	641	1282	1923	2564
4.00	625	1250	1875	2500
4.05	610	1219	1829	2439
4.10	595	1190	1785	2380
4.15	581	1161	1742	2323
4.20	567	1134	1701	2268
4.25	554	1107	1661	2215
4.30	541	1082	1622	2163
4.35	528	1057	1585	2114
4.40	517	1033	1550	2066
4.45	505	1010	1515	2020
4.50	494	988	1481	1975
4.55	483	966	1449	1932
4.60	473	945	1418	1890
4.65	462	925	1387	1850
4.70	453	905	1358	1811
4.75	443	886	1330	1773
4.80	434	868	1302	1736
4.85	425	850	1275	1700
4.90	416	833	1249	1666
4.95	408	816	1224	1632
5.00	400	800	1200	1600
5.05	392	784	1176	1568
5.10	384	769	1153	1538
5.15	377	754	1131	1508
5.20	370	740	1109	1479
5.25	363	726	1088	1451
5.30	356	712	1068	1424
5.35	349	699	1048	1398

# Time chart

Susol

## Short time

$\frac{tsd}{xIr}$	0.1	0.2	0.3	0.4
5.40	343	686	1029	1372
5.45	337	673	1010	1347
5.50	331	661	992	1322
5.55	325	649	974	1299
5.60	319	638	957	1276
5.65	313	627	940	1253
5.70	308	616	923	1231
5.75	302	605	907	1210
5.80	297	595	892	1189
5.85	292	584	877	1169
5.90	287	575	862	1149
5.95	282	565	847	1130
6.00	278	556	833	1111
6.05	273	546	820	1093
6.10	269	537	806	1075
6.15	264	529	793	1058
6.20	260	520	780	1041
6.25	256	512	768	1024
6.30	252	504	756	1008
6.35	248	496	744	992
6.40	244	488	732	977
6.45	240	481	721	961
6.50	237	473	710	947
6.55	233	466	699	932
6.60	230	459	689	918
6.65	226	452	678	905
6.70	223	446	668	891
6.75	219	439	658	878
6.80	216	433	649	865
6.85	213	426	639	852
6.90	210	420	630	840
6.95	207	414	621	828
7.00	204	408	612	816
7.05	201	402	604	805
7.10	198	397	595	793
7.15	196	391	587	782
7.20	193	386	579	772
7.25	190	380	571	761
7.30	188	375	563	751
7.35	185	370	555	740
7.40	183	365	548	730
7.45	180	360	541	721
7.50	178	356	533	711
7.55	175	351	526	702
7.60	173	346	519	693
7.65	171	342	513	683
7.70	169	337	506	675
7.75	166	333	499	666
7.80	164	329	493	657
7.85	162	325	487	649
7.90	160	320	481	641
7.95	158	316	475	633
8.00	156	312	469	625
8.05	154	309	463	617
8.10	152	305	457	610
8.15	151	301	452	602
8.20	149	297	446	595

$\frac{tsd}{xIr}$	0.1	0.2	0.3	0.4
8.25	147	294	441	588
8.30	145	290	435	581
8.35	143	287	430	574
8.40	142	283	425	567
8.45	140	280	420	560
8.50	138	277	415	554
8.55	137	274	410	547
8.60	135	270	406	541
8.65	134	267	401	535
8.70	132	264	396	528
8.75	131	261	392	522
8.80	129	258	387	517
8.85	128	255	383	511
8.90	126	252	379	505
8.95	125	250	375	499
9.00	123	247	370	494
9.05	122	244	366	488
9.10	121	242	362	483
9.15	119	239	358	478
9.20	118	236	354	473
9.25	117	234	351	467
9.30	116	231	347	462
9.35	114	229	343	458
9.40	113	226	340	453
9.45	112	224	336	448
9.50	111	222	332	443
9.55	110	219	329	439
9.60	109	217	326	434
9.65	107	215	322	430
9.70	106	213	319	425
9.75	105	210	316	421
9.80	104	208	312	416
9.85	103	206	309	412
9.90	102	204	306	408
9.95	101	202	303	404
10.00	100	200	300	400

## Ground fault

$\frac{tg}{xIn}$	0.1	0.2	0.3	0.4
0.20	2500	5000	7500	10000
0.21	2268	4535	6803	9070
0.22	2066	4132	6198	8264
0.23	1890	3781	5671	7561
0.24	1736	3472	5208	6944
0.25	1600	3200	4800	6400
0.26	1479	2959	4438	5917
0.27	1372	2743	4115	5487
0.28	1276	2551	3827	5102
0.29	1189	2378	3567	4756
0.30	1111	2222	3333	4444
0.31	1041	2081	3122	4162
0.32	977	1953	2930	3906
0.33	918	1837	2755	3673
0.34	865	1730	2595	3460
0.35	816	1633	2449	3265
0.36	772	1543	2315	3086
0.37	730	1461	2191	2922
0.38	693	1385	2078	2770
0.39	657	1315	1972	2630
0.40	625	1250	1875	2500
0.41	595	1190	1785	2380
0.42	567	1134	1701	2268
0.43	541	1082	1622	2163
0.44	517	1033	1550	2066
0.45	494	988	1481	1975
0.46	473	945	1418	1890
0.47	453	905	1358	1811
0.48	434	868	1302	1736
0.49	416	833	1249	1666
0.50	400	800	1200	1600
0.51	384	769	1153	1538
0.52	370	740	1109	1479
0.53	356	712	1068	1424
0.54	343	686	1029	1372
0.55	331	661	992	1322
0.56	319	638	957	1276
0.57	308	616	923	1231
0.58	297	595	892	1189
0.59	287	575	862	1149
0.60	278	556	833	1111
0.61	269	537	806	1075
0.62	260	520	780	1041
0.63	252	504	756	1008
0.64	244	488	732	977
0.65	237	473	710	947
0.66	230	459	689	918
0.67	223	446	668	891
0.68	216	433	649	865
0.69	210	420	630	840
0.70	204	408	612	816
0.71	198	397	595	793
0.72	193	386	579	772
0.73	188	375	563	751
0.74	183	365	548	730
0.75	178	356	533	711
0.76	173	346	519	693

$\frac{tg}{xIn}$	0.1	0.2	0.3	0.4
0.77	169	337	506	675
0.78	164	329	493	657
0.79	160	320	481	641
0.80	156	313	469	625
0.81	152	305	457	610
0.82	149	297	446	595
0.83	145	290	435	581
0.84	142	283	425	567
0.85	138	277	415	554
0.86	135	270	406	541
0.87	132	264	396	528
0.88	129	258	387	517
0.89	126	252	379	505
0.90	123	247	370	494
0.91	121	242	362	483
0.92	118	236	354	473
0.93	116	231	347	462
0.94	113	226	340	453
0.95	111	222	332	443
0.96	109	217	326	434
0.97	106	213	319	425
0.98	104	208	312	416
0.99	102	204	306	408
1.00	100	200	300	400

# Ordering sheet

For faster quote processing, please use the following request for ordering sheet. For each section, check the applicable box or enter value corresponding to your choice.

Receipt	LS Industrial System co., Ltd	Order date		Distributor name
Project		Contractor		
Delivery place		Delivery date		PNL Maker

ACB main body	Type of ACB	AH AN Note 1) AS		Quantity																																																																																																																																																																																																																																																																																																													
	Frame size	D (630-2000AF) Note 1) E (2000-4000AF)		F (4000-5000AF) G (4000-6300AF)																																																																																																																																																																																																																																																																																																													
	Ratings	AF																																																																																																																																																																																																																																																																																																															
	Rated current (CT)	A																																																																																																																																																																																																																																																																																																															
	Trip relay	NO YES																																																																																																																																																																																																																																																																																																															
		<table border="1"> <thead> <tr> <th rowspan="2">Type</th> <th colspan="2">Frequency</th> <th colspan="2">Control voltage</th> <th colspan="2">Comm.</th> <th colspan="2">Optional function</th> <th rowspan="2">Type</th> <th colspan="2">Frequency</th> <th colspan="2">Control voltage</th> <th colspan="2">Comm.</th> <th colspan="2">Optional function</th> </tr> <tr> <th>60Hz</th> <th>50Hz</th> <th>No</th> <th>AC/DC 110-220V</th> <th>DC 24-48V</th> <th>No</th> <th>Yes</th> <th>Earth leakage detection</th> <th>External CT ground fault</th> <th>50Hz</th> <th>60Hz</th> <th>AC/DC 110-220V</th> <th>DC 24-48V</th> <th>Comm.</th> <th>Earth leakage detection</th> <th>External CT ground fault</th> <th>Pre-Trip Alarm</th> </tr> </thead> <tbody> <tr> <td rowspan="10">N Normal</td> <td>NGO</td> <td>NG5</td> <td>-</td> <td>-</td> <td>-</td> <td>-</td> <td>-</td> <td>-</td> <td rowspan="10">P Power meter</td> <td>PC1</td> <td>PC6</td> <td>-</td> <td>-</td> <td>-</td> <td>-</td> <td>-</td> <td>-</td> </tr> <tr> <td>AGO</td> <td>AG5</td> <td>-</td> <td>-</td> <td>-</td> <td>-</td> <td>-</td> <td>PC2</td> <td>PC7</td> <td>-</td> <td>-</td> <td>-</td> <td>-</td> <td>-</td> <td>-</td> <td>-</td> </tr> <tr> <td>AG1</td> <td>AG6</td> <td>-</td> <td>-</td> <td>-</td> <td>-</td> <td>-</td> <td>PK1</td> <td>PK6</td> <td>-</td> <td>-</td> <td>-</td> <td>-</td> <td>-</td> <td>-</td> <td>-</td> </tr> <tr> <td>AG2</td> <td>AG7</td> <td>-</td> <td>-</td> <td>-</td> <td>-</td> <td>-</td> <td>PK2</td> <td>PK7</td> <td>-</td> <td>-</td> <td>-</td> <td>-</td> <td>-</td> <td>-</td> <td>-</td> </tr> <tr> <td>AZ0</td> <td>AZ5</td> <td>-</td> <td>-</td> <td>-</td> <td>-</td> <td>-</td> <td>PX1</td> <td>PX6</td> <td>-</td> <td>-</td> <td>-</td> <td>-</td> <td>-</td> <td>-</td> <td>-</td> </tr> <tr> <td>AZ1</td> <td>AZ6</td> <td>-</td> <td>-</td> <td>-</td> <td>-</td> <td>-</td> <td>PX2</td> <td>PX7</td> <td>-</td> <td>-</td> <td>-</td> <td>-</td> <td>-</td> <td>-</td> <td>-</td> </tr> <tr> <td>AZ2</td> <td>AZ7</td> <td>-</td> <td>-</td> <td>-</td> <td>-</td> <td>-</td> <td>PA1</td> <td>PA6</td> <td>-</td> <td>-</td> <td>-</td> <td>-</td> <td>-</td> <td>-</td> <td>-</td> </tr> <tr> <td>AE0</td> <td>AE5</td> <td>-</td> <td>-</td> <td>-</td> <td>-</td> <td>-</td> <td>PA2</td> <td>PA7</td> <td>-</td> <td>-</td> <td>-</td> <td>-</td> <td>-</td> <td>-</td> <td>-</td> </tr> <tr> <td rowspan="10">A Ammeter</td> <td>AE1</td> <td>AE6</td> <td>-</td> <td>-</td> <td>-</td> <td>-</td> <td>-</td> <td>SC1</td> <td>SC6</td> <td>-</td> <td>-</td> <td>-</td> <td>-</td> <td>-</td> <td>-</td> <td>-</td> </tr> <tr> <td>AE2</td> <td>AE7</td> <td>-</td> <td>-</td> <td>-</td> <td>-</td> <td>-</td> <td>SC2</td> <td>SC7</td> <td>-</td> <td>-</td> <td>-</td> <td>-</td> <td>-</td> <td>-</td> <td>-</td> </tr> <tr> <td>AC1</td> <td>AC6</td> <td>-</td> <td>-</td> <td>-</td> <td>-</td> <td>-</td> <td>SK1</td> <td>SK6</td> <td>-</td> <td>-</td> <td>-</td> <td>-</td> <td>-</td> <td>-</td> <td>-</td> </tr> <tr> <td>AC2</td> <td>AC7</td> <td>-</td> <td>-</td> <td>-</td> <td>-</td> <td>-</td> <td>SK2</td> <td>SK7</td> <td>-</td> <td>-</td> <td>-</td> <td>-</td> <td>-</td> <td>-</td> <td>-</td> </tr> <tr> <td>AK1</td> <td>AK6</td> <td>-</td> <td>-</td> <td>-</td> <td>-</td> <td>-</td> <td>SX1</td> <td>SX6</td> <td>-</td> <td>-</td> <td>-</td> <td>-</td> <td>-</td> <td>-</td> <td>-</td> </tr> <tr> <td>AK2</td> <td>AK7</td> <td>-</td> <td>-</td> <td>-</td> <td>-</td> <td>-</td> <td>SX2</td> <td>SX7</td> <td>-</td> <td>-</td> <td>-</td> <td>-</td> <td>-</td> <td>-</td> <td>-</td> </tr> <tr> <td>AX1</td> <td>AX6</td> <td>-</td> <td>-</td> <td>-</td> <td>-</td> <td>-</td> <td>SA1</td> <td>SA6</td> <td>-</td> <td>-</td> <td>-</td> <td>-</td> <td>-</td> <td>-</td> <td>-</td> </tr> <tr> <td>AX2</td> <td>AX7</td> <td>-</td> <td>-</td> <td>-</td> <td>-</td> <td>-</td> <td>SA2</td> <td>SA7</td> <td>-</td> <td>-</td> <td>-</td> <td>-</td> <td>-</td> <td>-</td> <td>-</td> </tr> </tbody> </table>										Type	Frequency		Control voltage		Comm.		Optional function		Type	Frequency		Control voltage		Comm.		Optional function		60Hz	50Hz	No	AC/DC 110-220V	DC 24-48V	No	Yes	Earth leakage detection	External CT ground fault	50Hz	60Hz	AC/DC 110-220V	DC 24-48V	Comm.	Earth leakage detection	External CT ground fault	Pre-Trip Alarm	N Normal	NGO	NG5	-	-	-	-	-	-	P Power meter	PC1	PC6	-	-	-	-	-	-	AGO	AG5	-	-	-	-	-	PC2	PC7	-	-	-	-	-	-	-	AG1	AG6	-	-	-	-	-	PK1	PK6	-	-	-	-	-	-	-	AG2	AG7	-	-	-	-	-	PK2	PK7	-	-	-	-	-	-	-	AZ0	AZ5	-	-	-	-	-	PX1	PX6	-	-	-	-	-	-	-	AZ1	AZ6	-	-	-	-	-	PX2	PX7	-	-	-	-	-	-	-	AZ2	AZ7	-	-	-	-	-	PA1	PA6	-	-	-	-	-	-	-	AE0	AE5	-	-	-	-	-	PA2	PA7	-	-	-	-	-	-	-	A Ammeter	AE1	AE6	-	-	-	-	-	SC1	SC6	-	-	-	-	-	-	-	AE2	AE7	-	-	-	-	-	SC2	SC7	-	-	-	-	-	-	-	AC1	AC6	-	-	-	-	-	SK1	SK6	-	-	-	-	-	-	-	AC2	AC7	-	-	-	-	-	SK2	SK7	-	-	-	-	-	-	-	AK1	AK6	-	-	-	-	-	SX1	SX6	-	-	-	-	-	-	-	AK2	AK7	-	-	-	-	-	SX2	SX7	-	-	-	-	-	-	-	AX1	AX6	-	-	-	-	-	SA1	SA6	-	-	-	-	-	-	-	AX2	AX7	-	-	-	-	-	SA2	SA7	-	-	-	-	-	-	-
	Type	Frequency		Control voltage		Comm.		Optional function		Type	Frequency		Control voltage		Comm.		Optional function																																																																																																																																																																																																																																																																																																
		60Hz	50Hz	No	AC/DC 110-220V	DC 24-48V	No	Yes	Earth leakage detection		External CT ground fault	50Hz	60Hz	AC/DC 110-220V	DC 24-48V	Comm.	Earth leakage detection	External CT ground fault	Pre-Trip Alarm																																																																																																																																																																																																																																																																																														
	N Normal	NGO	NG5	-	-	-	-	-	-	P Power meter	PC1	PC6	-	-	-	-	-	-																																																																																																																																																																																																																																																																																															
		AGO	AG5	-	-	-	-	-	PC2		PC7	-	-	-	-	-	-	-																																																																																																																																																																																																																																																																																															
AG1		AG6	-	-	-	-	-	PK1	PK6		-	-	-	-	-	-	-																																																																																																																																																																																																																																																																																																
AG2		AG7	-	-	-	-	-	PK2	PK7		-	-	-	-	-	-	-																																																																																																																																																																																																																																																																																																
AZ0		AZ5	-	-	-	-	-	PX1	PX6		-	-	-	-	-	-	-																																																																																																																																																																																																																																																																																																
AZ1		AZ6	-	-	-	-	-	PX2	PX7		-	-	-	-	-	-	-																																																																																																																																																																																																																																																																																																
AZ2		AZ7	-	-	-	-	-	PA1	PA6		-	-	-	-	-	-	-																																																																																																																																																																																																																																																																																																
AE0		AE5	-	-	-	-	-	PA2	PA7		-	-	-	-	-	-	-																																																																																																																																																																																																																																																																																																
A Ammeter		AE1	AE6	-	-	-	-	-	SC1		SC6	-	-	-	-	-	-	-																																																																																																																																																																																																																																																																																															
		AE2	AE7	-	-	-	-	-	SC2		SC7	-	-	-	-	-	-	-																																																																																																																																																																																																																																																																																															
	AC1	AC6	-	-	-	-	-	SK1	SK6	-	-	-	-	-	-	-																																																																																																																																																																																																																																																																																																	
	AC2	AC7	-	-	-	-	-	SK2	SK7	-	-	-	-	-	-	-																																																																																																																																																																																																																																																																																																	
	AK1	AK6	-	-	-	-	-	SX1	SX6	-	-	-	-	-	-	-																																																																																																																																																																																																																																																																																																	
	AK2	AK7	-	-	-	-	-	SX2	SX7	-	-	-	-	-	-	-																																																																																																																																																																																																																																																																																																	
	AX1	AX6	-	-	-	-	-	SA1	SA6	-	-	-	-	-	-	-																																																																																																																																																																																																																																																																																																	
	AX2	AX7	-	-	-	-	-	SA2	SA7	-	-	-	-	-	-	-																																																																																																																																																																																																																																																																																																	
	No. of poles	3-pole			4-pole		Standard type (R, S, T, N) Reverse phase type (N, R, S, T)																																																																																																																																																																																																																																																																																																										
	Installation type	Draw-out type			Fixed type																																																																																																																																																																																																																																																																																																												
Closing type	Manual closing			Electrical closing																																																																																																																																																																																																																																																																																																													
	<ul style="list-style-type: none"> <li>Charge method: Charging completion contact(1b) is basically installed</li> <li>Motor operating voltage</li> </ul>			Standard type (OFF-Charge method) Rapid auto-reclosing type (ON-Charge method)																																																																																																																																																																																																																																																																																																													
Closing voltage	AC/DC 100V-130V		AC/DC 200V-250V	DC 125V	DC 24V-30V	DC 48V-60V	AC 440V-480V	AC 48V																																																																																																																																																																																																																																																																																																									
Trip voltage	AC/DC 100V-130V		AC/DC 200V-250V	DC 125V	DC 24V-30V	DC 48V-60V	AC 380V-480V	AC 48V																																																																																																																																																																																																																																																																																																									
ACB cradle	Cradle type	No safety shutter (E class)			Safety shutter attachment (F class)																																																																																																																																																																																																																																																																																																												
	Terminal connection	Manual connection			Automatic connection																																																																																																																																																																																																																																																																																																												
	Connections	Horizontal		Vertical		Front connection																																																																																																																																																																																																																																																																																																											
		Line: Horizontal, Load: Vertical		Line: Vertical, Load: Horizontal		Separate order/ User Installation																																																																																																																																																																																																																																																																																																											
ACB accessory	ACB Main body	Standard accessory	• Aux. contact(AX)		Standard type (3a3b, Standard installation)		Extended type (5a5b) Note 4)		High capacity (5a5b) Note 3)																																																																																																																																																																																																																																																																																																								
			• Key Lock(K1, K3)				Single key, K1 (ON - Lock)		Double key, K3 (ON - Lock)																																																																																																																																																																																																																																																																																																								
			• Undervoltage trip device (UVT, Instantaneous)																																																																																																																																																																																																																																																																																																														
			AC/DC 100V-130V		AC/DC 200V-250V		DC 125V		DC 24V-30V		DC 48V-60V																																																																																																																																																																																																																																																																																																						
			• Mechanical operation contact (MOC), Door Interlock (DI)						Non-attachment type		Attachment type																																																																																																																																																																																																																																																																																																						
			• Mechanical interlock (MI)						Non-attachment type		Attachment type																																																																																																																																																																																																																																																																																																						
			• Counter(C) Note 2)						Non-attachment type		Attachment type																																																																																																																																																																																																																																																																																																						
			• Miss insertion preventive device (MIP)						Non-attachment type		Attachment type																																																																																																																																																																																																																																																																																																						
			• Automatically discharge mechanism(ADM)						Non-attachment type		Attachment type																																																																																																																																																																																																																																																																																																						
			• Double shunt coil(SHT2)						Non-attachment type		Attachment type																																																																																																																																																																																																																																																																																																						
• Ready-to-close switch(RCS)						Non-attachment type		Attachment type																																																																																																																																																																																																																																																																																																									
• Trip alarm switch, Manual reset button(AL, MRB)						Non-attachment type		Attachment type																																																																																																																																																																																																																																																																																																									
Key interlock (K2, ON - Lock)						ON/OFF Button Lock		Temperature Alarm																																																																																																																																																																																																																																																																																																									
ACB Cradle	Standard accessory	Safety shutter lock(STL)																																																																																																																																																																																																																																																																																																															
		Zero arc space(ZAS) Note 2)																																																																																																																																																																																																																																																																																																															
Separate purchase	Main body mounting	Insulation barrier(IB)																																																																																																																																																																																																																																																																																																															
		Slow closing lever(SL)																																																																																																																																																																																																																																																																																																															
	Cradle mounting	• Cell switch(CL)		4c		8c																																																																																																																																																																																																																																																																																																											
		Door interlock(DI)																																																																																																																																																																																																																																																																																																															
		• Mechanical operation contact (MOC)						Standard type (10a10b)		High capacity(10a10b)																																																																																																																																																																																																																																																																																																							
		• Mechanical Interlock (MI)						Wire type (2 terminals)		Wire type (3 terminals)																																																																																																																																																																																																																																																																																																							
		• Shortening b-contact (SBC, 4b Max)				1b		2b		3b																																																																																																																																																																																																																																																																																																							
		• Miss insertion preventive device (MIP)						Non-attachment type		Attachment type																																																																																																																																																																																																																																																																																																							
	External mounting	Cradle mounting block(CMB)		Safety control cover(SC)																																																																																																																																																																																																																																																																																																													
		Racking interlock(RI)		Insulation barrier(IB) Note 2)																																																																																																																																																																																																																																																																																																													
		• UVT time delay controller(UDC)																																																																																																																																																																																																																																																																																																															
		AC/DC 100V-130V		AC/DC 200V-250V		DC 125V		DC 48V-60V		AC 380V-480V																																																																																																																																																																																																																																																																																																							
	Door frame (DF)		Condenser trip device (CTD)				OCR tester																																																																																																																																																																																																																																																																																																										
	Dust cover(DC)		Profibus-DP Comm.(PC)				Temperature alarm(TM)		Remote I/O(RCO)																																																																																																																																																																																																																																																																																																								

Note) 1. In case of D type of Metasol (AN), frame size is in the range of 630-1600AF  
 2. The standard accessory for Susol (AH).  
 3. Aux. contact with extended/high capacity type adopts the rapid auto-reclosing method and available up to 6a6b.

Super Solution

*Leader in Electrics & Automation*

■ **HEAD OFFICE**

Yonsei Jaedan Severance Bldg. 84-11, 5ga, Namdaemun-ro,  
Jung-gu, Seoul 100-753, Korea  
Tel. (82-2)2034-4870 Fax. (82-2)2034-4713 <http://www.lsis.biz>

■ **Cheong-Ju Plant**

Cheong-Ju Plant #1, Song Jung Dong, Hung Duk Ku,  
Cheong Ju, 361-720, Korea  
Tel. (82-43)261-6001 Fax. (82-43)261-6410

Specifications in this catalog are subject to change without notice due to  
continuous products development and improvement.

**LS Industrial Systems Co., Ltd.**

071005 / STAFF  
© 2006.2 LS Industrial Systems Co.,Ltd. All rights reserved.